

Occhio

owner's manual

your  
luminaire

Gioia equilibrio

Thank  
you

Vielen Dank, dass Sie sich für eine Leuchte von Occhio entschieden haben. Wir wünschen Ihnen viel Freude damit. Genießen Sie die neue Kultur des Lichts von Occhio!

Thank you for choosing a luminaire from Occhio. We hope it brings you plenty of joy. Enjoy the new culture of light from Occhio!

Nous vous remercions d'avoir choisi un luminaire Occhio et espérons que vous apprécierez votre produit. Profitez de la nouvelle culture de la lumière d'Occhio !

Gracias por elegir una lámpara de Occhio. Esperamos que disfrutes de ella. ¡Vive la cultura de la luz de Occhio!

Grazie per aver scelto una lampada Occhio e ci auguriamo che tu sia soddisfatto. Goditi la nuova cultura della luce di Occhio!

To those who strive for  
new horizons.



# Gioia equilibrio

Helligkeit, wo immer Sie sie sich wünschen. Licht genau so, wie Sie es gerade benötigen. Gioia equilibrio fasziniert mit unendlicher Beweglichkeit und dem Gefühl von Schwerelosigkeit. Und einer nahezu skulpturalen Erscheinung, die sich immer wieder verändert.

Brightness wherever you want it. Light exactly how you need it. Gioia equilibrio fascinates with infinite mobility and the feeling of weightlessness. And an almost sculptural appearance that keeps changing.

La luminosité où vous le souhaitez. L'éclairage selon vos besoins. Gioia equilibrio fascine par son infinie mobilité et sa sensation d'apesanteur. Et par un aspect presque sculptural en métamorphose constante.

Luminosidad donde quieras. Ilumina exactamente como lo necesitas. Gioia equilibrio fascina con una movilidad infinita y una sensación de ingravidez mientras su apariencia casi escultórica no para de cambiar.

La luminosità, esattamente dove la desiderate. La luce, precisamente quella di cui avete bisogno. Gioia equilibrio affascina con la sua mobilità infinita e la sensazione dell'assenza di gravità. E con un'estetica quasi scultorea che non rimane mai uguale a se stessa.



# Gioia equilibrio

Steuerung / Control / Contrôle / Controlar / Controllo .....	9
Occhio air .....	15
Montage / Mounting / Assemblée / Montaje / Assemblaggio .....	33







# Gioia equilibrio

Steuerung / Control / Contrôle / Controlar / Controllo

## touchless control

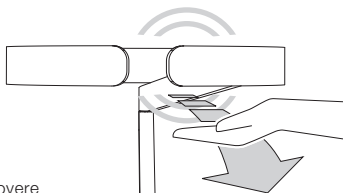
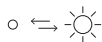

### on / off

bewegen, move, déplacer, mover, muovere

---

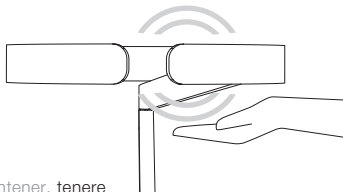
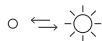

### dim

halten, hold, appuyer longuement, maintenir, tenere

---

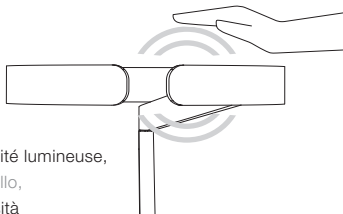

### up / down fading

lange halten → Helligkeit einstellen,

keep holding → Adjust brightness,

appuyer longuement → régler l'intensité lumineuse,

mantener más tiempo → ajustar el brillo,

tenere a lungo → regolazione luminosità

---

2700 K      4000 K

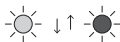

### color tune

halten → Farbtemperatur einstellen,

last long → adjust the color temperature,

tenir → ajuster la température de la couleur,

mantener → ajustar la temperatura de color,

tenere → regolazione della temperatura di colore

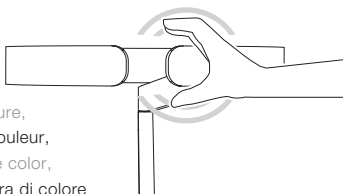

### focus light on / off

bewegen, move, déplacer, mover, muovere

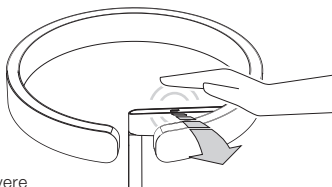

# infinite move

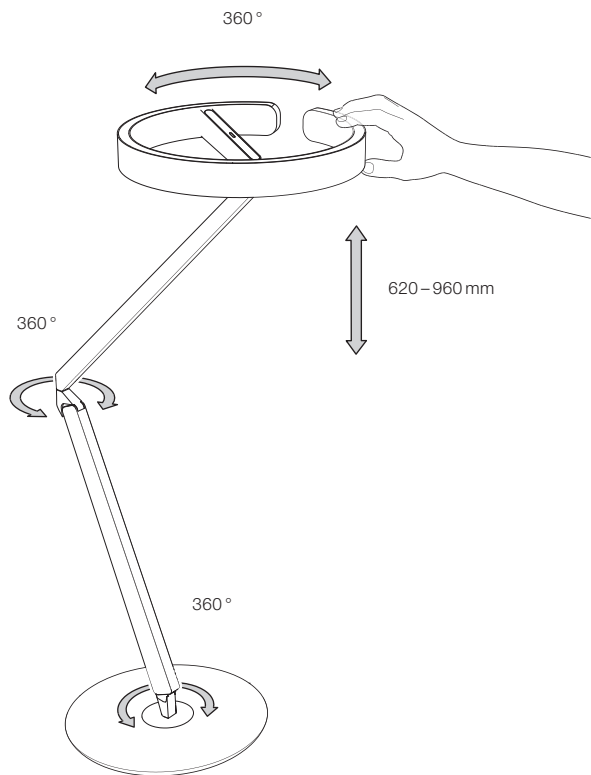





# Occhio air



App installieren und öffnen.

Install and open the app.

Installer et ouvrir l'application.

Instala y abre la aplicación.

Installare e aprire l'applicazione.





Angeschlossene Leuchten einrichten und Netzwerk erstellen.

Set up connected luminaires and create network.

Configurer les luminaires connectés et créer un réseau.

Configurar las luminarias conectadas y crear una red.

Impostare gli apparecchi collegati e creare una rete.

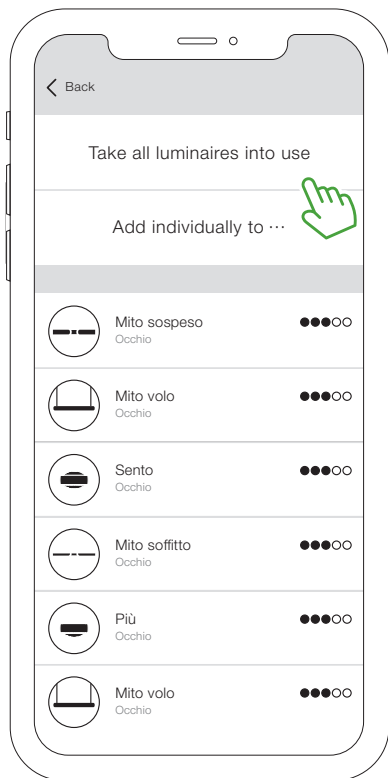

Leuchten steuern.

Control luminaires.

Apparecchi di controllo.

Luminarias de control.

Apparecchi di controllo.

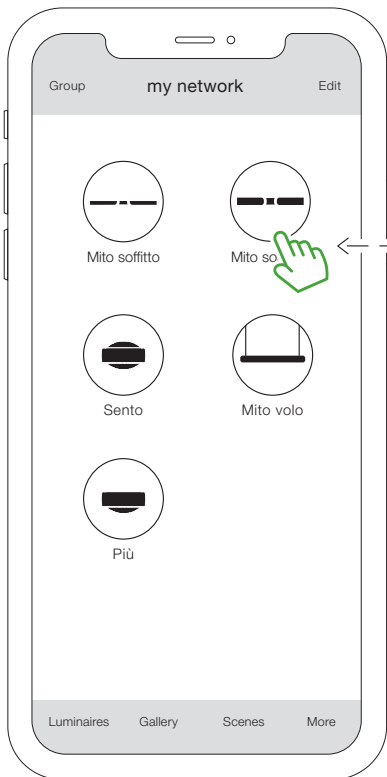

Steuerungsgesten.  
Control gestures.  
Gestes de contrôle.  
Gestes de contrôle.  
Gesti di controllo.

Nur bei Leuchten mit beidseitigem  
Lichtaustritt\*, color tune\*\*  
oder magic move\*\*\*

Only for luminaires with double-  
sided light output\*, color tune\*\*  
or magic move\*\*\*

Uniquement pour les luminaires avec  
rendement lumineux double face\*,  
color tune\*\* ou magic move\*\*\*.

Sólo para luminarias con salida  
de luz de doble cara\*, color tune\*\*  
o magic move\*\*\*

Solo per apparecchi con emissione  
luminosa su entrambi i lati\*,  
color tune\*\* o magic move\*\*\*

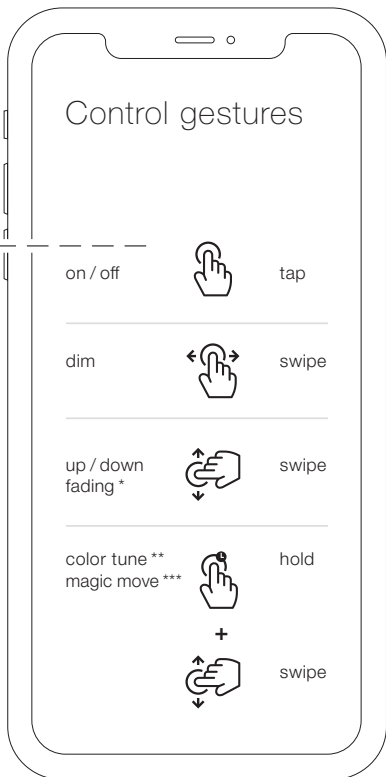

Netzwerk teilen: Optional kann nun das erstellte Netzwerk (my network) mit anderen geteilt werden.

share network: Optionally, the created network (my network) can now be shared with others.

partager le réseau : En option, le réseau créé (mon réseau) peut maintenant être partagé avec d'autres personnes.

compartir red: Opcionalmente, la red creada (mi red) puede ahora ser compartida con otros.

condividi rete: Opzionalmente, la rete creata (la mia rete) può ora essere condivisa con altri.

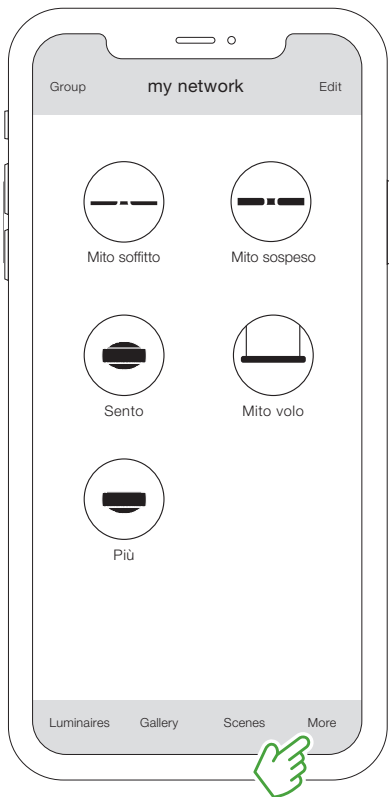

Netzwerknamen vergeben.

Assign network name.

Attribuer un nom de réseau.

Asigna el nombre de la red.

Assegnare il nome della rete.

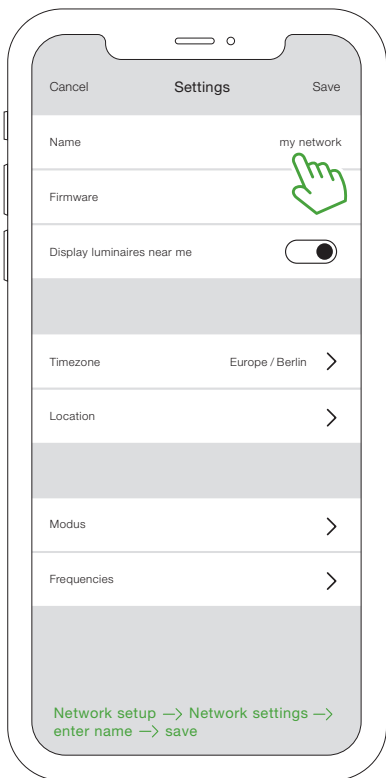

Netzwerk freigeben.  
Share network.  
Partager le réseau.  
Comparte la red.  
Condividere la rete.

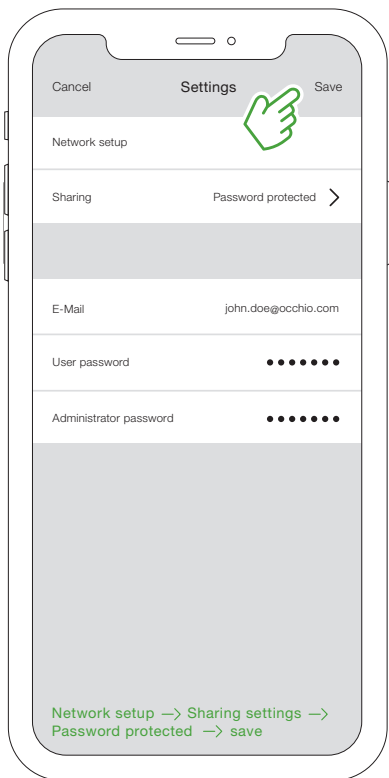



# Occhio air sync

Leuchten im Netzwerk gruppieren und features mittels touchless control gemeinsam steuern.

Group luminaires in a network and control features with touchless control together.

Regroupez les luminaires dans un réseau et contrôlez ensemble les fonctions avec la touchless control.

Agrupe las luminarias en una red y controle las funciones con touchless control de forma conjunta.

Raggruppate gli apparecchi in una rete e controllate insieme le funzioni con il touchless control.

\*Funktionen abhängig vom Leuchtenmodell.

\*Fonctions dépendant du modèle de luminaire.

\*Fonctions dépendant du modèle de luminaire.

\*Las funciones dependen del modelo de luminaria.

\*Le funzioni dipendono dal modello di apparecchio.



Einstellungen der Leuchte öffnen.  
Open settings of the luminaire.  
Ouvrir les réglages du luminaire.  
Abrir los ajustes de la luminaria.  
Aprire le impostazioni dell'apparecchio.

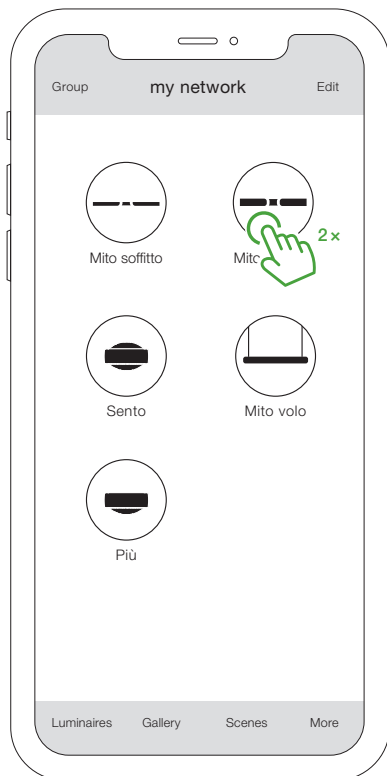

Parameter: Zusatzoptionen der Leuchte aktivieren oder Einstellungen vornehmen (air sync, air sync height, presence sensor, ambient light control)\*

Parameter: Activate additional options of the luminaire or make settings (air sync, air sync height, presence sensor, ambient light control)\*

Paramètre : Activez des options supplémentaires du luminaire ou effectuez des réglages (air sync, air sync height, presence sensor, ambient light control)\*.

Parámetros: Activar opciones adicionales de la luminaria o realizar ajustes (air sync, air sync height, presence sensor, ambient light control)\*.

Parametri: Attivare opzioni aggiuntive dell'apparecchio o effettuare impostazioni (air sync, air sync height, presence sensor, ambient light control)\*.

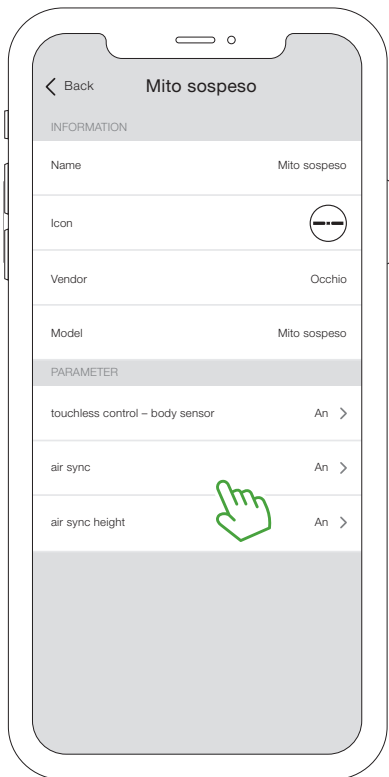

Gruppe erstellen.  
Create a group.  
Créez un groupe.  
Crea un grupo.  
Creare un gruppo.

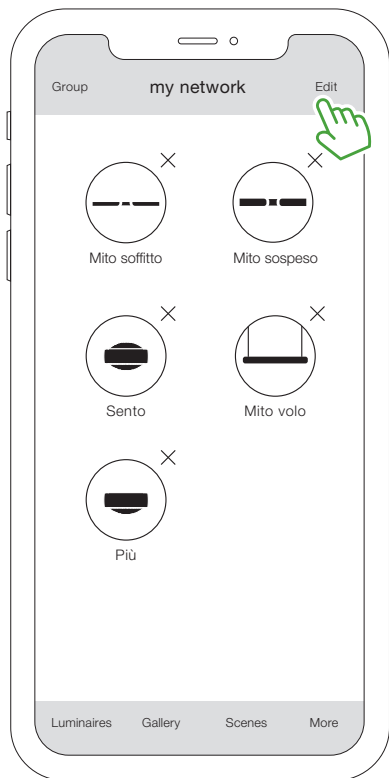

Leuchtsymbole übereinanderlegen.

Superimpose luminaire icons.

Superposer les icônes des luminaires.

Superponer iconos de luminarias.

Superponer iconos de luminarias.

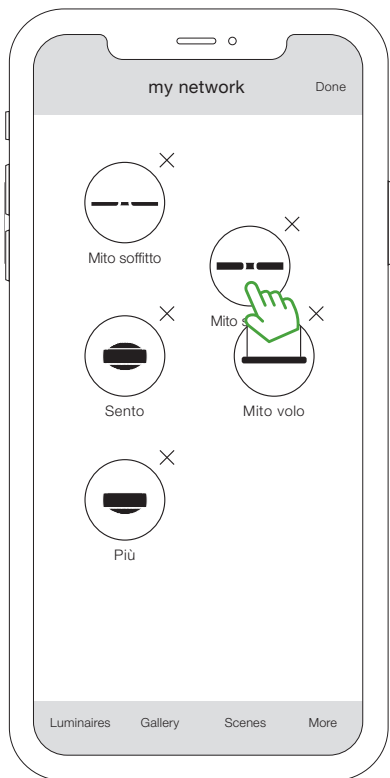

Bearbeiten beenden.

Exit edit.

Montage de sortie.

Edición de salida.

Modifica dell'uscita.

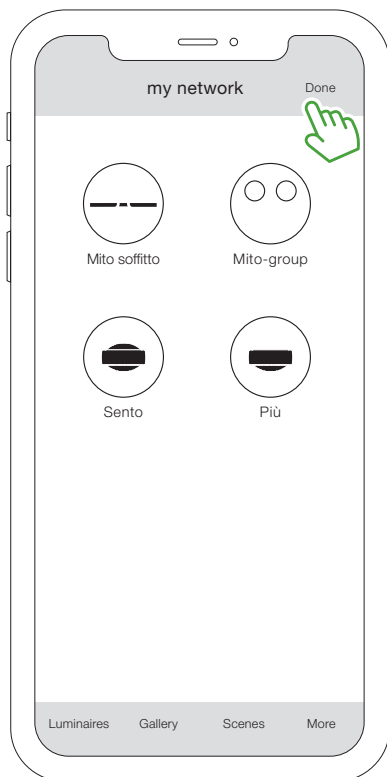

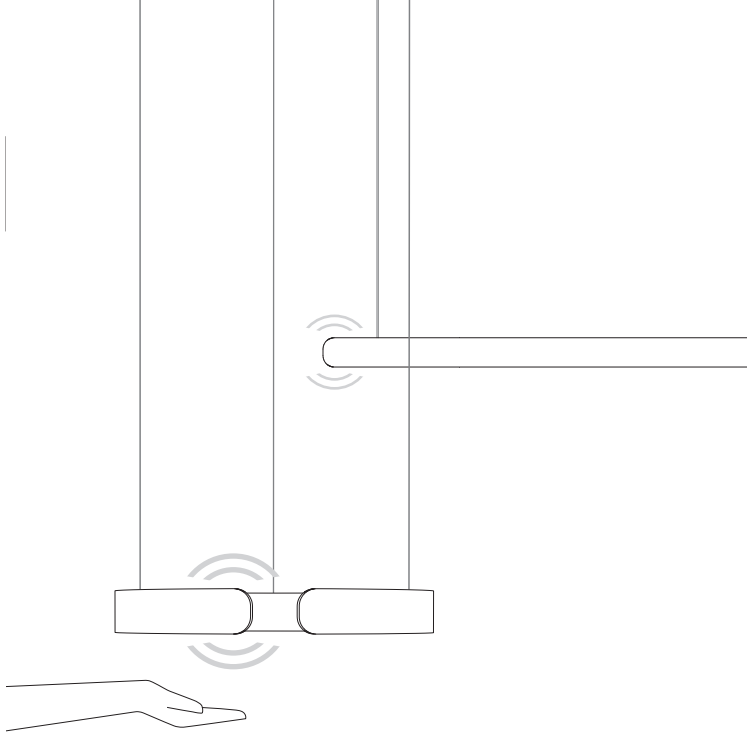



Die synchronisierten Leuchten, innerhalb einer Gruppe, können nun gemeinsam mittels touchless control gesteuert werden.

Weitere Infos unter: [www.occhio.com/faq](http://www.occhio.com/faq)

The synchronized luminaires within a group can now be controlled together with touchless control.

Further info at: [www.occhio.com/faq](http://www.occhio.com/faq)

Les luminaires synchronisés au sein d'un groupe peuvent désormais être contrôlés ensemble grâce à la touchless control.

Plus d'informations : [www.occhio.com/faq](http://www.occhio.com/faq)

Las luminarias sincronizadas dentro de un grupo pueden ahora controlarse conjuntamente con el touchless control.

Más información en: [www.occhio.com/faq](http://www.occhio.com/faq)

Gli apparecchi sincronizzati all'interno di un gruppo possono ora essere controllati insieme con il touchless control.

Ulteriori informazioni su: [www.occhio.com/faq](http://www.occhio.com/faq)





# Gioia equilibrio

Montage / Mounting / Assemblée / Montaje / Assemblaggio

Verpackung der base wie abgebildet öffnen.

Open the base as shown.

Ouvrir l'emballage de la base conformément au schéma.

Abra el embalaje de la base como se indica.

Aprire l'imballaggio della base come illustrato.

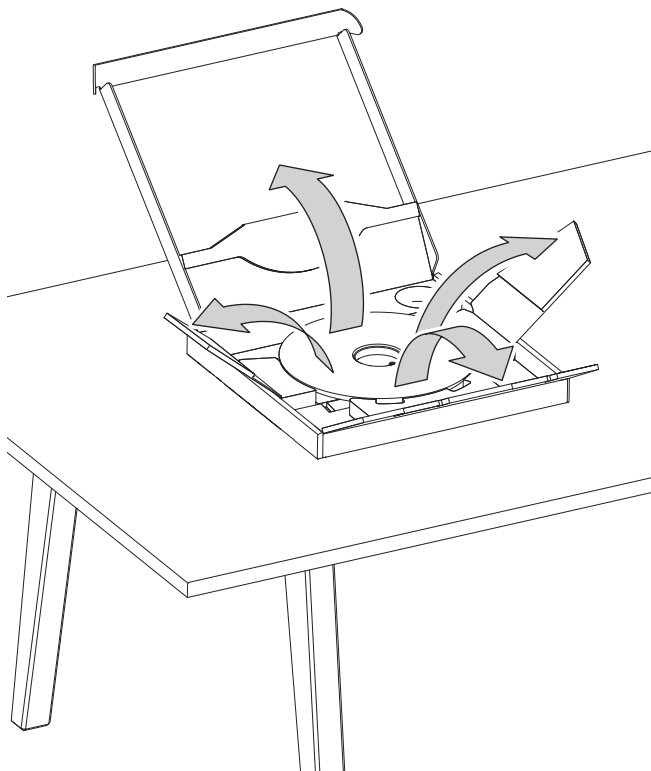

Base anheben und Einleger wie abgebildet aufstellen.

Lift the base and position the inserts as shown.

Relever la base et les inserts, conformément au schéma.

Levante la base y coloque las inserciones como se indica.

Sollevare la base e posizionare gli inserti come illustrato.

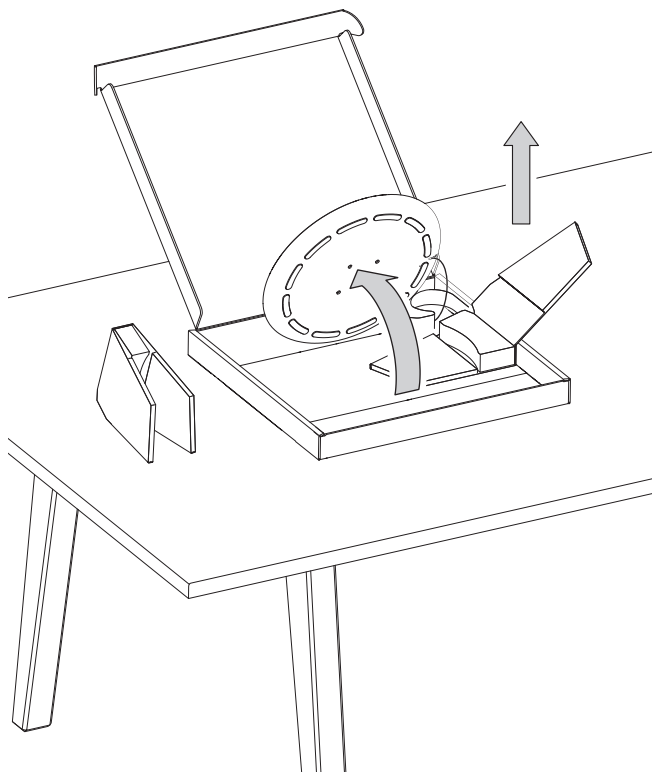

Einleger in die Aussparungen einsetzen.

Insert the inlays in the recesses.

Placer les inserts dans les encoches.

Introduzca las inserciones en las ranuras.

Inserire gli inserti nelle fessure.

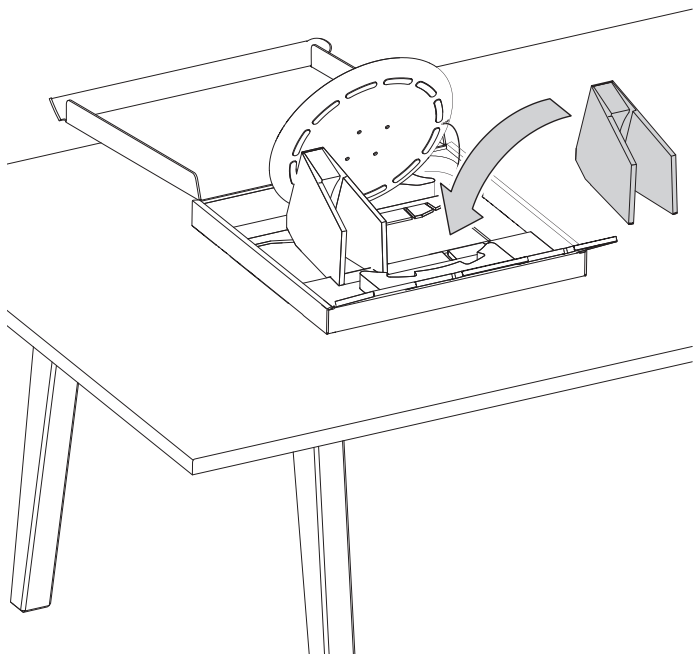

Die untere Lasche der Verpackung umklappen und die base auf den Stützen ablegen.

Turn down the lower flap of packaging and place the base on the supports.

Replier la languette inférieure de l'emballage et poser la base sur les supports.

Doble la solapa inferior del embalaje y coloque la base sobre los soportes.

Ripiegare la linguetta inferiore dell'imballaggio e posizionare la base sui supporti.

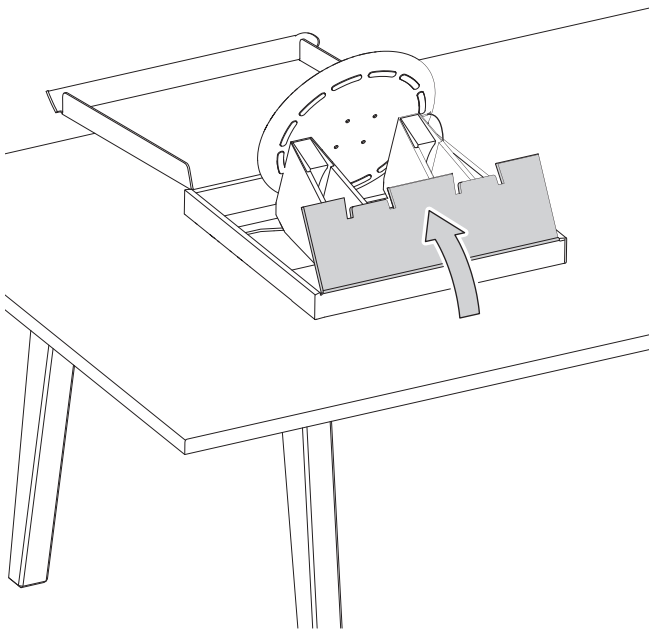

Den unteren body auf die base aufstecken.  
Ausrichtung beachten!

Attach the lower body to the base.  
Note the orientation!

Monter la partie inférieure du corps sur la base.  
Attention à l'orientation !

Fije la parte inferior cuerpo a la base.  
¡Obsérvese la orientación!

Inserire la parte inferiore del corpo sulla base.  
Fare attenzione all'orientamento!

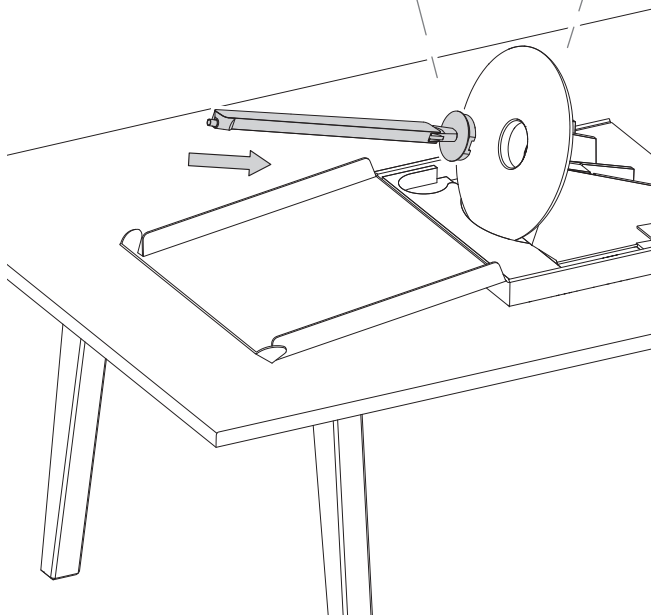
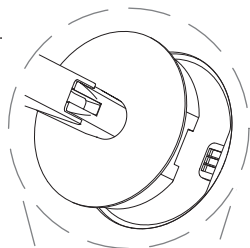

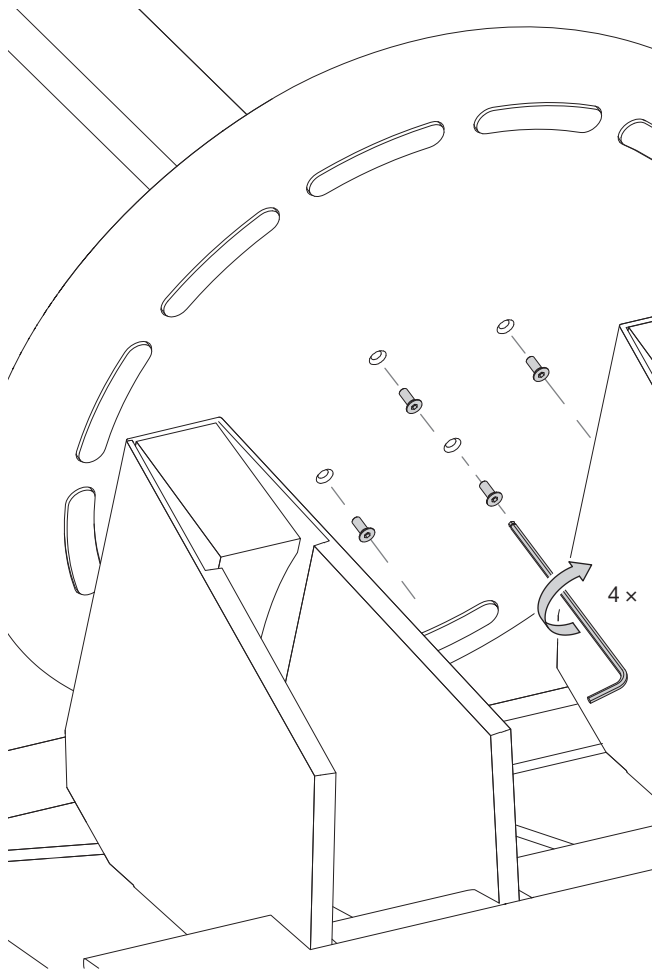

Base und body wie abgebildet,  
der Verpackung, entnehmen.

Remove the base and body  
from the packaging as shown.

Extraire la base et le corps  
de l'emballage, conformément  
au schéma.

Saque la base y el cuerpo del  
embalaje como se muestra.

Rimuovere la base e il corpo dalla  
confezione come illustrato.

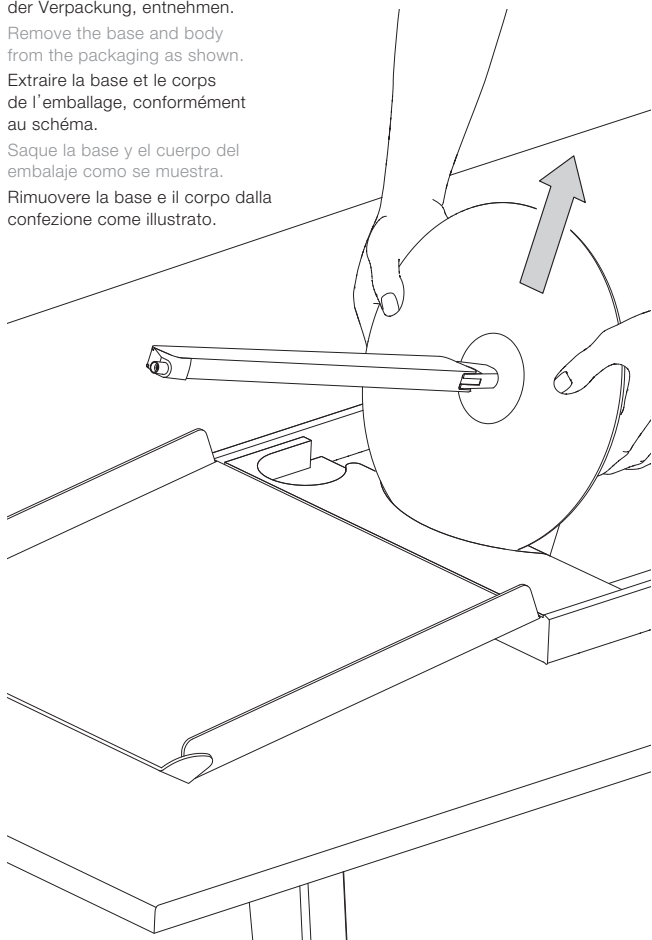



Den oberen body aufstecken.

Attach the upper body.

Brancher la partie supérieure du corps.

Inserte la parte superior del cuerpo.

Inserire la parte superiore del corpo.

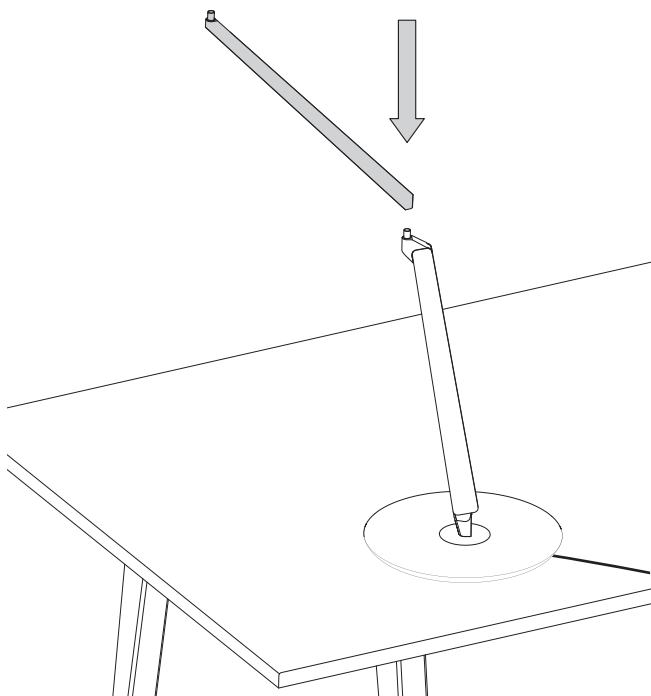

Den head aufstecken.

Attach the head.

Brancher la tête.

Inserte el cabezal.

Inserire la testa.

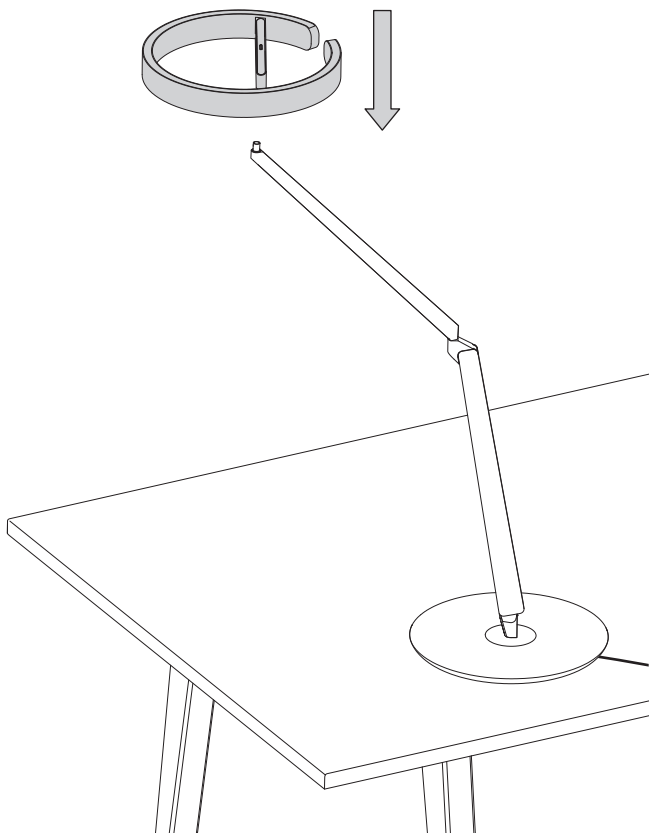

Buchse ausklappen und Kabel einstecken.

Open the socket and insert cable.

Déplier les connecteurs et insérer le câble.

Despliegue enchufe y enchufe el cable.

Aprire la presa e inserire il cavo.

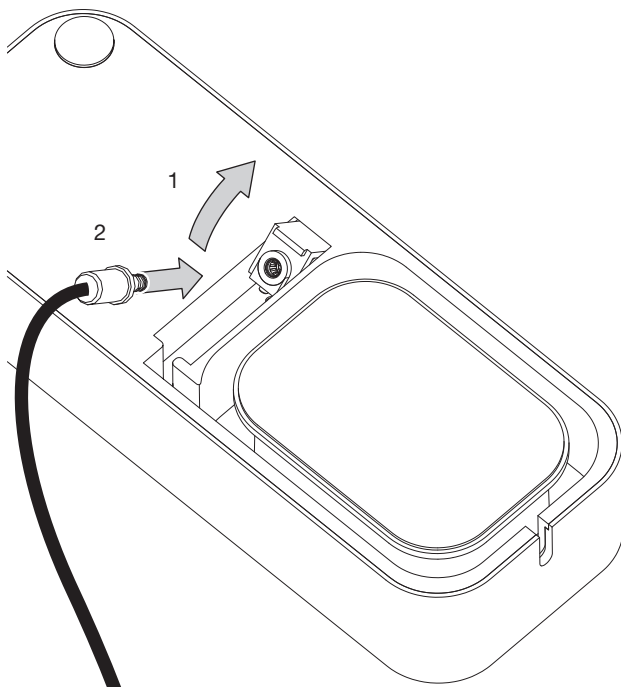

Buchse einklappen und Kabel, bis die gewünschte Länge erreicht ist, aufwickeln.

Close the socket and wrap the cable until it reaches the desired length.

Replier les connecteurs et embobiner le câble jusqu'à obtenir la longueur souhaitée.

Doble el enchufe y enrolla el cable hasta alcanzar la longitud deseada.

Richiudere la presa e avvolgere il cavo fino a raggiungere la lunghezza desiderata.

