

# VIBIA

Assembly instructions / Instrucciones de montaje / Montageanleitung  
Istruzioni di montaggio / Instructions de montage

## Spa

Design by Ramos & Bassols



## Caution

Before assembling and installing this product, carefully read the following:

- Switch off the power supply before installing the lamp.
- To install on the wall, always choose the most adequate fixing tools for the wall material.
- At least 2 people are needed to install and uninstall the lamp.
- This lamp is for indoor use only, excluding bathrooms or any type of damp surface.
- We recommend reading the manual before installing the lamp. Keep this instructions for future reference.
- Do not disassemble, modify or try to repair this fitting. In order to get technical assistance contact VIBIA. Any change or modification to the light fitting may void the manufacturer's warranty.
- All electronic products and batteries must be taken to separate waste collection points at the end of their working lives, they must not be disposed of in normal household waste. It is the responsibility of the user to dispose of the equipment using a designated collection point or service for separate recycling of waste electrical and electronic equipment (WEEE) and batteries according to local laws.

## Precaución

Antes de proceder al montaje e instalación de esta luminaria, leer detenidamente las siguientes consideraciones:

- Desconectar el suministro eléctrico antes de proceder a la instalación de la luminaria.
- Para el montaje de la luminaria a la pared elegir los elementos de fijación más adecuados en función del soporte de instalación.
- Para el montaje y desmontaje de esta luminaria se recomienda la participación de un mínimo de 2 personas.
- Esta luminaria es apta únicamente para su uso en interior, excepto en baños o cualquier tipo de superficie húmeda.
- Recomendamos leer el manual antes de iniciar la instalación de la luminaria. Guardar estas instrucciones para futuras consultas.
- No desmonte, modifique, ni intente reparar la luminaria. Para recibir asistencia técnica, pongase en contacto con VIBIA. Cualquier cambio o modificación en la luminaria puede anular la garantía del fabricante.
- Todos los productos electrónicos y las baterías deben llevarse a puntos de recolección de residuos separados cuando finalicen sus ciclos de vida, no se deben desechar en la cadena normal de residuos con la basura doméstica. Es responsabilidad del usuario desechar los dispositivos en un punto o servicio de recolección designado para el reciclaje separado de residuos de aparatos eléctricos y electrónicos (WEEE), así como las baterías, de conformidad con las leyes locales.

## Vorsicht

Bevor Sie mit der Montage dieser Leuchte beginnen, sollten Sie die folgenden Hinweise in aller Ruhe lesen und berücksichtigen:

- Schalten Sie vor dem elektrischen Anschluss den Strom ab.
- Wählen Sie passend zu der Vorrichtung für die Wandhalterung der Leuchte das dafür geeignete Befestigungsmaterial.
- Für Montage und Demontage dieser Leuchte wird die Beteiligung von mindestens 2 Personen empfohlen.
- Diese Leuchte ist ausschließlich für den Gebrauch im Innenbereich vorgesehen, außer Bädern oder anderen Feuchträumen.
- Wir empfehlen vor Montagebeginn die Anleitung zu lesen. Bewahren Sie die Anleitung für etwaige zukünftige Fragen auf.
- Die Leuchte nicht auseinanderbauen, baulich ändern oder reparieren. Für technische Hilfe VIBIA kontaktieren. Eigenmächtig vorgenommene Änderungen an der Leuchte führen zu einem Verlust der Garantie.
- Alle elektronischen Produkte und Batterien müssen am Ende ihrer Lebensdauer getrennt entsorgt werden, sie dürfen nicht über den normalen Haushaltsmüll entsorgt werden. Es unterliegt der Verantwortung des Benutzers, die Produkte bei einer ausgewiesenen Sammelstelle oder einem Recyclingdienst für elektrische oder elektronische Geräte und Batterien entsprechend der Gesetze vor Ort zu entsorgen (WEEE = Waste of Electrical and Electronic Equipment = Elektro- und Elektronikgeräte-Altgeräte).

## Attenzione

Prima di procedere al montaggio e all'installazione di questo apparecchio, leggere attentamente le seguenti considerazioni:

- Scollegare l'alimentazione prima di procedere all'installazione dell'apparecchio.
- Per il montaggio a parete, usare gli strumenti di fissaggio in base al tipo di materiale della parete.
- Le operazioni di montaggio e smontaggio della lampada devono essere eseguite da un minimo di 2 persone.
- Questo apparecchio è adatto solo per uso interno, ad eccezione dei bagni o di qualsiasi tipo di superficie bagnata.
- Si raccomanda di leggere il manuale prima d'installare la lampada. Conservare le presenti istruzioni per future consultazioni.
- Non smontare, modificare né cercare di riparare la lampada. Per richiedere assistenza tecnica, mettersi in contatto con VIBIA. Qualsiasi cambiamento o modifica alla lampada può annullare la garanzia del fabbricante.
- Tutti i prodotti elettronici e le batterie devono essere smaltiti negli appositi punti di raccolta rifiuti una volta terminato l'utilizzo, non devono mai essere smaltiti con i rifiuti domestici. È responsabilità dell'utente smaltire l'apparecchiatura utilizzando un punto di raccolta o un servizio per il riciclo di rifiuti di apparecchiature elettriche ed elettroniche (RAEE) e batterie secondo le leggi vigenti.

## Attention

Avant de procéder à l'assemblage et à l'installation de ce luminaire, lisez attentivement les considérations suivantes:

- Débranchez l'alimentation avant de procéder à l'installation du luminaire.
- Pour fixer le luminaire au mur, utilisez les éléments de fixation les mieux adaptés au support
- Pour le montage et le démontage de ce luminaire, la présence de 2 personnes est recommandée.
- Ce luminaire ne convient que pour une utilisation en intérieur, sauf dans les salles de bains ou tout type de surface humide.
- Nous vous recommandons de lire le manuel avant de commencer l'installation du luminaire. Gardez ces instructions pour de futures consultations.
- Ne démontez pas le luminaire, ne le modifiez pas et n'essayez pas de le réparer. Pour bénéficier d'une assistance technique, contactez VIBIA. Toute altération ou modification du luminaire peut annuler la garantie du fabricant.
- Tous les produits électroniques et toutes les batteries doivent être apportés à des points de collecte distincts de ceux des ordures ménagères normales lorsqu'ils arrivent en fin de vie. Il incombe à l'utilisateur de se débarrasser de l'équipement dans un point de collecte ou auprès d'un service spécifiquement désigné pour le recyclage des déchets électriques et des équipements électroniques (DEEE) ainsi que des batteries, dans le respect de la législation locale."





**Step 1**  
Product Spec Sheet



**Step 2**  
Supplied Materials



**Step 3**  
Installation Preparation



**Step 4**  
Electrical Connection



**Step 5**  
Product Assembly





Step 1/5

# Product Spec Sheet

Technical specifications / Especificaciones técnicas / Technische Daten  
Specifiche tecniche / Caractéristiques techniques

5981

Net Weight / Peso Neto / Netto-Gewicht 2,80 kg  1 x LED STRIP 10,8W 600mA        ~ 

5983

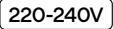
Net Weight / Peso Neto / Netto-Gewicht 4,80 kg  1 x LED STRIP 21,6W 600mA        ~ 



**Class I.** Product with an additional protection cable (grounds).

**Clase I.** Aparato con un cable protector adicional (toma de tierra).

**Klasse I.** Apparat mit zusätzlichen Schutzleiter (Erdkabel).

**Classe I.** Apparecchio con un cavo di protezione aggiuntivo (presa di terra).

**Classe I.** Appareil avec câble d'isolation additionnel (borne de terre).

**IP44**

Product protected against solid object as big as or bigger than 1 mm. Protected against water trickles.

Producto protegido contra la penetración de cuerpos sólidos de tamaño igual o superior a 1 mm. Protegido contra chorros de agua.

Produkt ist geschützt gegen das Eindringen von Fremdkörpern >1 mm. Schutz gegen das Eindringen von Strahlwasser.

Prodotto protetto contro la penetrazione di corpi solidi di dimensioni pari o superiori a 1 mm. Protetto contro i rivoli d'acqua.

Produit protégé contre les intrusions de corps solides de taille égale ou supérieure à 1 mm. Protégé contre les jets d'eau de toutes directions à la lance.

**220-240V**

Rango de voltaje

Voltage range

Spannungsbereich

Campo di tensione

Gamme de tension

220-240V



Alternating current

Corriente alterna

Wechselstrom

Corrente alternata

Courant alternatif

50/60Hz



Step 2/5

## Supplied Materials

Supplied material / Material suministrado / Geliefertes Material  
Materiale incluso / Matériel fourni

	5981	5983
1. Allen key / Llave allen / Inbusschlüssel / Chiave a brugola / Clé Allen	1 un.	1 un.
2. Tube spanner / Llave de tubo / Steckschlüssel / Chiave a tubo / Clé à douille	1 un.	1 un.
3. Marker / Marcador / Marker / Marcatore / Marqueur	1 un.	1 un.
4. Holder / Soporte / Halterin / Marcatore / Marqueur	1 un.	1 un.
5. Decorative cover / Embellecedor / Dekorative Abdeckung / Copertura decorativa / Rosace	2 un.	2 un.
6. Casambi + Wiring box / Casambi + Caja de conexión / Casambi + Klemmenkasten / Casambi + Scatola di connessione / Casambi + Boîte de connexion	1 un.	1 un.
7. Lighting fixture / Estructura luminaria / Leuchtenstruktur / Struttura lampada / Structure du luminaire	1 un.	1 un.

1



2



3



4

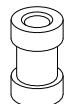

5



6

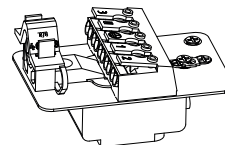

-Only for product dimmer CASAMBI  
-Solo para los productos con regulación CASAMBI  
-Nur für Produkte mit CASAMBI-Regulierung  
-Solo per i prodotti con regolazione CASAMBI  
-Uniquement pour les produits smart Casambi

7

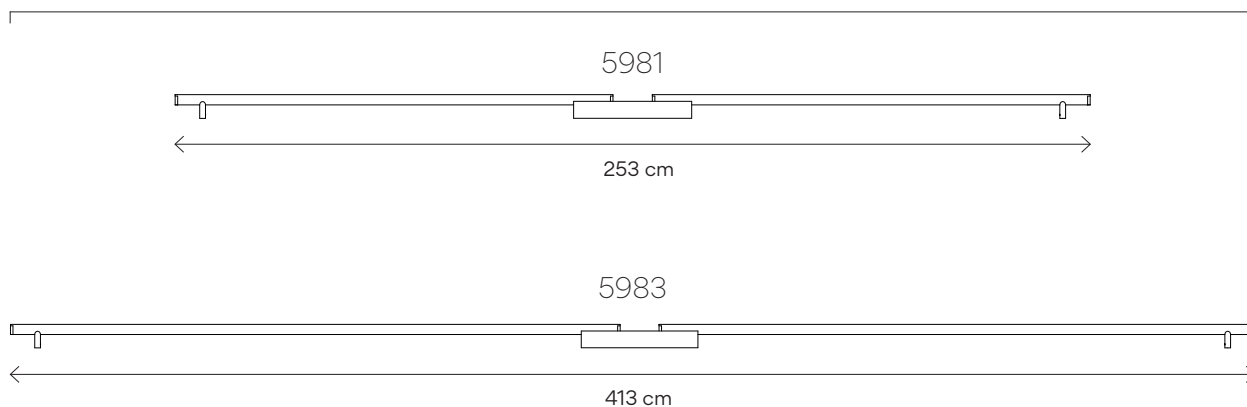



# Step 3/5 Installation Preparation

5981

POSITION 1

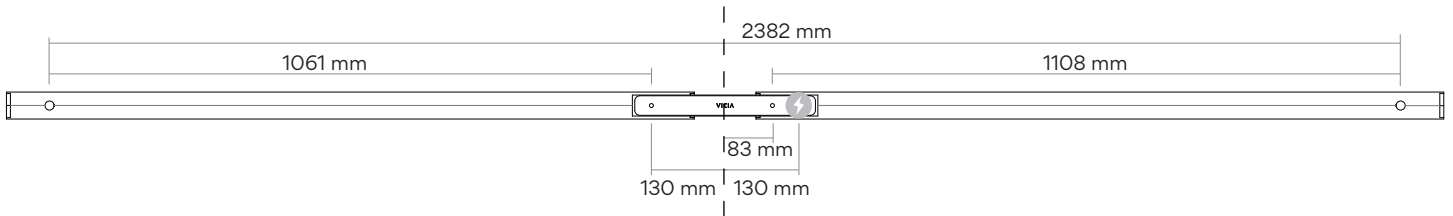

POSITION 2

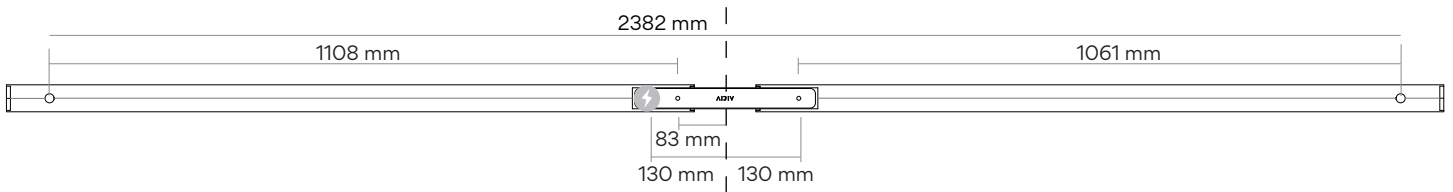

5983

POSITION 1

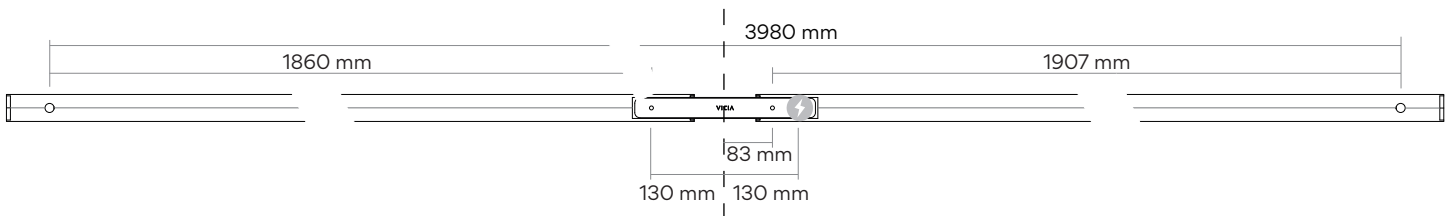

POSITION 2

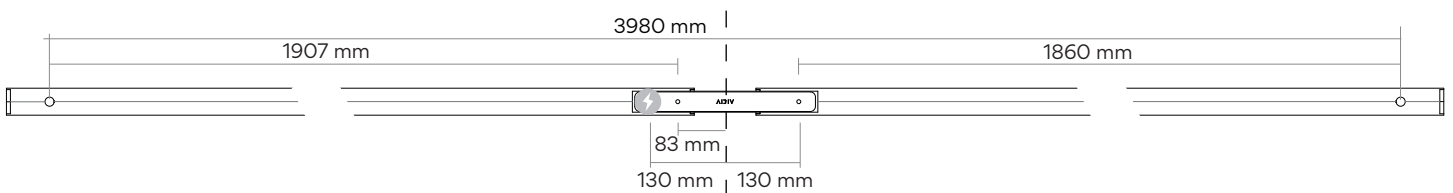



Step 3/5  
Installation Preparation

3.1

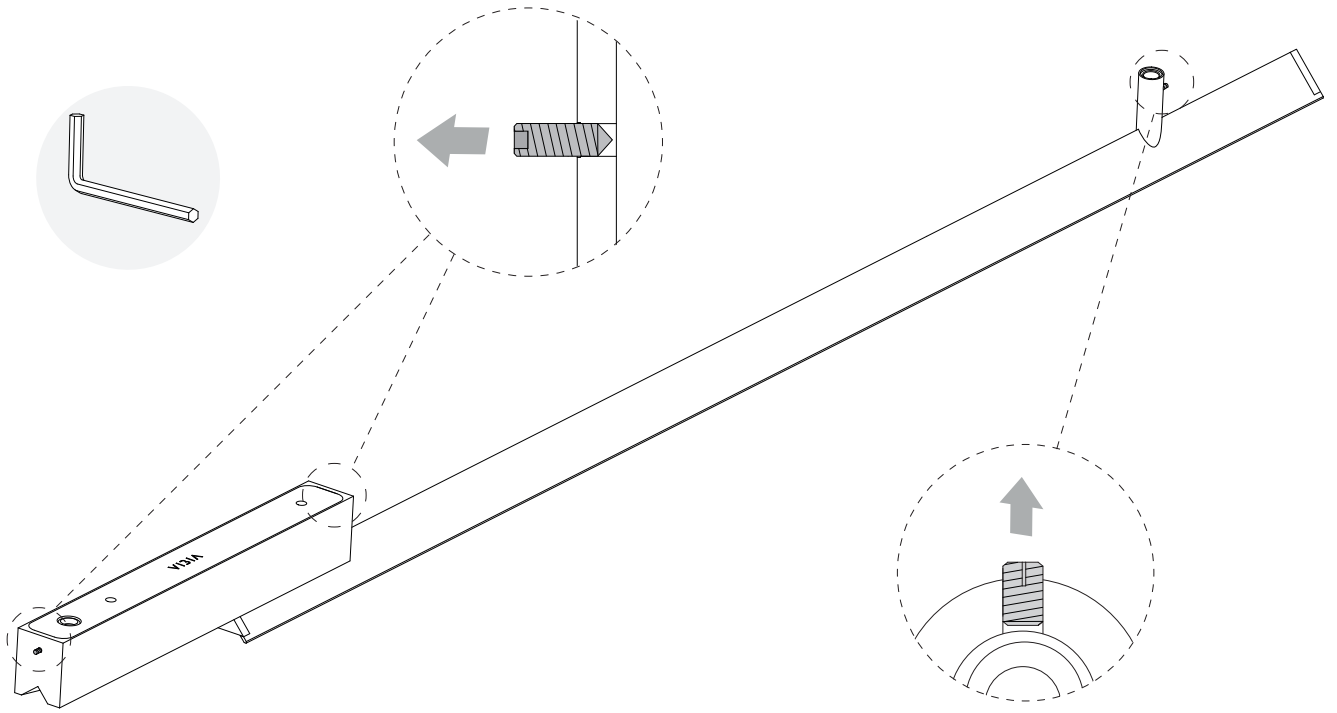

3.2

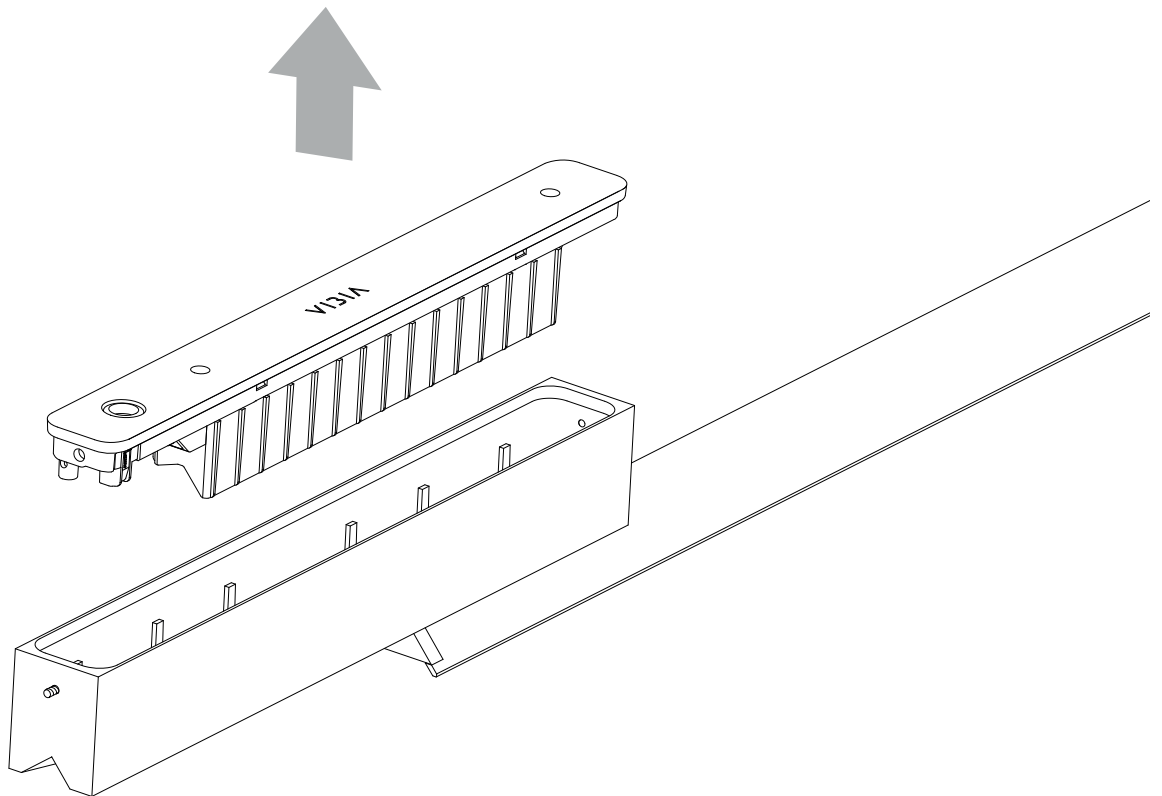



## Step 3/5 Installation Preparation

### 3.3



- Wall plugs (not supplied)
- Tacos de fijación (no suministrados)
- Dübel (nicht im Lieferumfang)
- Tasselli di fissaggio (non inclusi)
- Chevilles de fixation (non fournies)

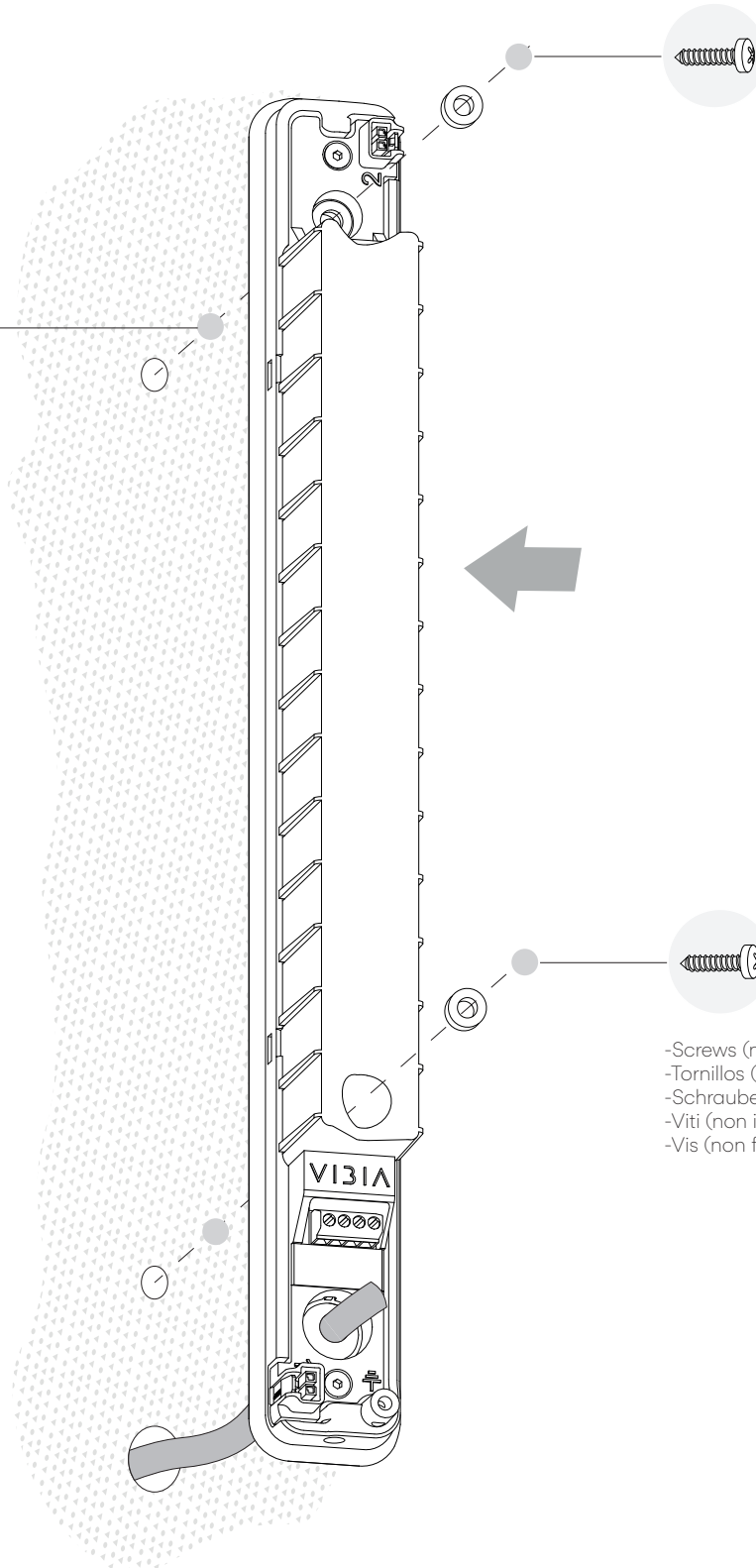

- Screws (not supplied)
- Tornillos (no suministrados)
- Schrauben (nicht im Lieferumfang)
- Viti (non incluse)
- Vis (non fournies)





## Step 4/5 Electrical Connection

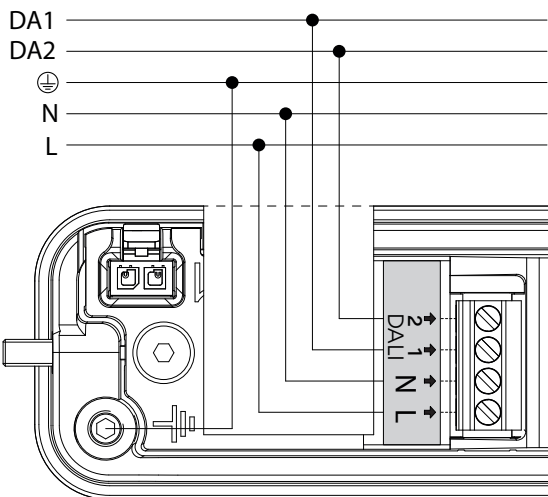
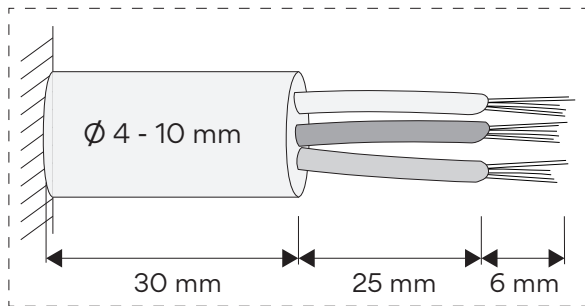
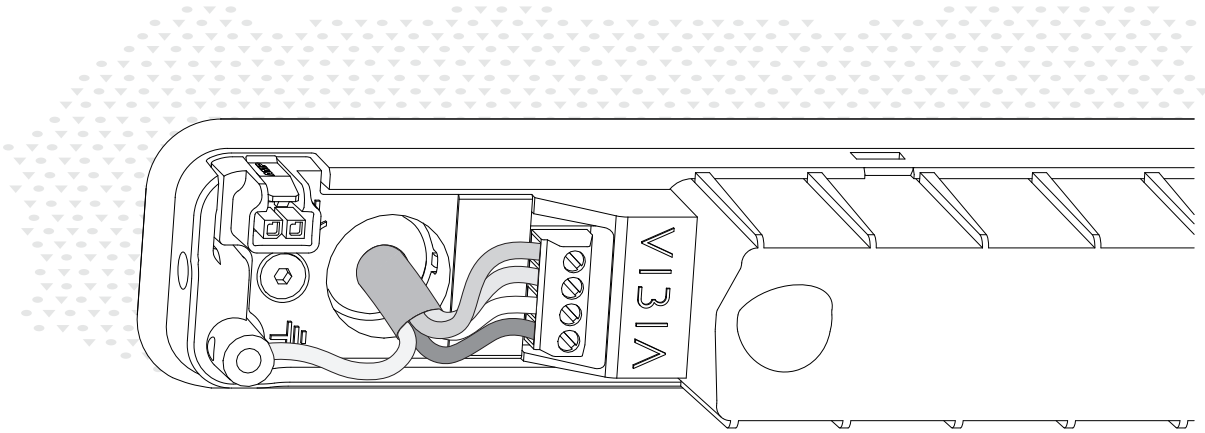

- DALI SYSTEM DIMMING
- REGULACIÓN MEDIANTE SISTEMA DALI
- DIMMER MIT DALI-SYSTEM
- REGOLAZIONE MEDIANTE SISTEMA DALI
- RÉGLAGE À LAIDE DU SYSTÈME DALI

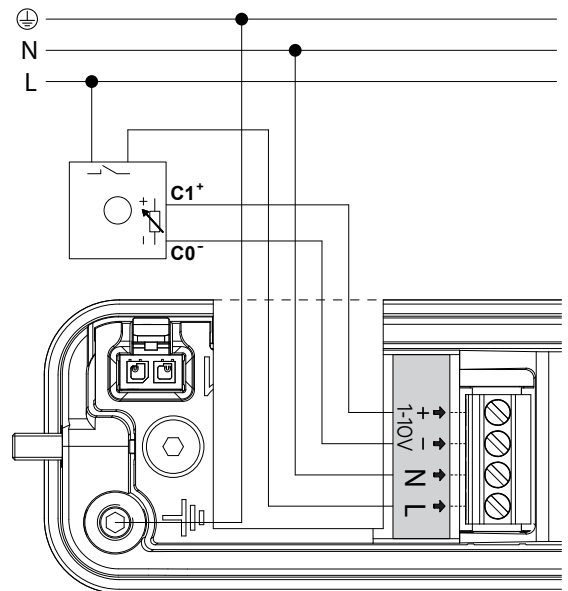

- 1-10V SYSTEM DIMMING
- REGULACIÓN MEDIANTE SISTEMA 1-10 V
- DIMMBAR 1-10V-SYSTEM
- REGOLAZIONE MEDIANTE 1-10V
- VARIATEUR DE PUISSANCE 1-10V



# Step 4/5 Electrical Connection

SMART CASAMBI

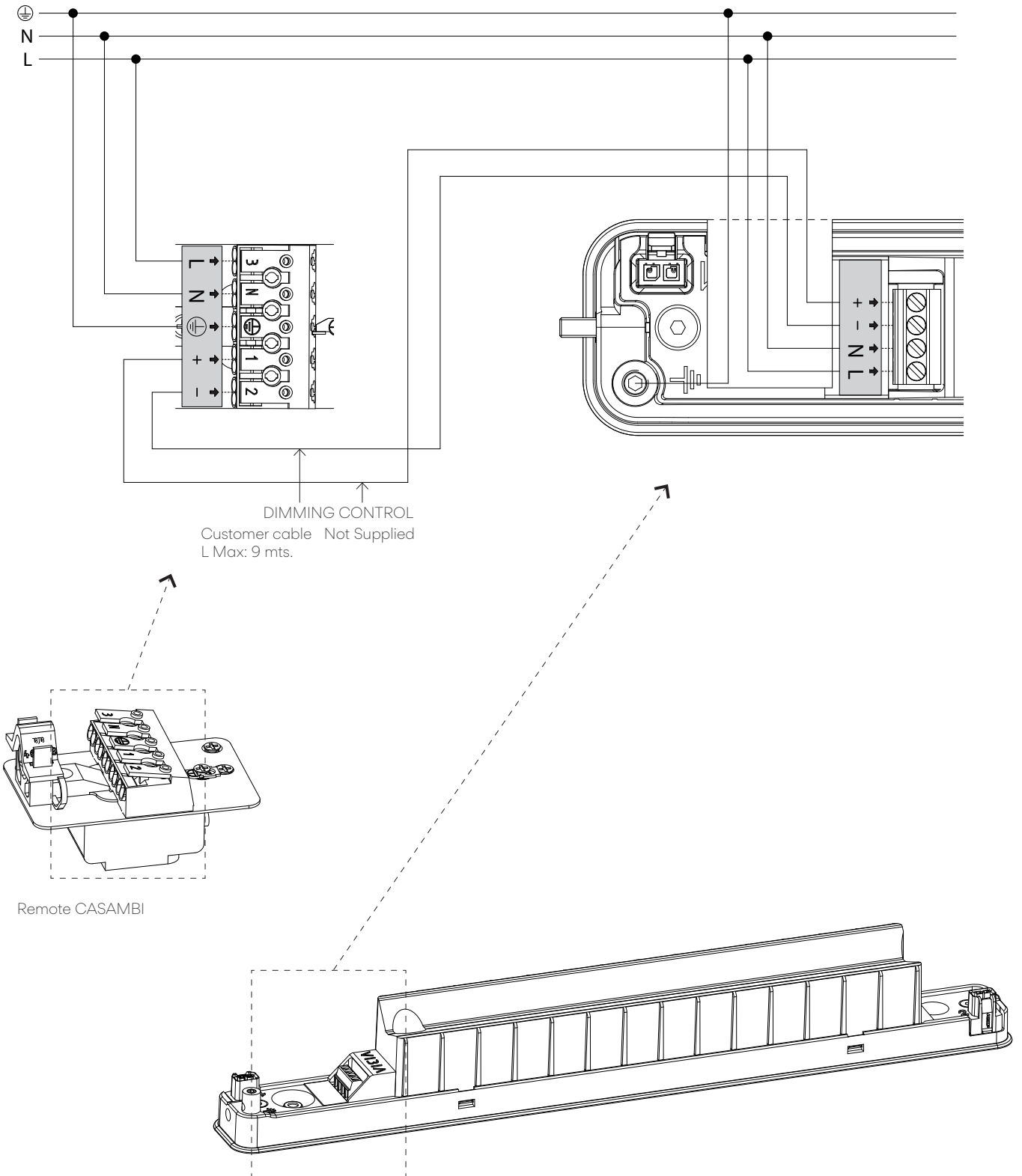



## Step 5/5 Product Assembly

### 5.1

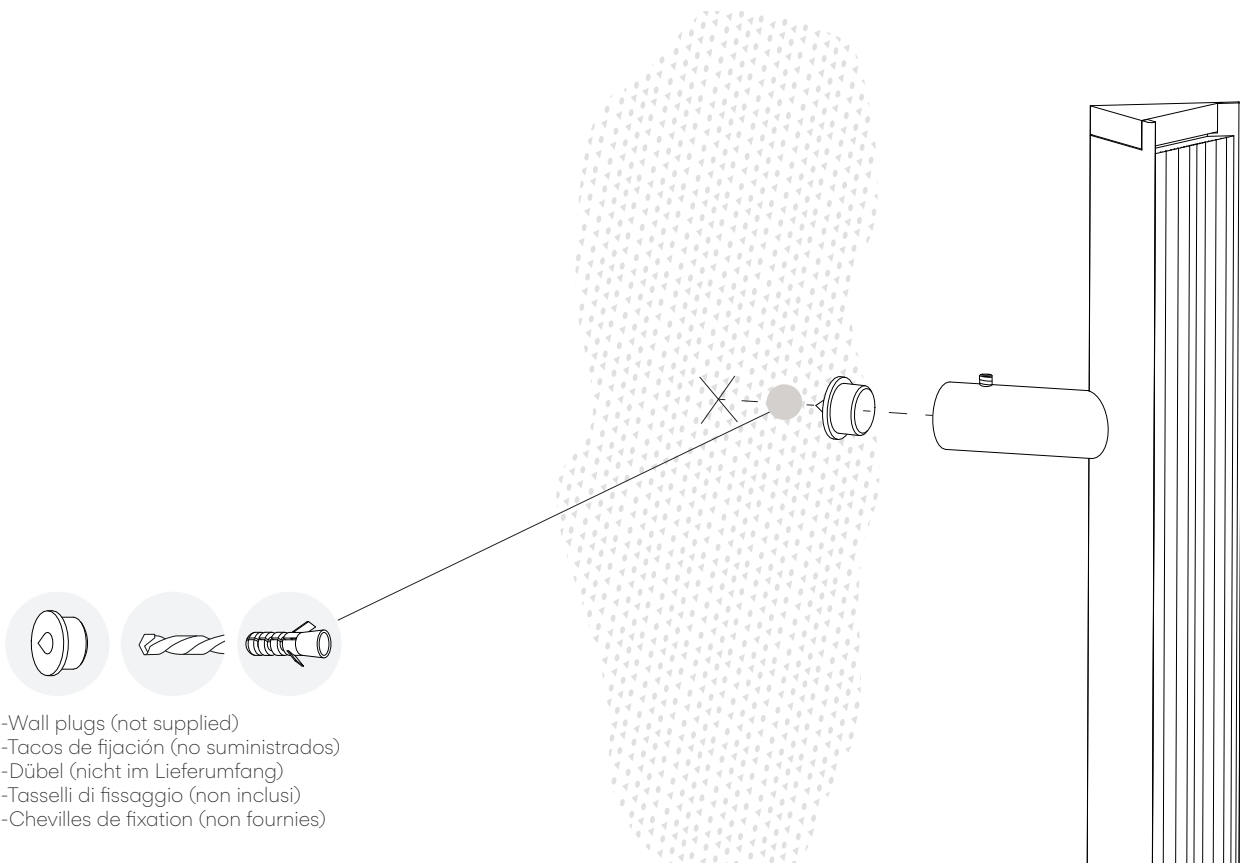

### 5.2

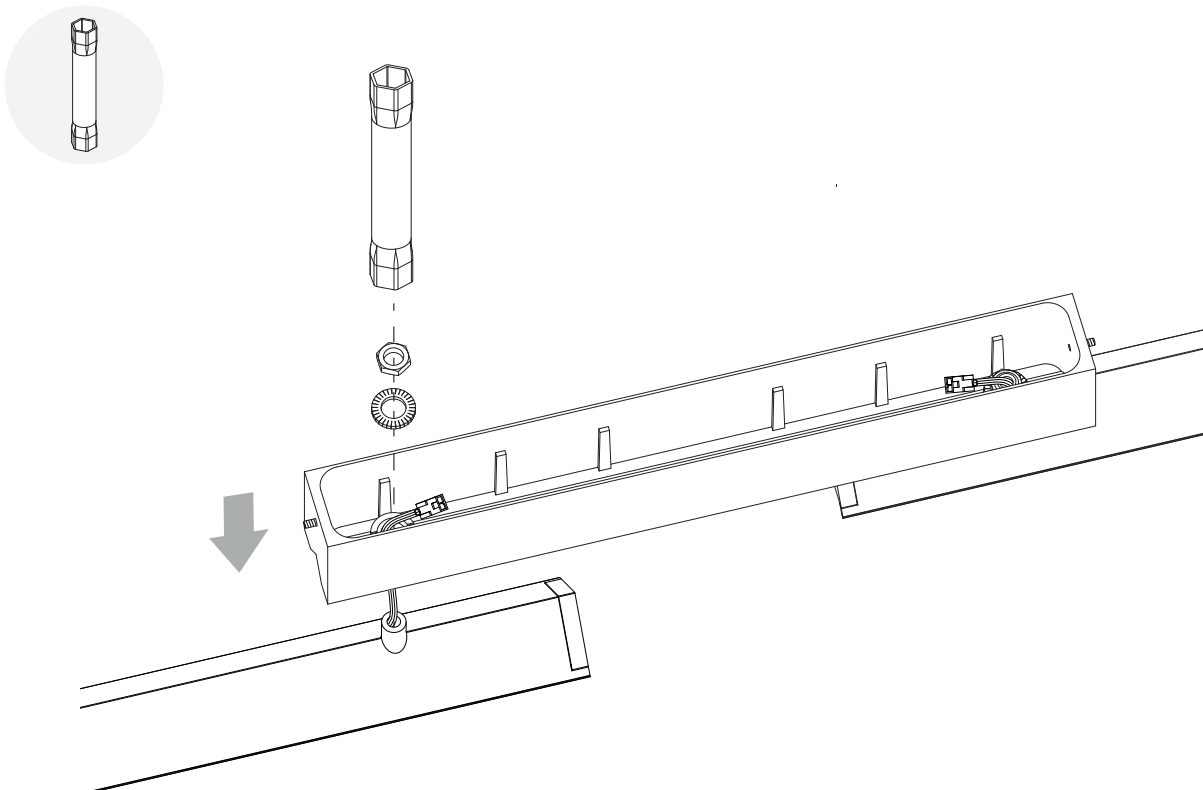



# Step 5/5 Product Assembly

## 5.3

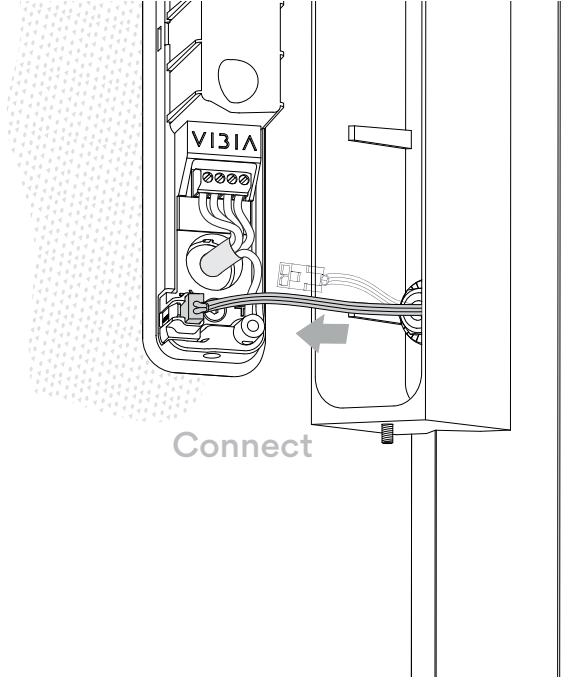
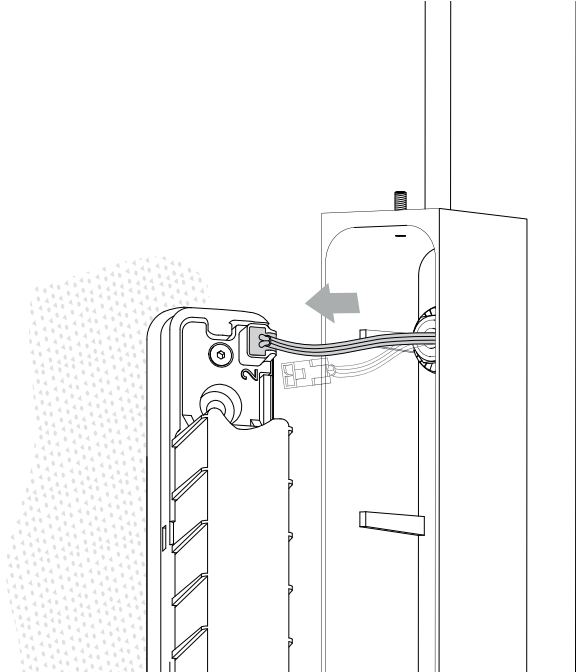

## 5.4

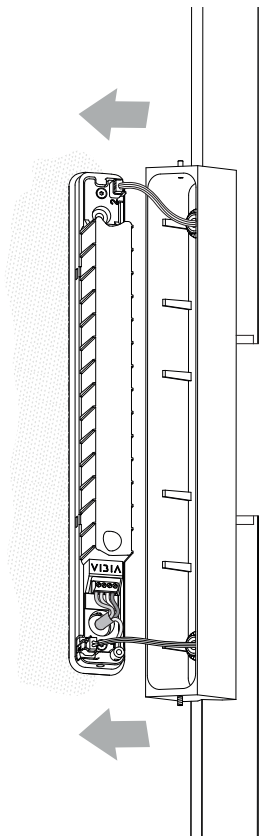

## 5.5

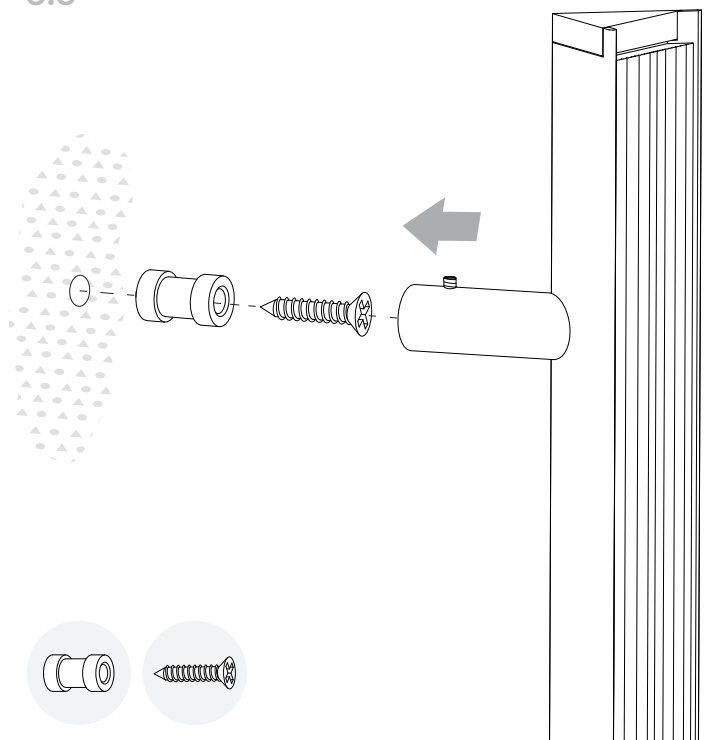

- Screws (not supplied)
- Tornillos (no suministrados)
- Schrauben (nicht im Lieferumfang)
- Viti (non incluse)
- Vis (non fournies)



Step 5/5  
Product Assembly

5.6

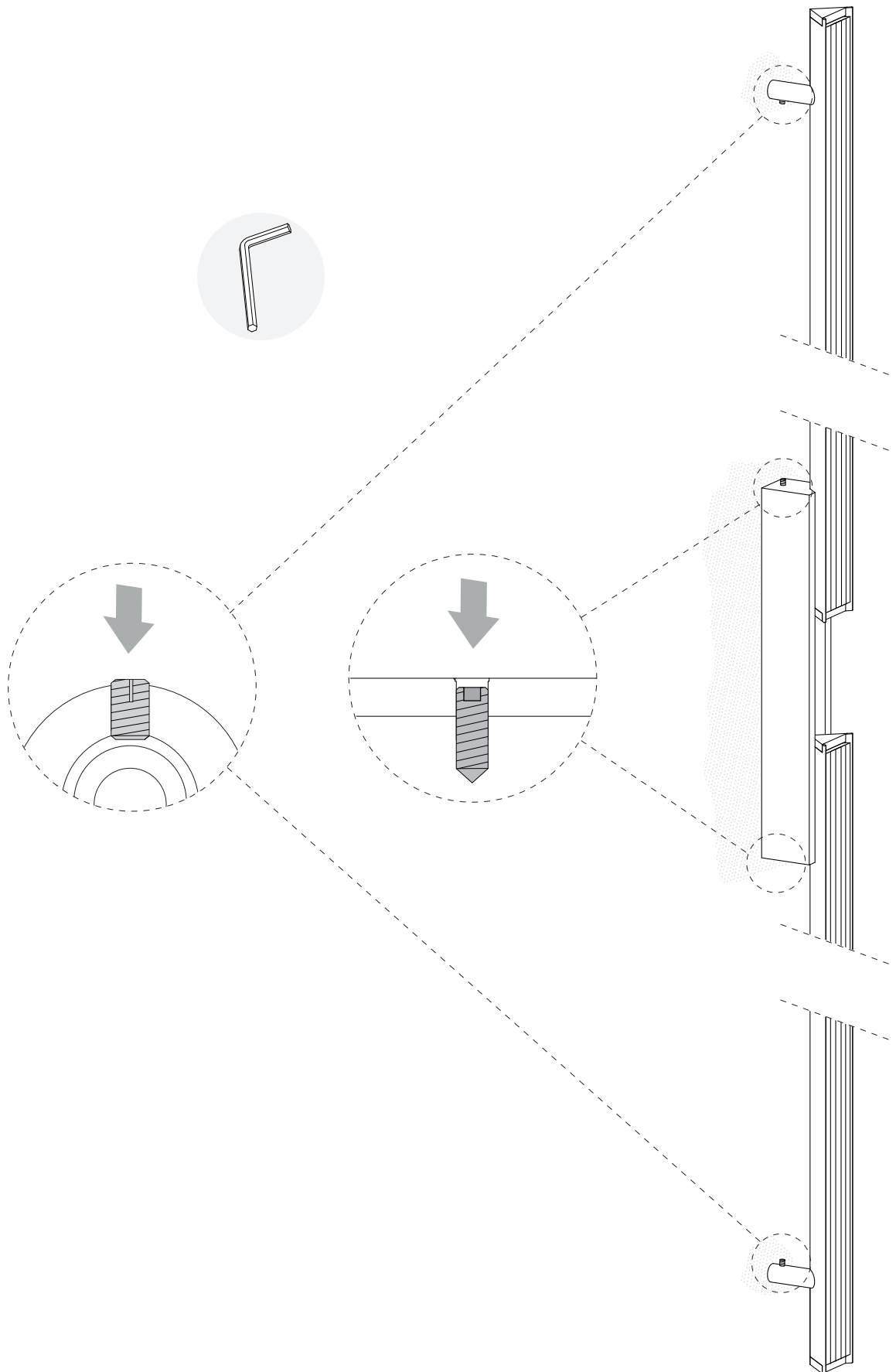

---

## Maintenance

Use a slightly-wet cotton cloth for cleaning.

In case of malfunction or damage, please contact the retailer who sold the lamp.

---

## Mantenimiento

Para limpiar la luminaria, usar un paño de algodón ligeramente humedecido en agua.

En caso de avería o incidente con la luminaria, contactar directamente con el establecimiento en que se adquirió.

---

## Instandhaltung

Zur Reinigung der Leuchte nutzen Sie einen leicht angefeuchteten Baumwoll-Lappen.

Im Falle des Ausfalls oder einer Fehlfunktion der Leuchte setzen Sie sich direkt mit dem Unternehmen in Verbindung bei dem Sie die Leuchte bezogen haben.

---

## Manutenzione

Per la pulizia della lampada, usare un panno di cotone leggermente inumidito con acqua.

In caso di guasto o incidente con la lampada, rivolgersi direttamente al rivenditore da cui è stata acquistata.

---

## Entretien

Pour nettoyer le luminaire, utilisez un chiffon en coton légèrement humidifié d'eau.

En cas d'incident ou de défaillance du luminaire, contactez directement l'établissement où vous l'avez acheté.

Vibia Lighting, S.L.U.

Spain & Portugal T. +34 934 796 970

International T. +34 934 796 971

customer.service@vibia.com

www.vibia.com

VIBIA