

# VIBIA

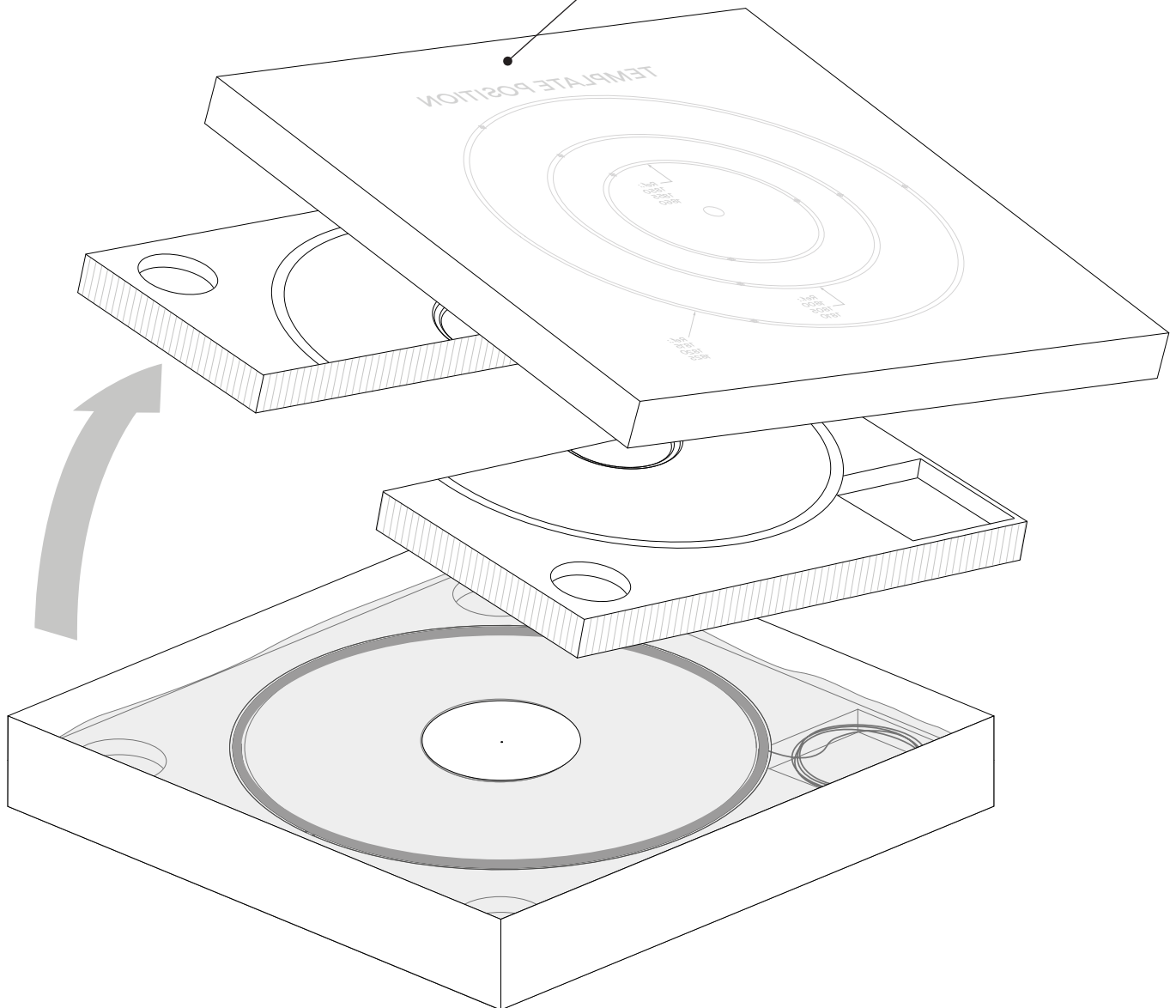

- Keep the marking tool
- Conservar el útil de marcaje
- Behalten Sie das Markierungshilfe
- Preservare il utensile di marcatura
- Conserver l'outil de marquage





# VIBIA

Assembly instructions / Instrucciones de montaje / Montageanleitung  
Istruzioni di montaggio / Instructions de montage

## Array

Design by Umut Yamac



## Caution

Before assembling and installing this product, carefully read the following:

- Switch off the power supply before installing the lamp.
- To install on the ceiling, always choose the most adequate fixing tools for the ceiling material.
- This lamp is for indoor use only, excluding bathrooms or any type of humid surface.
- Consult the electrical specifications on the product marking.
- We recommend reading the manual before installing the lamp. Keep this instructions for future reference.
- Do not disassemble, modify or try to repair this fitting. In order to get technical assistance contact VIBIA. Any change or modification to the light fitting can null the manufacturer's guarantee.
- All electronic products and batteries must be taken to separate waste collection points at the end of their working lives, they must not be disposed of in normal household waste. It is the responsibility of the user to dispose of the equipment using a designated collection point or service for separate recycling of waste electrical and electronic equipment (WEEE) and batteries according to local laws.
- At least two people are needed to install and uninstall the lamp.
- Due to the craftsmanship of the textile elements that make up the Array pendant, the length of the luminaires may vary slightly from the published measurements.

## Precaución

Antes de proceder al montaje e instalación de esta luminaria, leer detenidamente las siguientes consideraciones:

- Desconectar el suministro eléctrico antes de proceder a la instalación de la luminaria.
- Para el montaje de la luminaria al techo elegir los elementos de fijación mas adecuados en función del soporte de instalación.
- Esta luminaria es apta únicamente para su uso en interior, excepto en baños o cualquier tipo de superficie húmeda.
- Consultar las especificaciones eléctricas en el mercado del producto.
- Recomendamos leer el manual antes de iniciar la instalación de la luminaria. Guardar estas instrucciones para futuras consultas.
- No desmonte, modifique, ni intente reparar la luminaria. Para recibir asistencia técnica, pongase en contacto con VIBIA. Cualquier cambio o modificación en la luminaria puede anular la garantía del fabricante.
- Todos los productos electrónicos y las baterías deben llevarse a puntos de recolección de residuos separados cuando finalicen sus ciclos de vida, no se deben desechar en la cadena normal de residuos con la basura doméstica. Es responsabilidad del usuario desechar los dispositivos en un punto o servicio de recolección designado para el reciclaje separado de residuos de aparatos eléctricos y electrónicos (WEEE), así como las baterías, de conformidad con las leyes locales.
- Para el montaje y desmontaje de esta luminaria se recomienda la participación de un mínimo de dos personas.
- Debido al proceso artesanal de los elementos textiles que componen el colgante Array, la longitud de las luminarias pueden variar ligeramente respecto a las medidas publicadas.

## Vorsicht

Bevor Sie mit der Montage dieser Leuchte beginnen, sollten Sie die folgenden Hinweise in aller Ruhe lesen und berücksichtigen:

- Schalten Sie vor dem elektrischen Anschluss den Strom ab.
- Wählen Sie passend zu der Vorrichtung für die Deckenmontage der Leuchte das dafür geeignete Befestigungsmaterial.
- Diese Leuchte ist ausschliesslich für den Gebrauch im Innenbereich vorgesehen, ausser Bädern oder anderen Feuchträumen.
- Beachten Sie die elektrischen Spezifikationen auf der Produktkennzeichnung.
- Wir empfehlen vor Montagebeginn die Anleitung zu lesen. Bewahren Sie die Anleitung für etwaige zukünftige Fragen auf.
- Die Leuchte nicht auseinanderbauen, baulich ändern oder reparieren. Für technische Hilfe VIBIA kontaktieren. Eigenmächtig vorgenommene Änderungen an der Leuchte führen zu einem Verlust der Garantie.
- Alle elektronischen Produkte und Batterien am Ende Ihrer Lebensdauer getrennt entsorgt werden müssen, sie dürfen nicht über den normalen Fluss des Haushaltsmülls entsorgt werden. Es unterliegt der Verantwortlichkeit des Benutzers, die Ausrüstung unter Verwendung einer ausgewiesenen Sammelstelle oder eines Dienstes für getrenntes Recycling von elektrischen Geräten und Batterien entsprechend der Gesetz vor Ort zu entsorgen (WEEE = Waste of Electrical and Electronic Equipment = Elektro - und Elektronikgeräte - Abfall).
- Für Montage und Demontage dieser Leuchte wird die Beteiligung von mindestens 2 Personen empfohlen.
- Aufgrund der handwerklichen Verarbeitung der Textilelemente, aus denen die Array Pendelleuchte besteht, kann die Länge der Leuchten leicht von den veröffentlichten Maßen abweichen.

## Attenzione

Prima di procedere al montaggio e all'installazione di questo apparecchio, leggere attentamente le seguenti considerazioni:

- Scollegare l'alimentazione prima di procedere all'installazione dell'apparecchio.
- Per il montaggio della lampada al soffitto, usare gli strumenti di fissaggio più adeguati in base alla superficie di installazione.
- Questo apparecchio è adatto solo per uso interno, ad eccezione dei bagni o di qualsiasi tipo di superficie bagnata.
- Consultare le specifiche elettriche sulla marcatura del prodotto.
- Si consiglia di leggere il manuale prima di iniziare l'installazione dell'apparecchio. Salva queste istruzioni per future consultazioni.
- Non smontare, modificare né cercare di riparare la lampada. Per richiedere assistenza tecnica, mettersi in contatto con VIBIA. Qualsiasi cambiamento o modifica alla lampada può annullare la garanzia del fabbricante.
- Tutti i prodotti elettronici e le batterie devono essere separate in punti di raccolta dei rifiuti una volta terminato l'utilizzo, non devono essere smaltiti nel normale flusso dei rifiuti insieme ai rifiuti domestici. È responsabilità dell'utente smaltire l'apparecchiatura utilizzando un punto di raccolta o un servizio per il riciclo di rifiuti di apparecchiature elettriche ed elettroniche (RAEE) e batterie secondo le leggi vigenti.
- Le operazioni di montaggio e smontaggio della lampada devono essere eseguite da un minimo di due persone.
- A causa della lavorazione artigianale degli elementi tessili che compongono la sospensione Array, la lunghezza delle lampade può variare leggermente rispetto alle misure pubblicate.

## Attention

Avant de procéder à l'assemblage et à l'installation de ce luminaire, lisez attentivement les considérations suivantes:

- Débranchez l'alimentation avant de procéder à l'installation du luminaire.
- Pour fixer le luminaire au plafond, utilisez les éléments de fixation les mieux adaptés au support.
- Ce luminaire ne convient que pour une utilisation en intérieur, sauf dans les salles de bains ou tout type de surface humide.
- Consultez les spécifications électriques sur le marquage du produit.
- Nous vous recommandons de lire le manuel avant de commencer l'installation du luminaire. Sauvegardez ces instructions pour futures consultations.
- Ne démontez pas le luminaire, ne le modifiez pas et n'essayez pas de le réparer. Pour bénéficier d'une assistance technique, contactez VIBIA. Toute altération ou modification du luminaire peut annuler la garantie du fabricant.
- Tous les produits électroniques et toutes les batteries doivent être apportés à des points de collecte distincts de ceux des orsures ménagères normales lorsqu'ils arrivent en fin de vie. Il incombe à l'utilisateur de se débarrasser de l'équipement dans un point de collecte ou auprès d'un service spécifiquement désigné pour le recyclage des déchets électriques et des équipements électroniques (DEEE) ainsi que des batteries, dans le respect de la législation locale.
- Pour le montage et le démontage de ce luminaire, la présence de deux personnes est recommandée.
- En raison de la fabrication artisanale des éléments textiles qui composent la suspension Array, la longueur des luminaires peut varier légèrement par rapport aux mesures publiées.





**Step 1**  
Product Spec Sheet



**Step 2**  
Supplied Materials



**Step 3**  
Installation Preparation



**Step 4**  
Electrical Connection



**Step 5**  
Product Assembly











































































































































**Step 6**  
Adjustments & Maintenance



## Step 1/6 Product Spec Sheet

Technical specifications / Especificaciones técnicas / Technische Daten  
Specifiche tecniche / Caractéristiques techniques

	<b>1800</b> Height: 73 cm  Net Weight: 4,8 Kg.  1 x LED STRIP 22W 48V  <b>IP20</b> <b>Multi-volt</b> <b>Dimmer</b>     <b>50-60Hz</b>
	<b>1805</b> Height: 113 cm  Net Weight: 5,1 Kg.  1 x LED STRIP 22W 48V  <b>IP20</b> <b>Multi-volt</b> <b>Dimmer</b>     <b>50-60Hz</b>
	<b>1810</b> Height: 193 cm  Net Weight: 5,4 Kg.  1 x LED STRIP 22W 48V  <b>IP20</b> <b>Multi-volt</b> <b>Dimmer</b>     <b>50-60Hz</b>
	<b>1815</b> Height: 73 cm  Net Weight: 6,2 Kg.  1 x LED STRIP 33W 48V  <b>IP20</b> <b>Multi-volt</b> <b>Dimmer</b>     <b>50-60Hz</b>
	<b>1820</b> Height: 113 cm  Net Weight: 6,6 Kg.  1 x LED STRIP 33W 48V  <b>IP20</b> <b>Multi-volt</b> <b>Dimmer</b>     <b>50-60Hz</b>
	<b>1825</b> Height: 193 cm  Net Weight: 7,1 Kg.  1 x LED STRIP 33W 48V  <b>IP20</b> <b>Multi-volt</b> <b>Dimmer</b>     <b>50-60Hz</b>
	<b>1830</b> Height: 113 cm  Net Weight: 9,5 Kg.  1 x LED STRIP 50W 48V  <b>IP20</b> <b>Multi-volt</b> <b>Dimmer</b>     <b>50-60Hz</b>
	<b>1835</b> Height: 193 cm  Net Weight: 10,1 Kg.  1 x LED STRIP 50W 48V  <b>IP20</b> <b>Multi-volt</b> <b>Dimmer</b>     <b>50-60Hz</b>
	<b>1840</b> Height: 113 cm  Net Weight: 13,1 Kg.  1 x LED STRIP 76W 48V  <b>IP20</b> <b>Multi-volt</b> <b>Dimmer</b>     <b>50-60Hz</b>
	<b>1845</b> Height: 193 cm  Net Weight: 13,9 Kg.  1 x LED STRIP 76W 48V  <b>IP20</b> <b>Multi-volt</b> <b>Dimmer</b>     <b>50-60Hz</b>
	<b>1850</b> Height: 71 cm  Net Weight: 5,7 Kg.  1 x LED STRIP 33W 48V  <b>IP20</b> <b>Multi-volt</b> <b>Dimmer</b>     <b>50-60Hz</b>
	<b>1855</b> Height: 112 cm  Net Weight: 6,1 Kg.  1 x LED STRIP 33W 48V  <b>IP20</b> <b>Multi-volt</b> <b>Dimmer</b>     <b>50-60Hz</b>
	<b>1860</b> Height: 192 cm  Net Weight: 6,5 Kg.  1 x LED STRIP 33W 48V  <b>IP20</b> <b>Multi-volt</b> <b>Dimmer</b>     <b>50-60Hz</b>
	<b>1865</b> Height: 110 cm  Net Weight: 8,8 Kg.  1 x LED STRIP 50W 48V  <b>IP20</b> <b>Multi-volt</b> <b>Dimmer</b>     <b>50-60Hz</b>
	<b>1870</b> Height: 191 cm  Net Weight: 9,4 Kg.  1 x LED STRIP 50W 48V  <b>IP20</b> <b>Multi-volt</b> <b>Dimmer</b>     <b>50-60Hz</b>
	<b>1875</b> Height: 107 cm  Net Weight: 11,9 Kg.  1 x LED STRIP 76W 48V  <b>IP20</b> <b>Multi-volt</b> <b>Dimmer</b>     <b>50-60Hz</b>
	<b>1880</b> Height: 190 cm  Net Weight: 12,8 Kg.  1 x LED STRIP 76W 48V  <b>IP20</b> <b>Multi-volt</b> <b>Dimmer</b>     <b>50-60Hz</b>



**Class I.** Product with an additional protection cable (grounds).

**Clase I.** Aparato con un cable protector adicional (toma de tierra).

**Klasse I.** Apparat mit zusätzlichen Schutzleiter (Erdkabel).

**Classe I.** Apparecchio con un cavo di protezione aggiuntivo (presa di terra).

**Classe I.** Appareil avec câble d'isolation additionnel (borne de terre).

**IP20**

Product protected against solid object as big as or bigger than 12 mm. No protection against water.

Producto protegido contra la penetración de cuerpos sólidos de tamaño igual o superior a 12mm. Sin protección al agua.

Produkt ist geschützt gegen das Eindringen von Fremdkörpern >12mm. Kein Schutz gegen Eindringen von Wasser.

Prodotto protetto contro la penetrazione di corpi solidi di dimensioni pari o superiori a 12 mm. Non protetto dall'acqua.

Produit protégé contre les intrusions de corps solides de taille égale ou supérieure à 12 mm. Non protégé contre l'eau.

**Multi-volt**

Rango de voltaje  
Voltage range

Spannungsbereich  
Campo di tensione  
Gamme de tension  
90-305V



Alternating current  
Corriente alterna  
Wechselstrom  
Corrente alternata  
Courant alternatif  
50/60Hz



Step 2/6

## Supplied Materials

Supplied material / Material suministrado / Geliefertes Material  
Materiale incluso / Matériel fourni

1. Ceiling rose / Florón / Deckenteller / Rosone a soffitto / Pavillon	1 un.
2. Components Bag / Bolsa componentes / Tütchen mit Teilen / Sacchetto componenti / Sachet d'accessoires	1 un.
3. Lighting fixture / Estructura luminaria / Leuchtenstruktur / Struttura lampada / Structure du luminaire	1 un.
4. Template marking tool / Util de marcaje / Markierungshilfe / Utensile di marcatura / Outil de marquage	1 un.

1

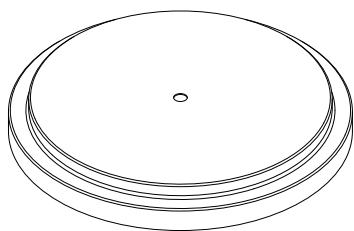

2

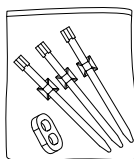

3

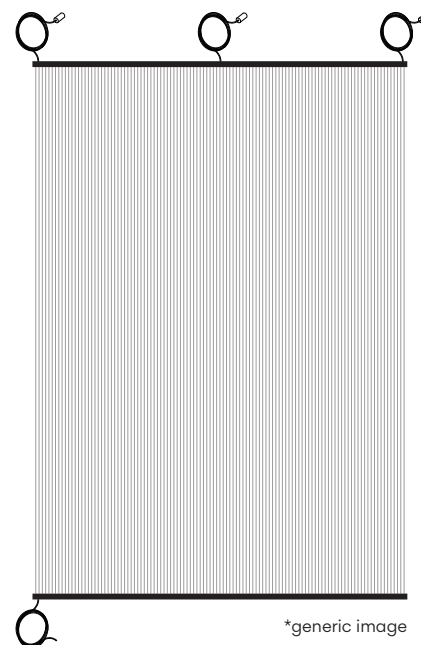

4

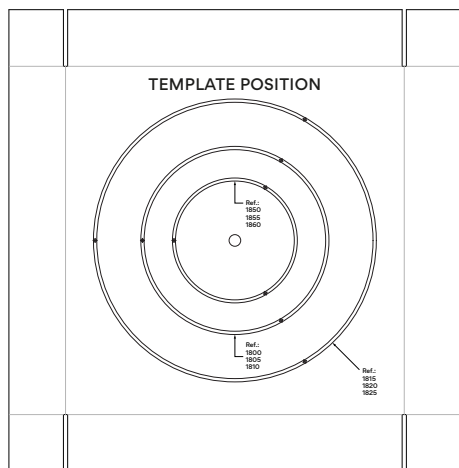

- Marking tool only necessary for the following models:
- Útil de marcaje solo necesario para los siguientes modelos:
- Markierungswerkzeug nur für folgende Modelle notwendig:
- Utensile di marcatura necessario solo per i seguenti modelli:
- Outil de marquage nécessaire uniquement pour les modèles suivants :

1800 1815 1830 1845  
1805 1820 1835 1875  
1810 1825 1840 1880



## Step 3/6 Installation Preparation

3.1

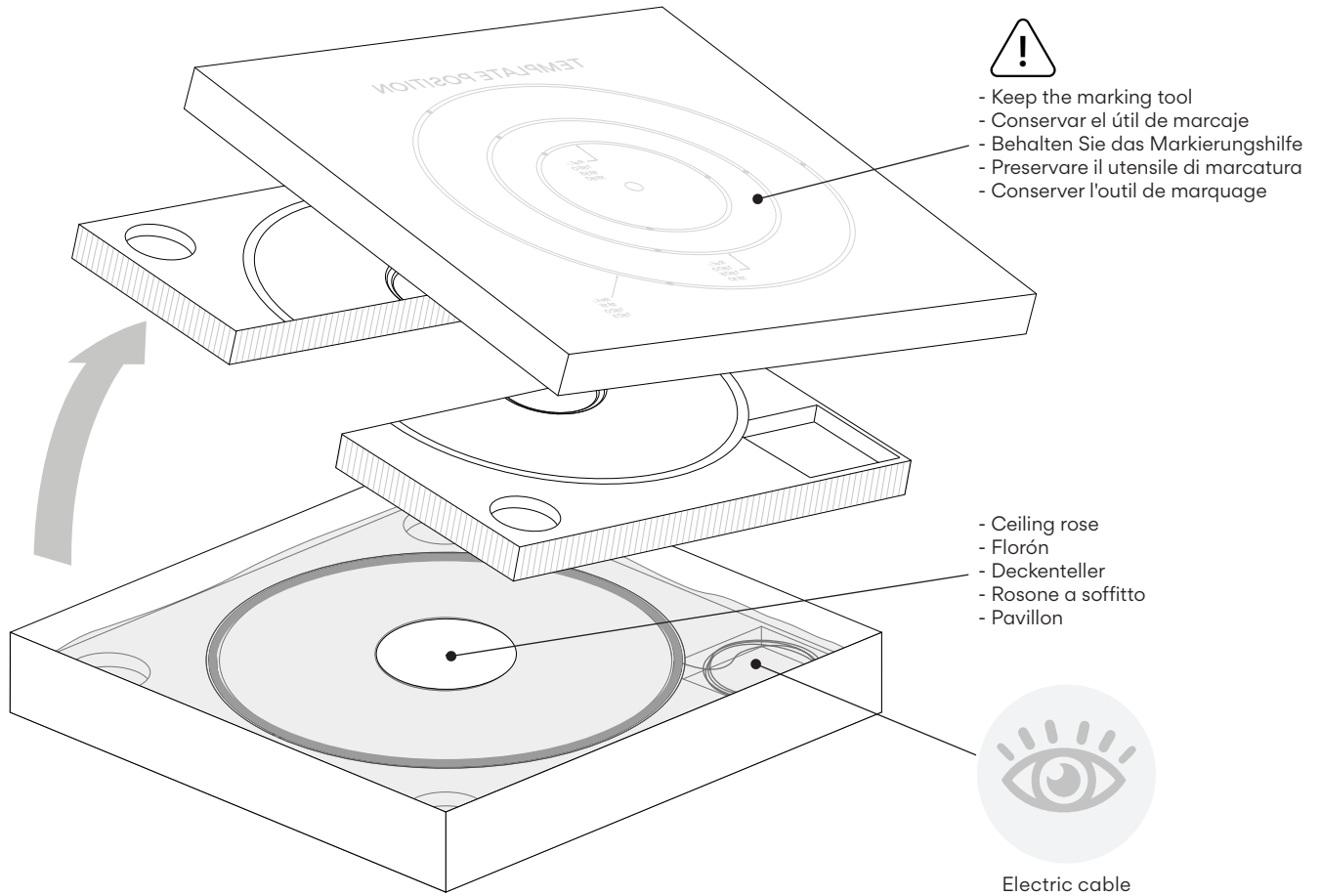

3.2

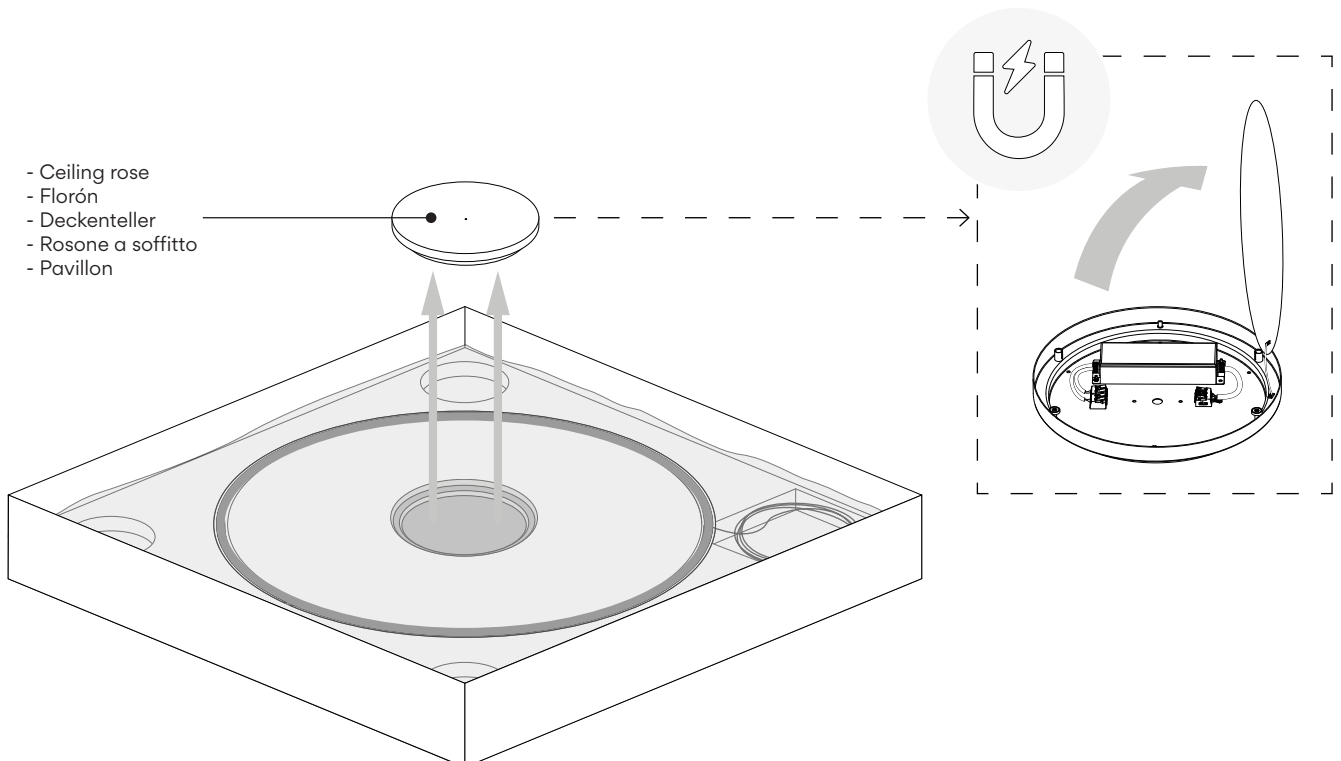





## Step 3/6 Installation Preparation

### 3.3

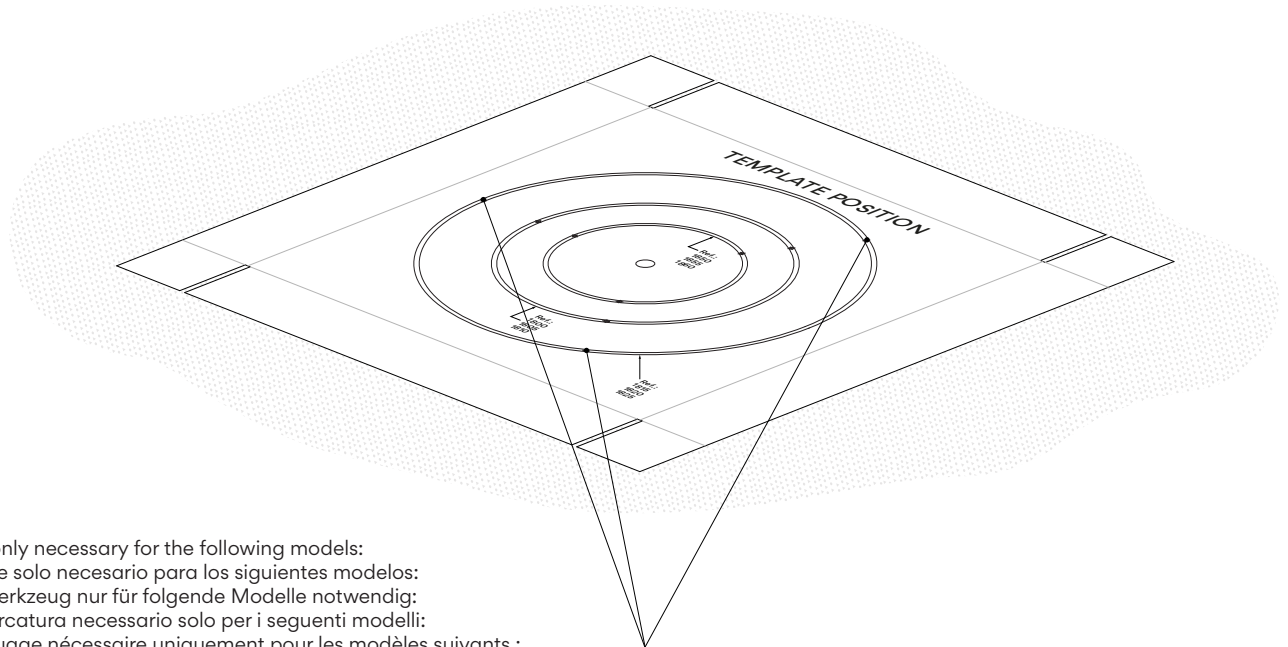

- Marking tool only necessary for the following models:
- Útil de marcaje solo necesario para los siguientes modelos:
- Markierungswerkzeug nur für folgende Modelle notwendig:
- Utensile di marcatura necessario solo per i seguenti modelli:
- Outil de marquage nécessaire uniquement pour les modèles suivants :

1800	1815	1830	1845
1805	1820	1835	1875
1810	1825	1840	1880

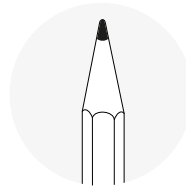

- Mark ceiling
- Marcar techo
- Decke markieren
- Segnare il soffitto
- Marquer le plafond

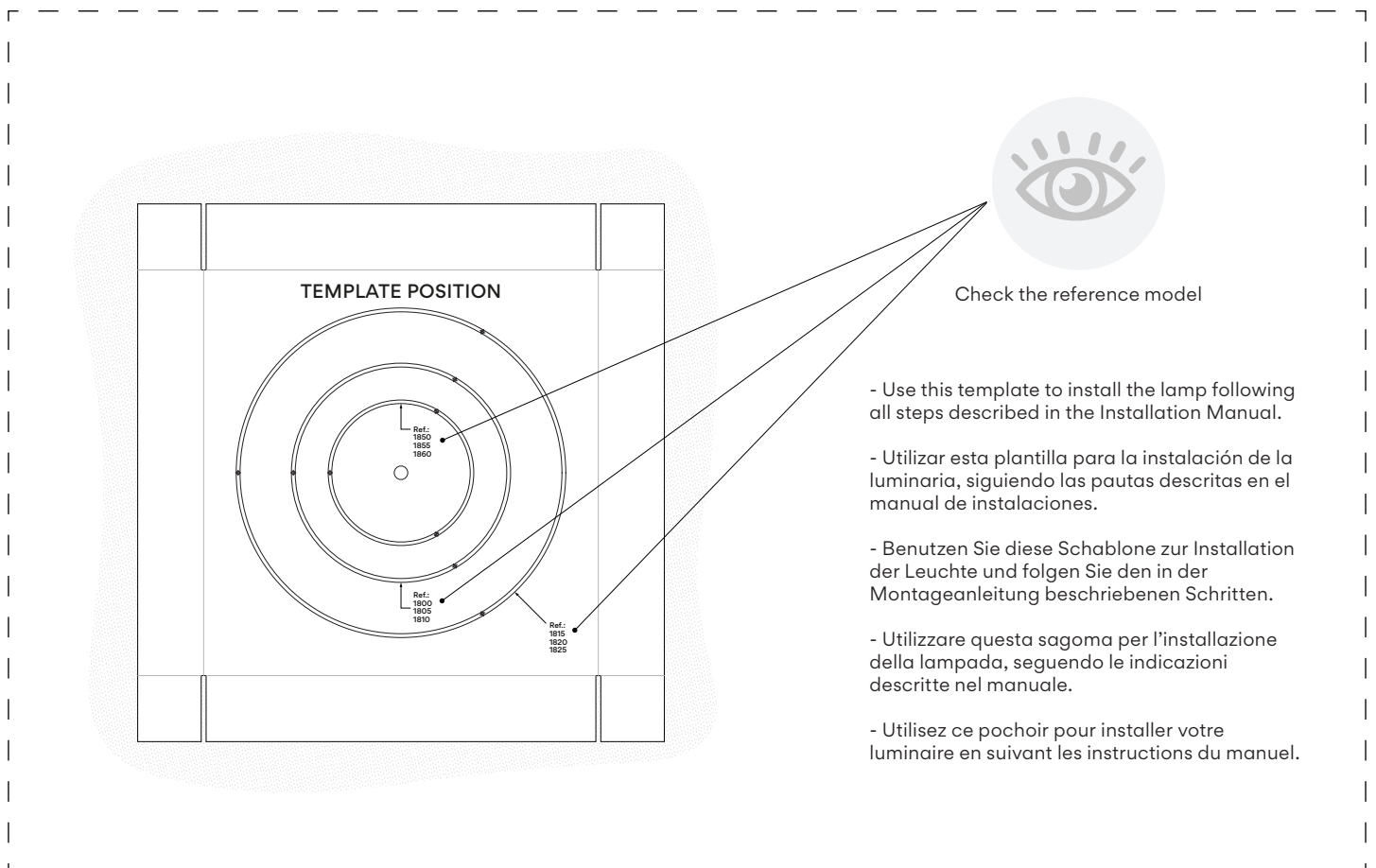

Check the reference model

- Use this template to install the lamp following all steps described in the Installation Manual.

- Utilizar esta plantilla para la instalación de la luminaria, siguiendo las pautas descritas en el manual de instalaciones.

- Benutzen Sie diese Schablone zur Installation der Leuchte und folgen Sie den in der Montageanleitung beschriebenen Schritten.

- Utilizzare questa sagoma per l'installazione della lampada, seguendo le indicazioni descritte nel manuale.

- Utilisez ce pochoir pour installer votre luminaire en suivant les instructions du manuel.



## Step 3/6 Installation Preparation

### 3.4

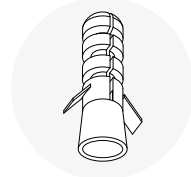
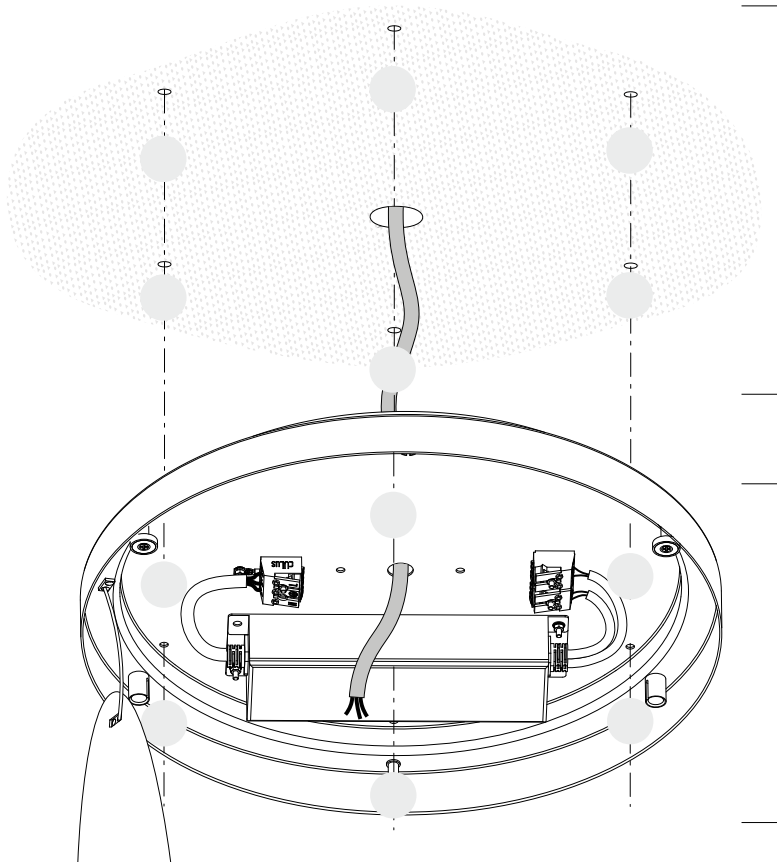

- Wall plugs (not supplied)
- Tacos de fijación (no suministrados)
- Dübel (nicht im Lieferumfang)
- Tasselli di fissaggio (non inclusi)
- Chevilles de fixation (non fournies)

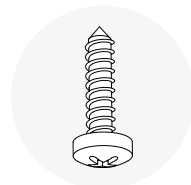

- Screws (not supplied)
- Tornillos (no suministrados)
- Schrauben (nicht im Lieferumfang)
- Viti (non incluse)
- Vis (non fournies)

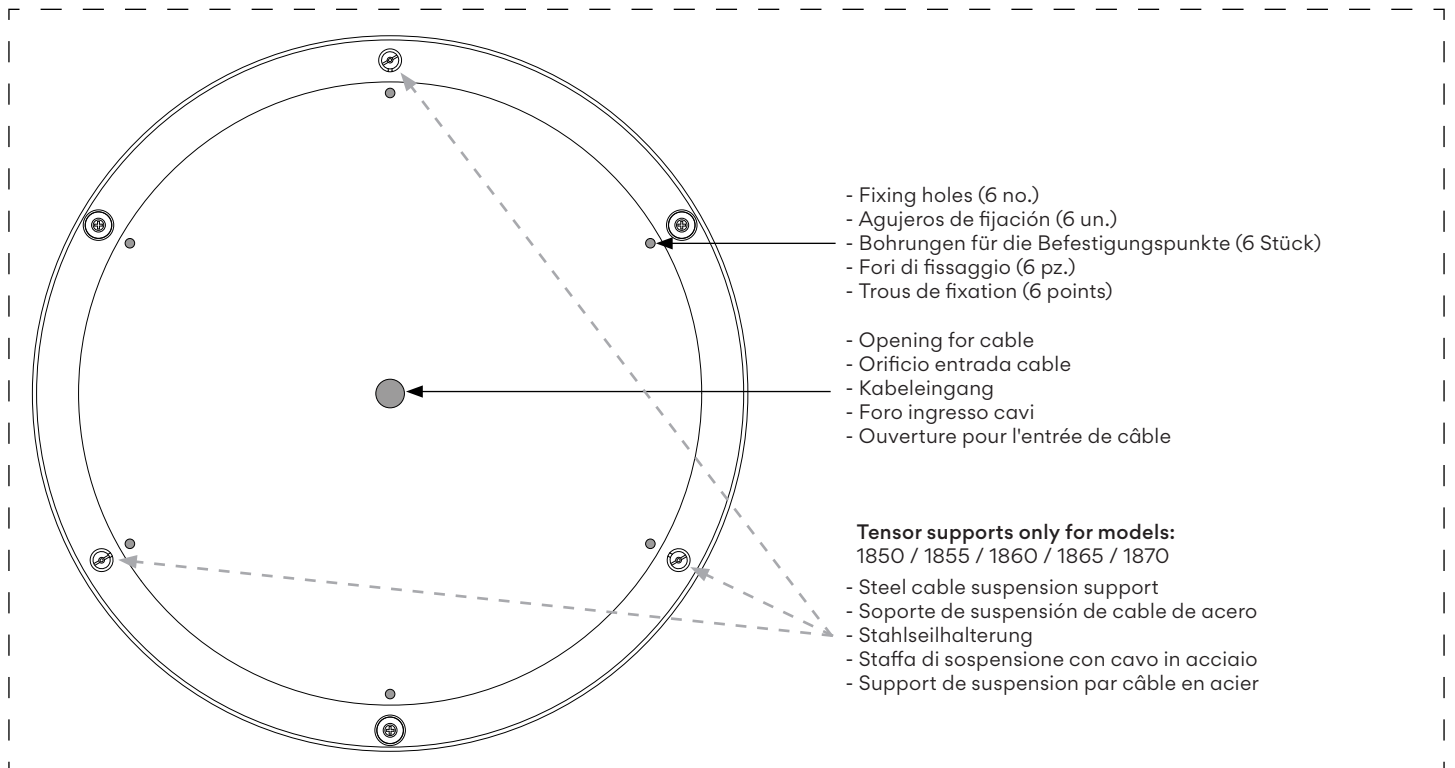

- Fixing holes (6 no.)
- Agujeros de fijación (6 un.)
- Bohrungen für die Befestigungspunkte (6 Stück)
- Fori di fissaggio (6 pz.)
- Trous de fixation (6 points)

- Opening for cable
- Orificio entrada cable
- Kabeleingang
- Foro ingresso cavi
- Ouverture pour l'entrée de câble

**Tensor supports only for models:**  
1850 / 1855 / 1860 / 1865 / 1870

- Steel cable suspension support
- Soporte de suspensión de cable de acero
- Stahlseilhalterung
- Staffa di sospensione con cavo in acciaio
- Support de suspension par câble en acier



# Step 4/6 Electrical Connection

## 4.1

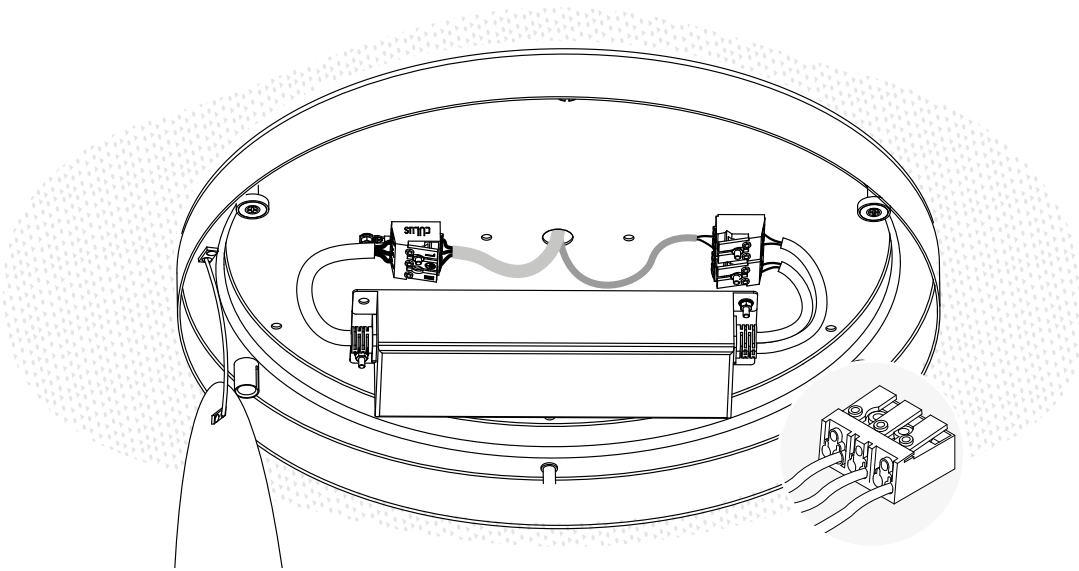

### 1-10V SYSTEM DIMMING

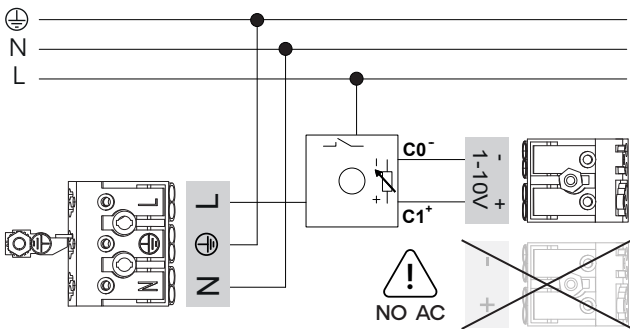

- Refs.:  
18XXXX/13\_10
- Only for product references ending in 3\_10
  - Solo para los productos terminados en 3\_10
  - Nur für Produkte, die auf 3\_10 enden
  - Solo per i prodotti che terminano con 3\_10
  - Uniquement pour les produits terminés en 3\_10

### PUSH SYSTEM DIMMING

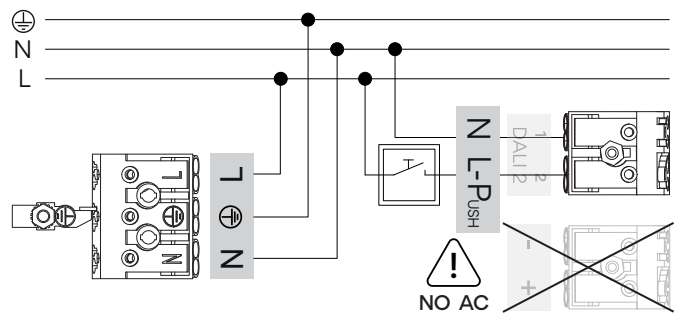

- Refs.:  
18XXXX/1D\_10
- Only for product references ending in D\_10
  - Solo para los productos terminados en D\_10
  - Nur für Produkte, die auf D\_10 enden
  - Solo per i prodotti che terminano con D\_10
  - Uniquement pour les produits terminés en D\_10

### DALI SYSTEM DIMMING

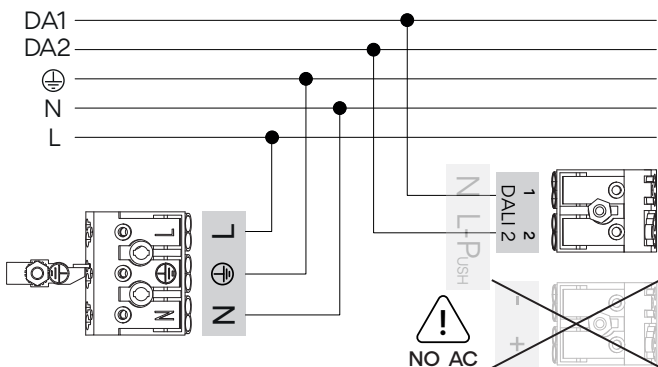

- Refs.:  
18XXXX/1D\_10
- Only for product references ending in D\_10
  - Solo para los productos terminados en D\_10
  - Nur für Produkte, die auf D\_10 enden
  - Solo per i prodotti che terminano con D\_10
  - Uniquement pour les produits terminés en D\_10

### CASAMBI SYSTEM DIMMING

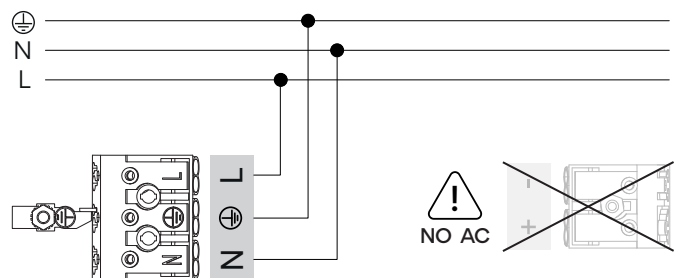

- Refs.:  
18XXXX/1Z\_10
- Only for product references ending in Z\_10
  - Solo para los productos terminados en Z\_10
  - Nur für Produkte, die auf Z\_10 enden
  - Solo per i prodotti che terminano con Z\_10
  - Uniquement pour les produits terminés en Z\_10



# Step 5/6 Product Assembly

5.1

  
Max.: 5 mt.

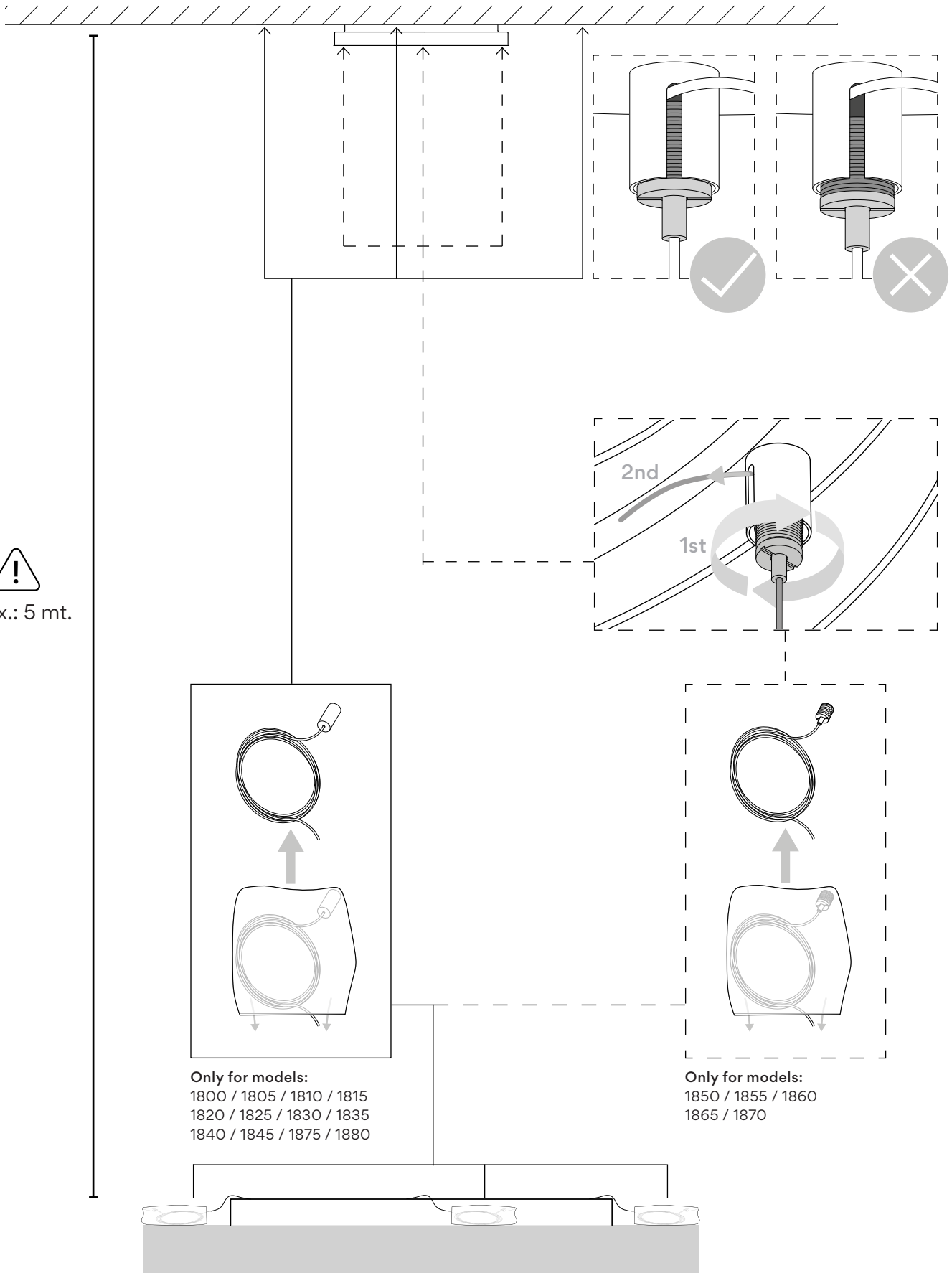



## Step 5/6 Product Assembly

### 5.2

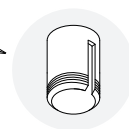
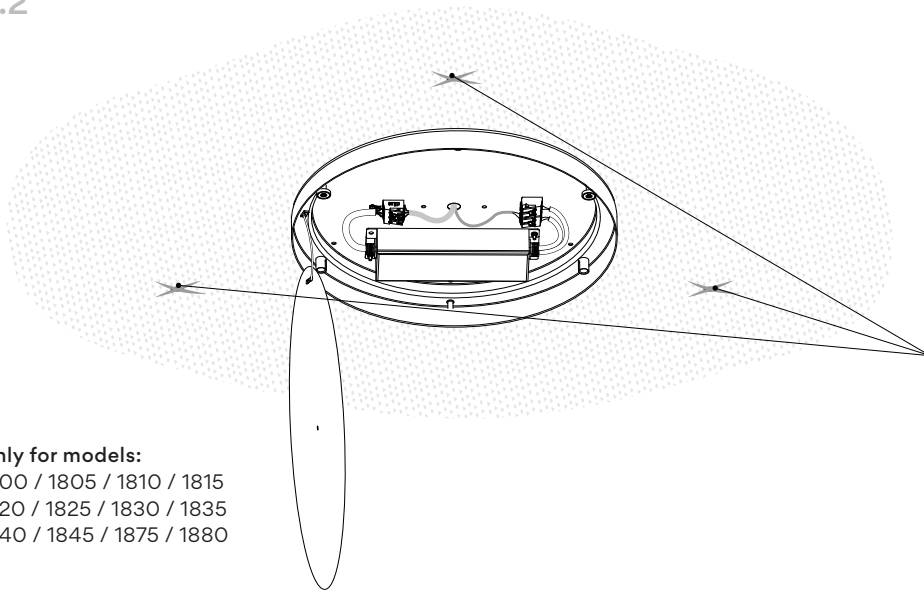

- Wall plugs (not supplied)
- Tacos de fijación (no suministrados)
- Dübel (nicht im Lieferumfang)
- Tasselli di fissaggio (non inclusi)
- Chevilles de fixation (non fournies)

#### Only for models:

1800 / 1805 / 1810 / 1815  
1820 / 1825 / 1830 / 1835  
1840 / 1845 / 1875 / 1880

- Screws (not supplied)
- Tornillos (no suministrados)
- Schrauben (nicht im Lieferumfang)
- Viti (non incluse)
- Vis (non fournies)

### 5.3

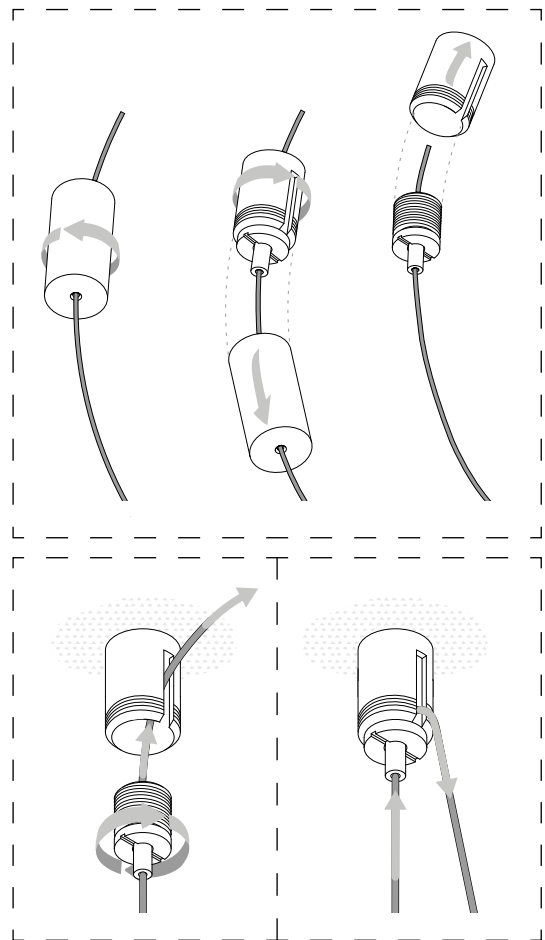

 Tensor cable length = 10 mt.



## Step 5/6 Product Assembly

### 5.4

Only for models:

1800 / 1805 / 1810 / 1815  
1820 / 1825 / 1830 / 1835  
1840 / 1845 / 1875 / 1880

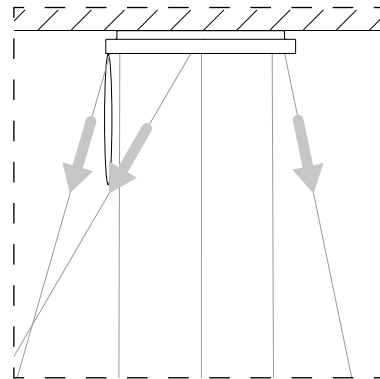
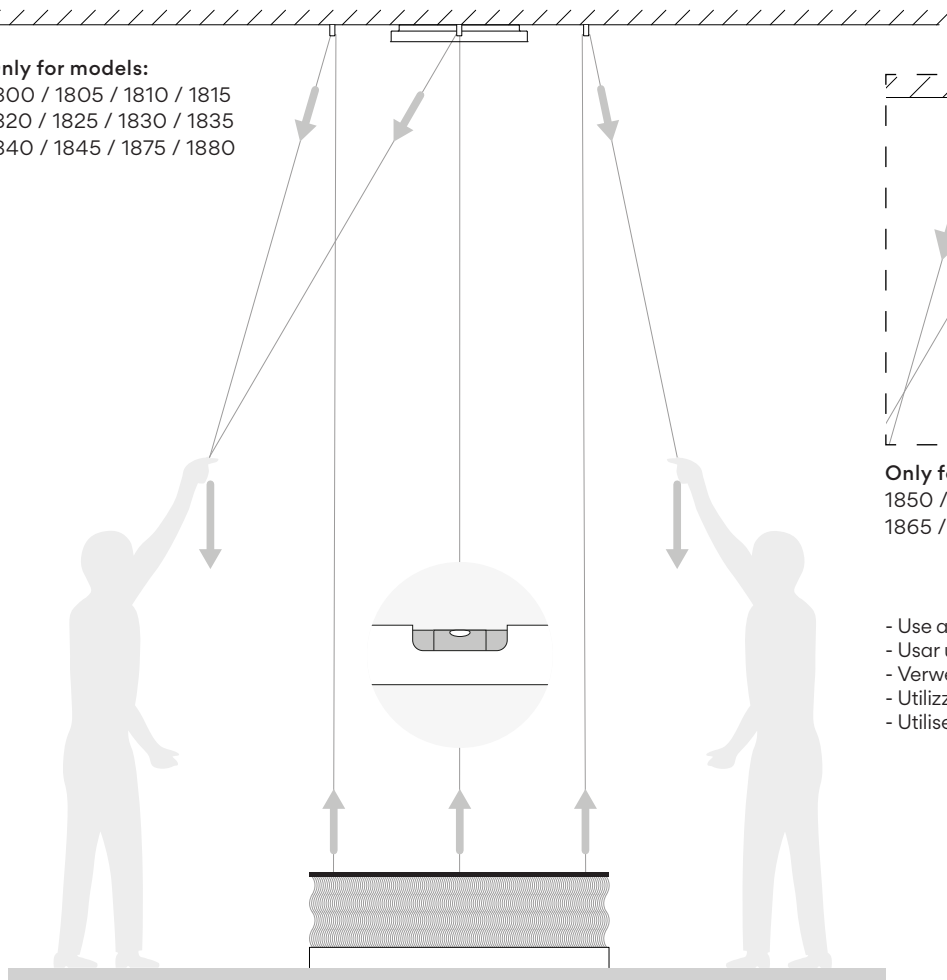

Only for models:

1850 / 1855 / 1860  
1865 / 1870

- Use a spirit level (not supplied)
- Usar un nivel (no suministrados)
- Verwenden Wasserwaage (nicht im Lieferumfang)
- Utilizzare una livella a bolla (non inclusi)
- Utiliser un niveau à bulle (non fournies)

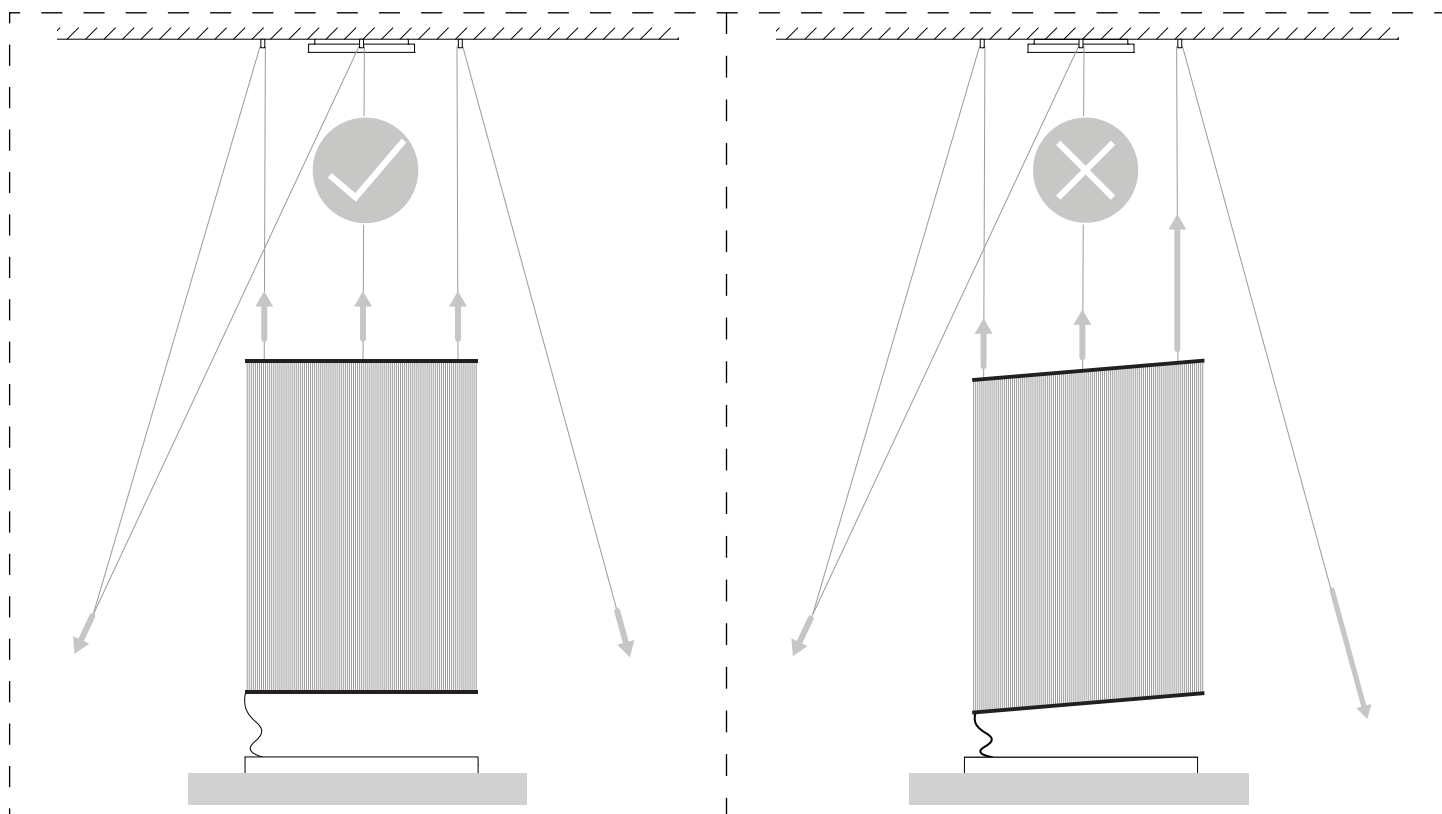



# Step 5/6 Product Assembly

5.5

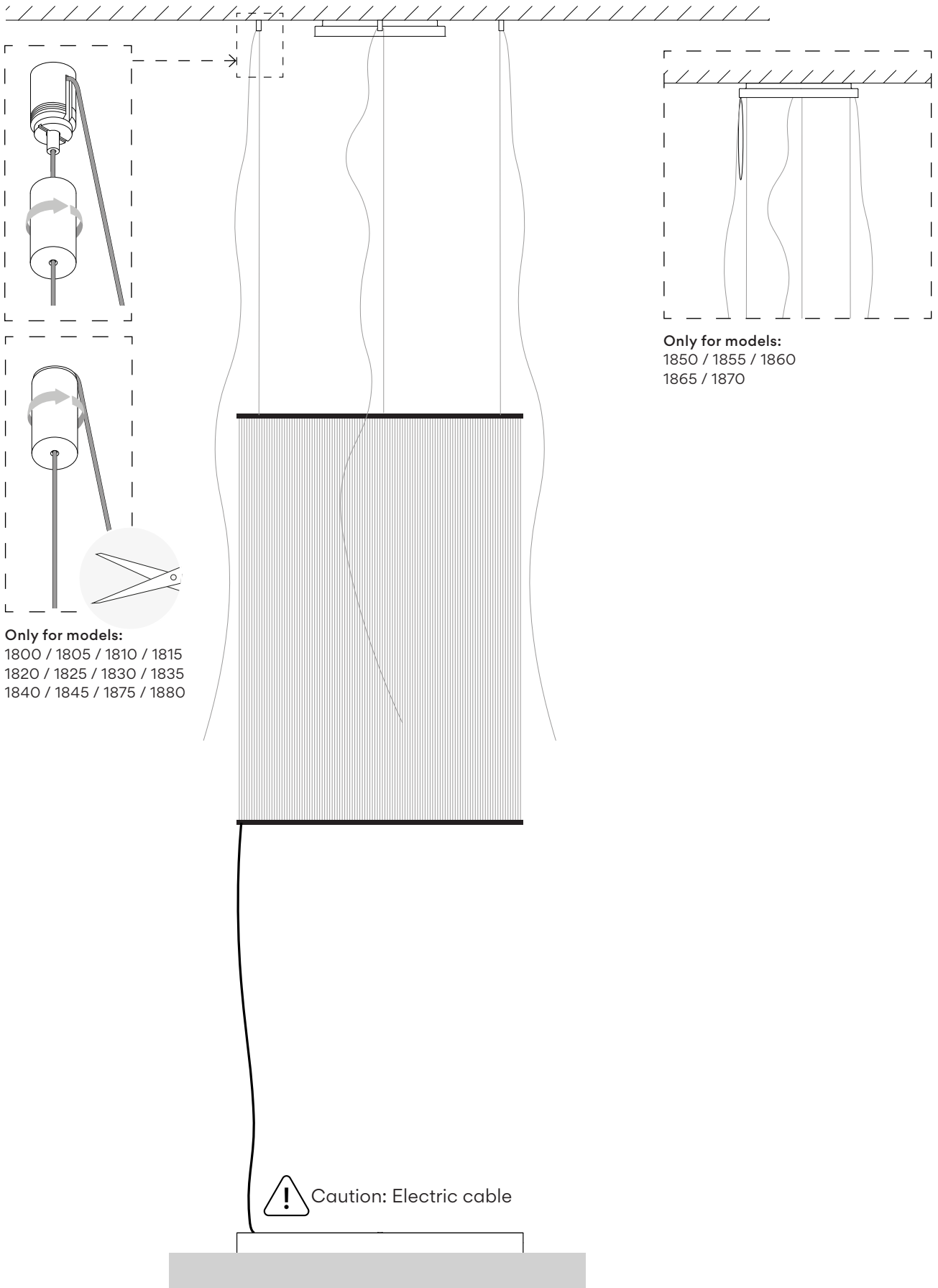

**Only for models:**  
1800 / 1805 / 1810 / 1815  
1820 / 1825 / 1830 / 1835  
1840 / 1845 / 1875 / 1880

**Only for models:**  
1850 / 1855 / 1860  
1865 / 1870

 Caution: Electric cable



Step 5/6  
Product Assembly

5.6

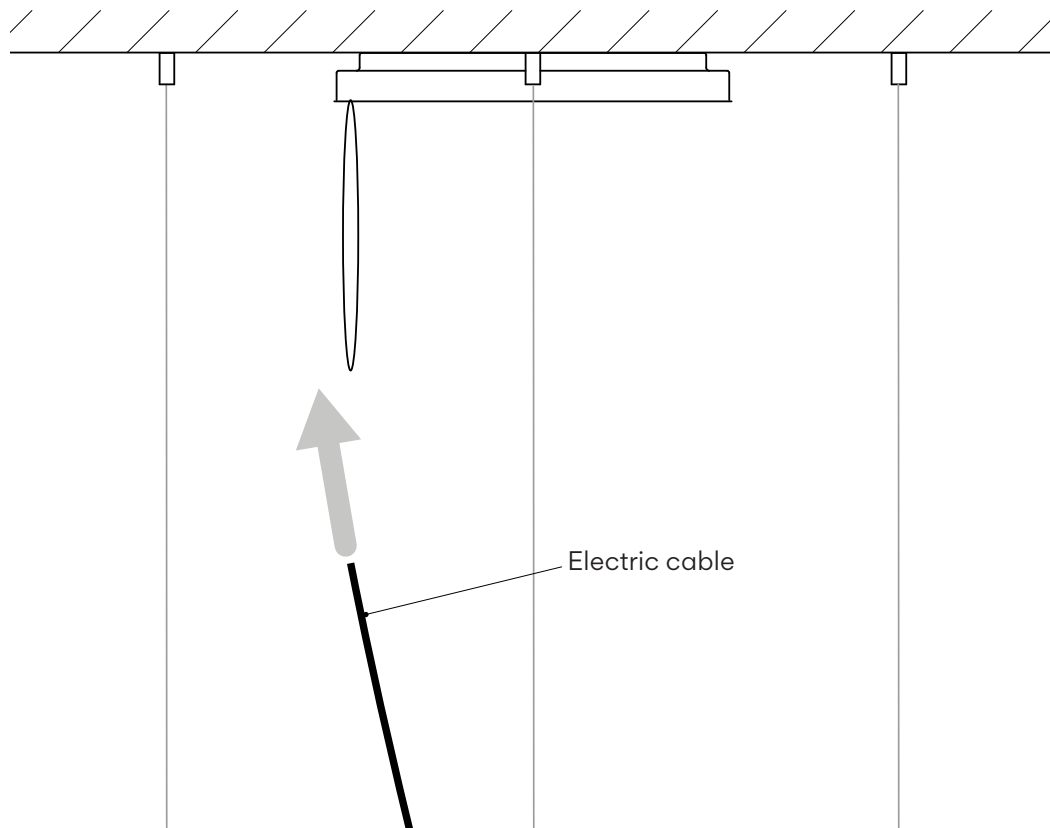

5.7

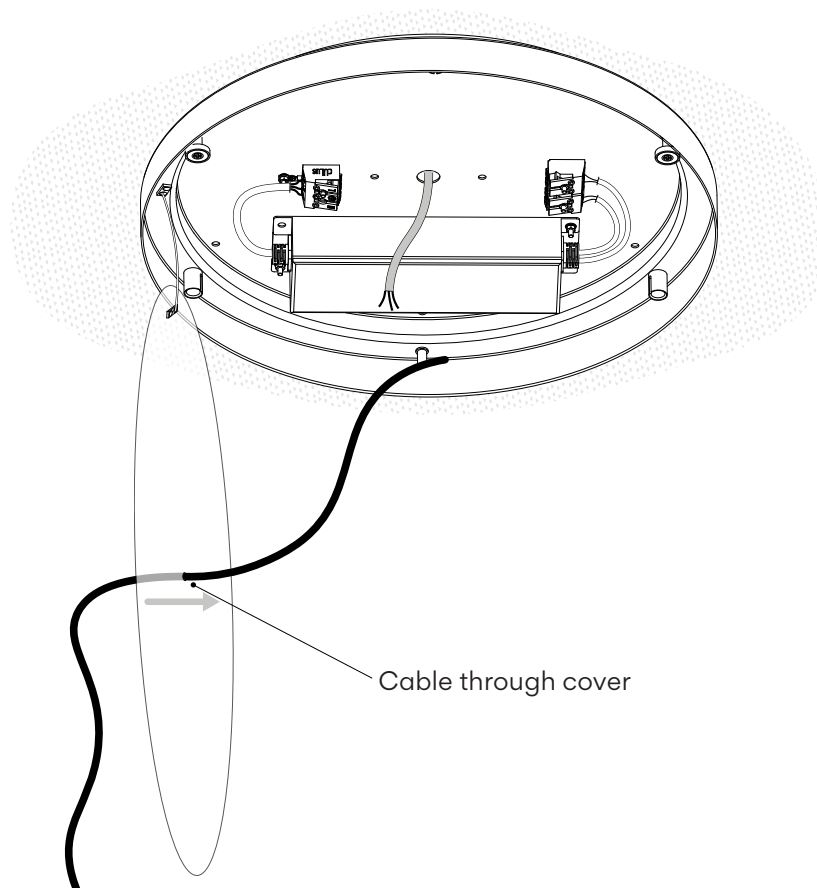





# Step 5/6 Product Assembly

5.8

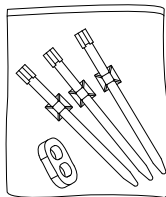

- Components Bag
- Bolsa de componentes
- Tütchen mit Teilen
- Sacchetto componenti
- Sachet d'accessoires

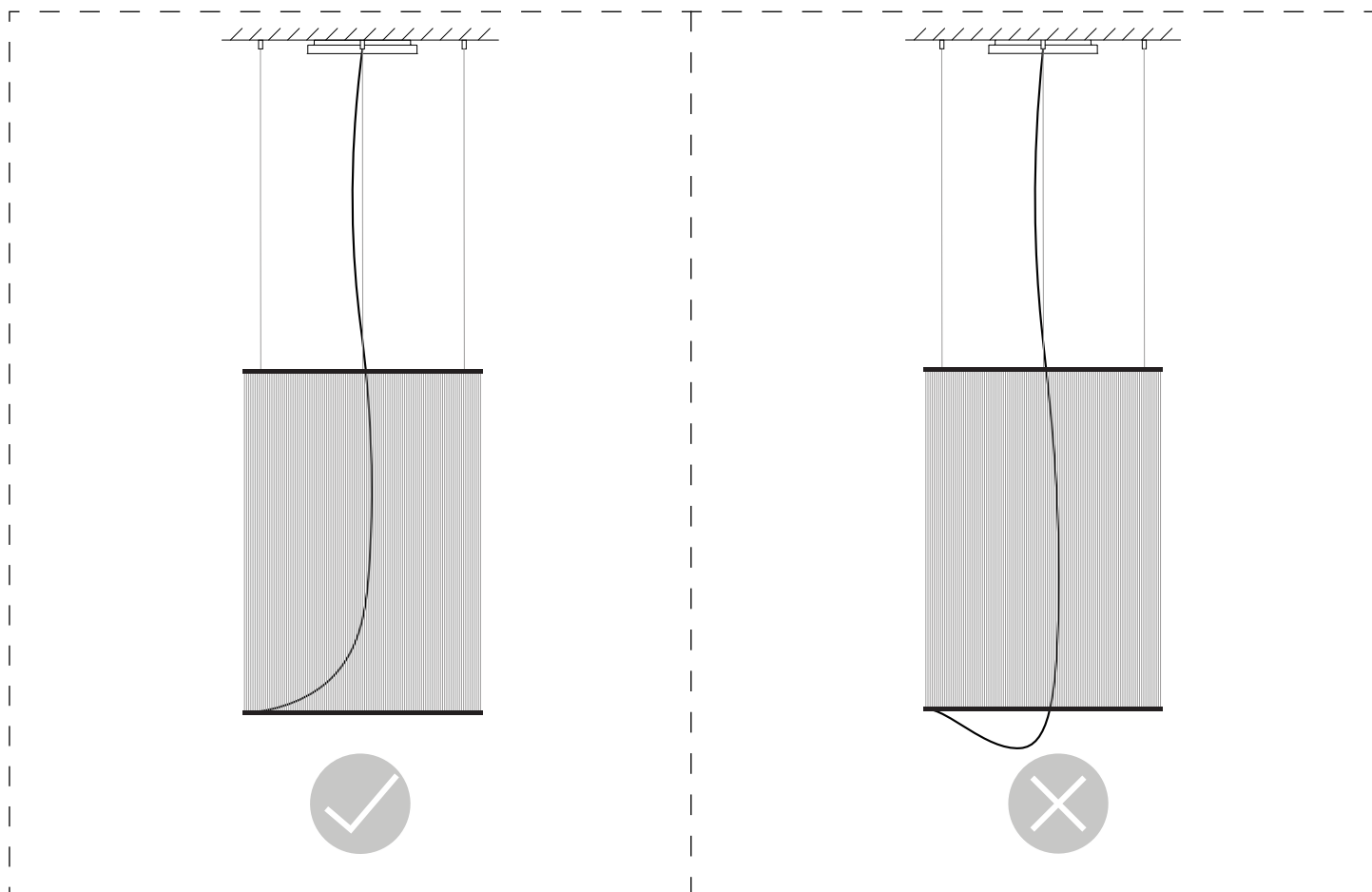
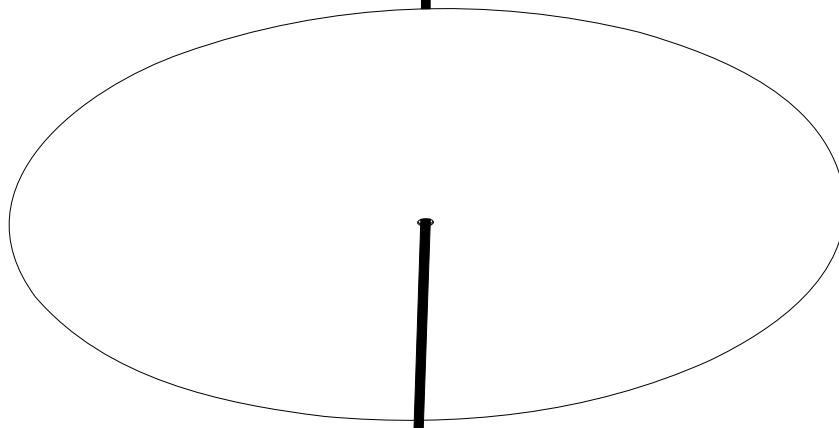
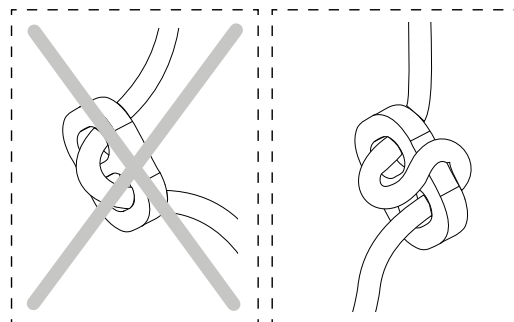



## Step 5/6 Product Assembly

5.9

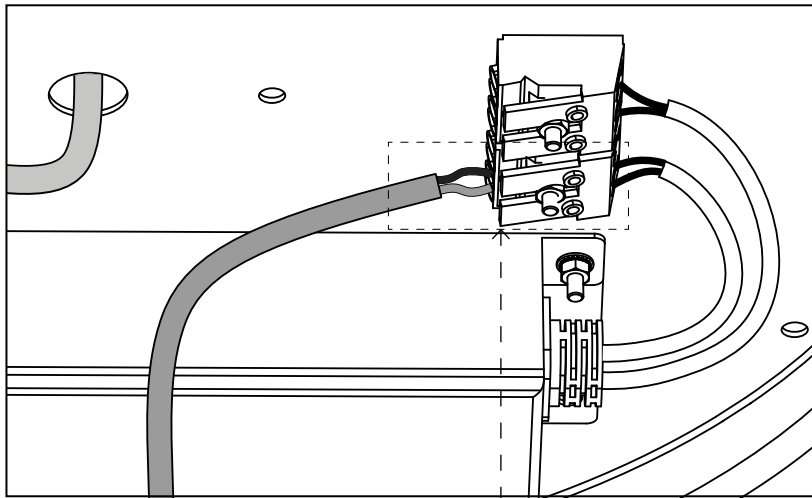

-VERY IMPORTANT: Make sure before making the connection that the power supply to your installation is disconnected.

-MUY IMPORTANTE: Asegurarse antes de efectuar la conexión que este cortado el suministro eléctrico de su instalación.

-SEHR WICHTIG: Stellen Sie sicher, dass vor Anschluss die elektrische Spannungsversorgung getrennt wurde.

-MOLTO IMPORTANTE: Prima di effettuare il collegamento, assicurarsi che l'alimentazione elettrica dell'impianto sia spenta.

-TRÈS IMPORTANT: Assurez-vous que le courant électrique de votre installation est coupé avant de connecter.

CAUTION POLARITY

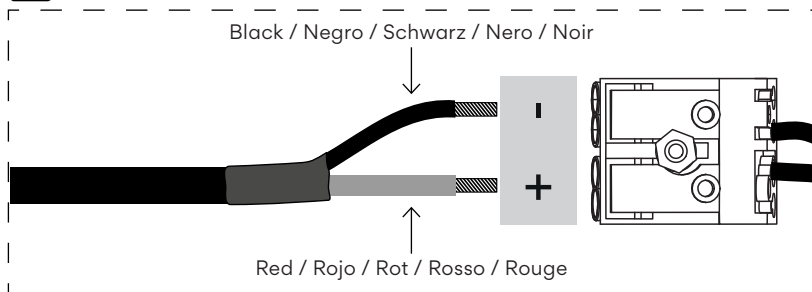

5.10

Closing the canopy

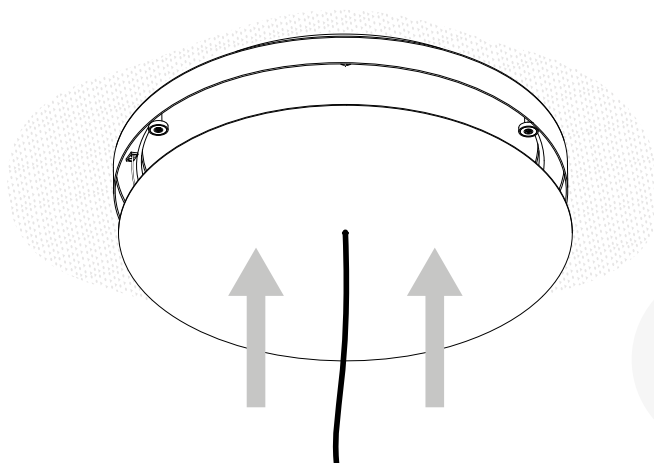

For models:  
1800 / 1805 / 1810 / 1815  
1820 / 1825 / 1830 / 1835  
1840 / 1845 / 1875 / 1880

Closing the canopy

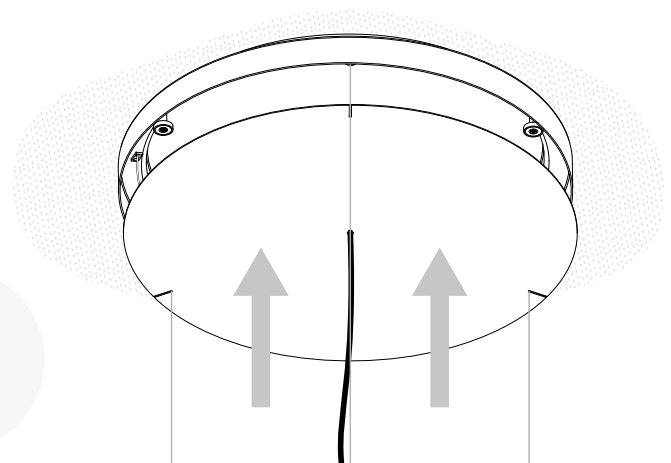

For models:  
1850 / 1855 / 1860  
1865 / 1870



## Step 6/6

# Adjustments & Maintenance

Modify the height of the light / Modificar la altura de la luminaria / Um die Höhe der Leuchte zu ändern / Modificare l'altezza della lampada / Régler la hauteur du luminaire

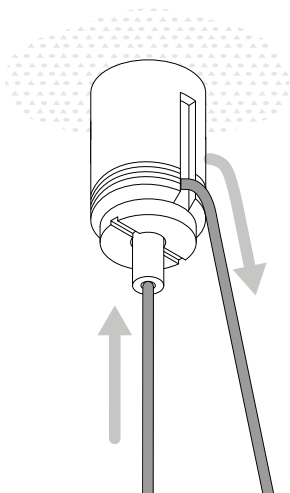

**For models:**

1800 / 1805 / 1810 / 1815

1820 / 1825 / 1830 / 1835

1840 / 1845 / 1875 / 1880

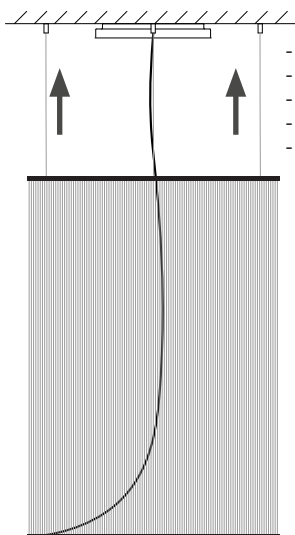

- To raise
- Para subir
- Zum höherstellen
- Per alzare
- Monter

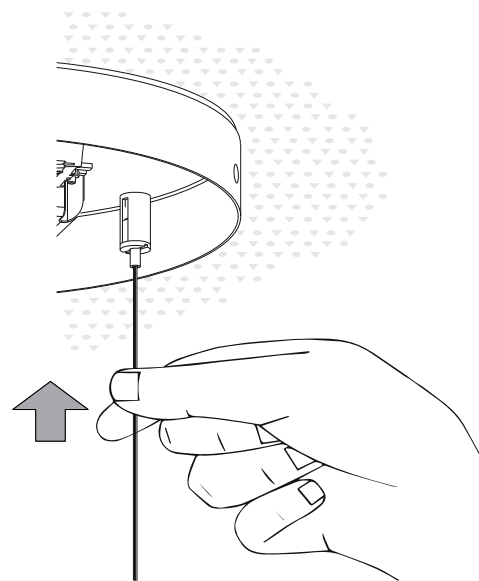

**For models:**

1850 / 1855 / 1860

1865 / 1870

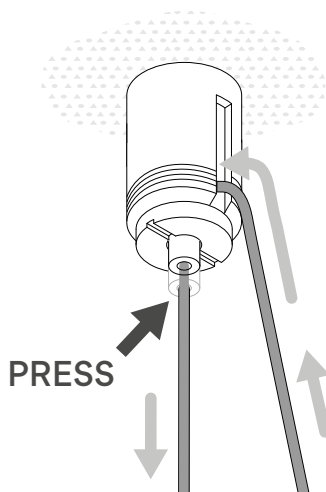

**For models:**

1800 / 1805 / 1810 / 1815

1820 / 1825 / 1830 / 1835

1840 / 1845 / 1875 / 1880

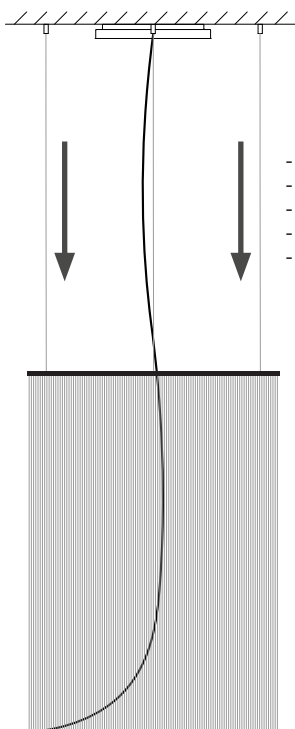

- To lower
- Para bajar
- Zum niedrigerstellen
- Per abbassare
- Descendre

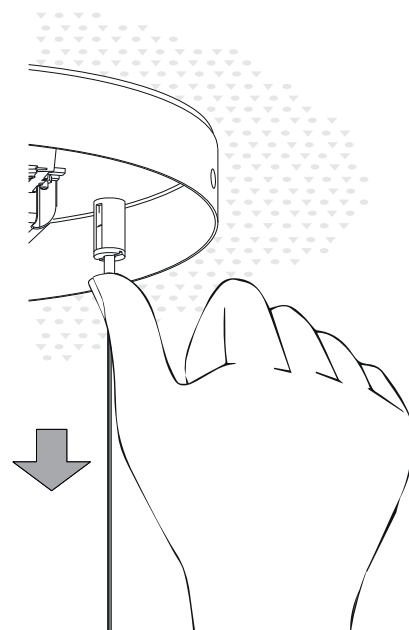

**For models:**

1850 / 1855 / 1860

1865 / 1870



Step 6/6

## Adjustments & Maintenance

Modify the cable length / Modificar la longitud del cable / Kabellänge ändern  
Modificare la lunghezza del cavo / Modifier la longueur du câble

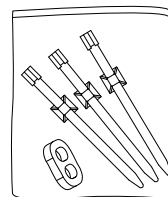
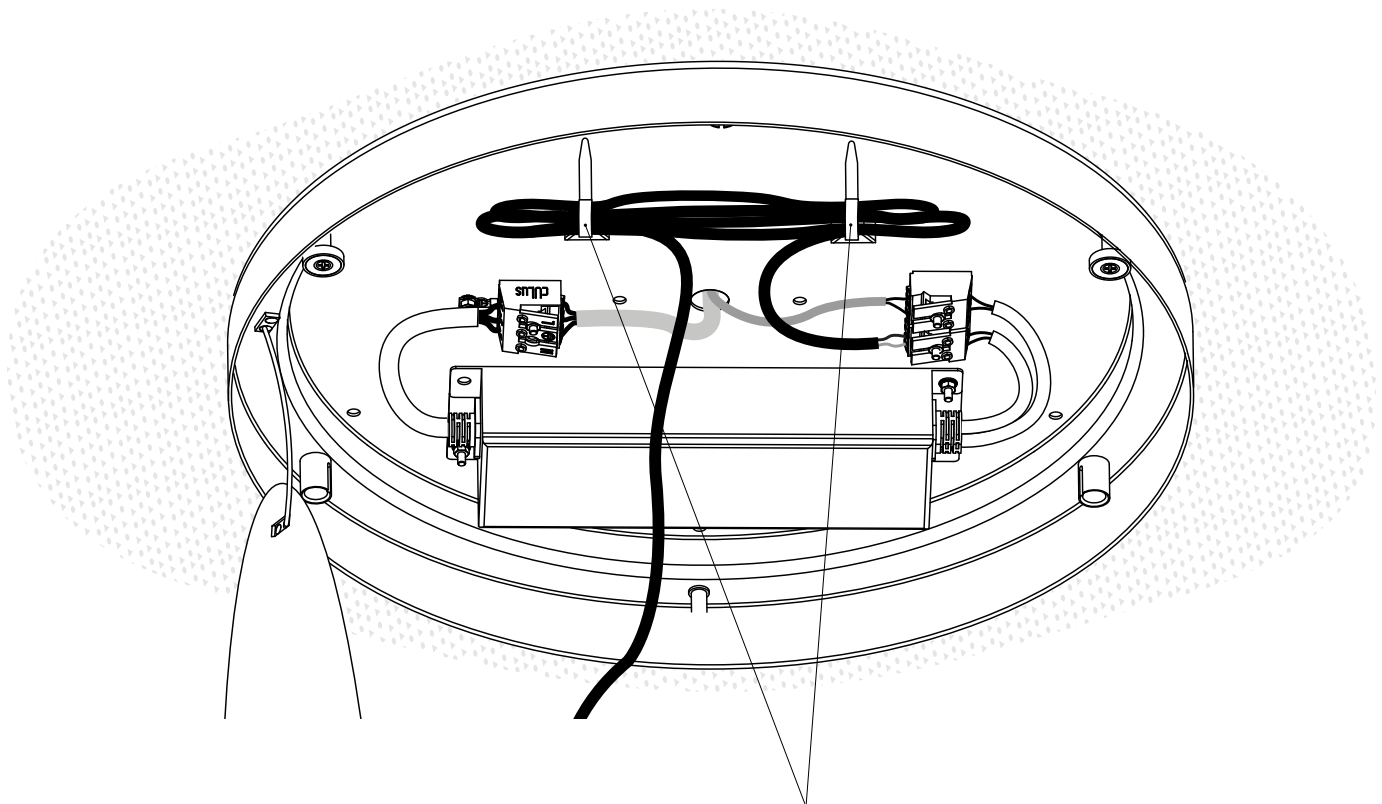

- Components Bag
- Bolsa de componentes
- Tütchen mit Teilen
- Sacchetto componenti
- Sachet d'accessoires

## Maintenance

Use a slightly-wet cotton cloth for cleaning.

In case of malfunction or damage, please contact the retailer who sold the lamp.

## Mantenimiento

Para limpiar la luminaria, usar un paño de algodón ligeramente humedecido en agua.

En caso de avería o incidente con la luminaria, contactar directamente con el establecimiento en que se adquirió.

## Instandhaltung

Zur Reinigung der Leuchte nutzen Sie einen leicht angefeuchteten Baumwoll-Lappen.

Im Falle des Ausfalls oder einer Fehlfunktion der Leuchte setzen Sie sich direkt mit dem Unternehmen in Verbindung bei dem Sie die Leuchte bezogen haben.

## Manutenzione

Per la pulizia della lampada, usare un panno di cotone leggermente inumidito con acqua.

In caso di guasto o incidente con la lampada, rivolgersi direttamente al rivenditore da cui è stata acquistata.

## Entretien

Pour nettoyer le luminaire, utilisez un chiffon en coton légèrement humidifié d'eau.

En cas d'incident ou de défaillance du luminaire, contactez directement l'établissement où vous l'avez acheté. the retailer who sold the lamp.

Vibia Lighting, S.L.U.

Progrés 4-6.

08850 Gavà (Barcelona)

Spain & Portugal T. +34 934 796 970

International T. +34 934 796 971

customer.service@vibia.com

www.vibia.com

VIBIA