

TAIO ceiling

INSTALLATION INSTRUCTIONS | DECEMBER 2022

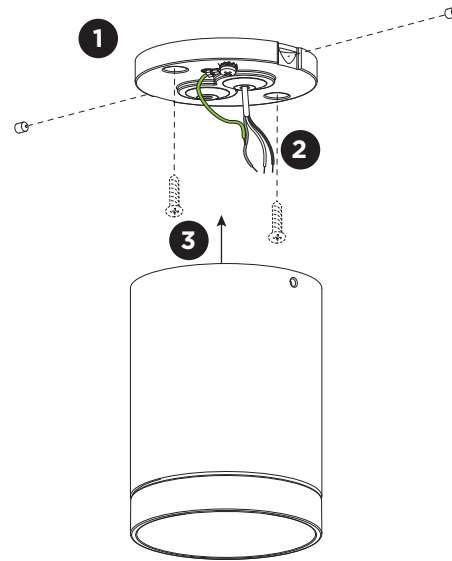

DIMENSIONS

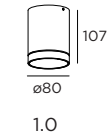

MOUNTING INSTRUCTION

- 1 Remove the mounting base from the luminaire by loosening the socket screws and mount it on the ceiling with screws.

- 2 **POWER CONNECTION**

Connect to 220-240V.

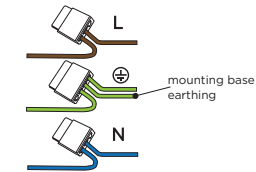





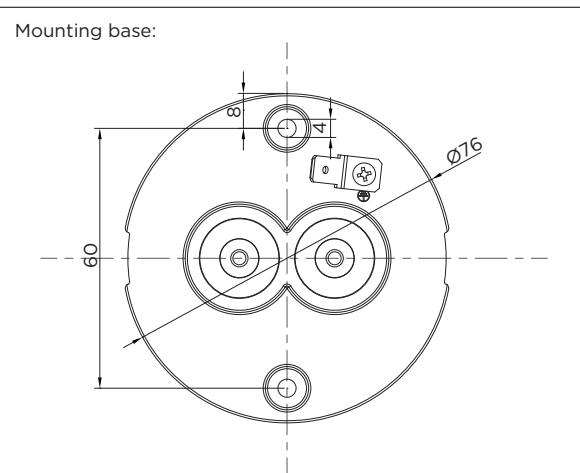

Connect the earth cable.



- 3 Fixate the luminaire on the base with the socket screws.



Please use a matching grommet based on the used 220-240V cable and the corresponding type in the overview table.

	A	B	C
 use pin to make hole, not a knife			
CABLE			
TYPE	ROUND H05RN-F H07RN8-F H07RN-F	ROUND H05RN-F	ROUND
OUTSIDE Ø	min 6.8mm max 8.9mm	min 5mm max 6.8mm	min 1.5mm max 2.6mm
CONDUCTION SECTION	2or3x 0.75mm ² 2or3x 1.0mm ² 2or3x 1.5mm ²	2or3x 0.75mm ² 2x 1.0mm ²	0.75mm ² 1.5mm ²

TAIO ceiling

INSTALLATION INSTRUCTIONS | DECEMBER 2022

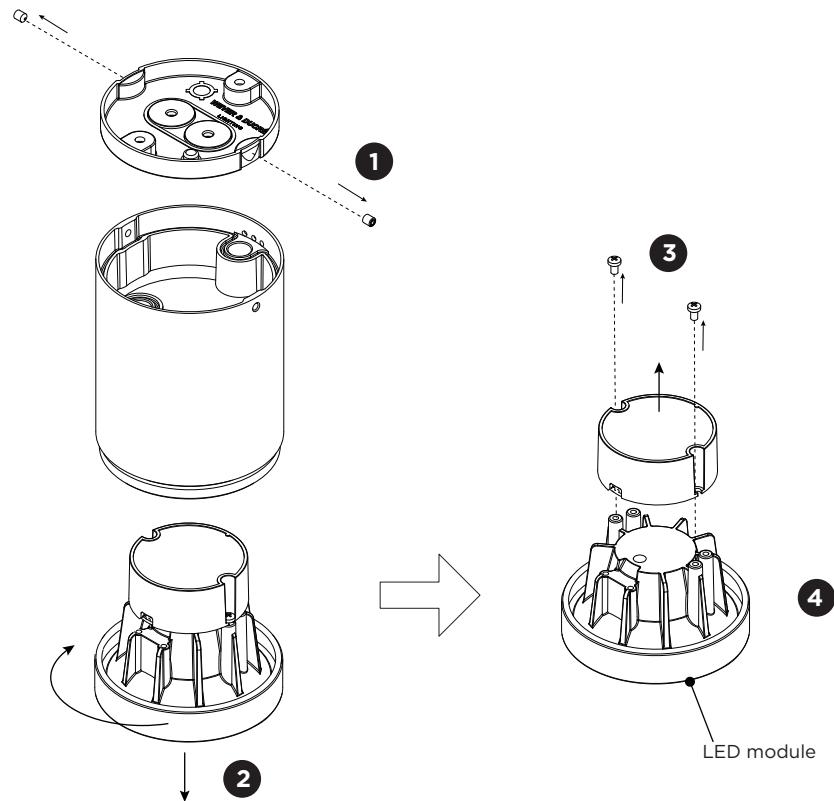

DISMOUNTING AND RECYCLING INSTRUCTIONS

Light source & driver

- 1 Loosen the side screws and remove the lamphousing from the mounting base.
- 2 Disconnect the wires of the power and turn out the light body together with the driver.
- 3 Loosen the screws and the driver can now be removed.
- 4 The LED Module can be removed and replaced.

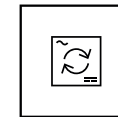

The driver can be replaced by the end user.

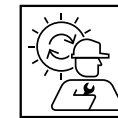

The light source is replaceable by an authorized professional.
For advice contact your Wever & Ducré customer service contact point.



This luminaire contains a light source with the energy class D.