

Pantop Portable

Design by VERNER PANTON

Please read thoroughly before use

1

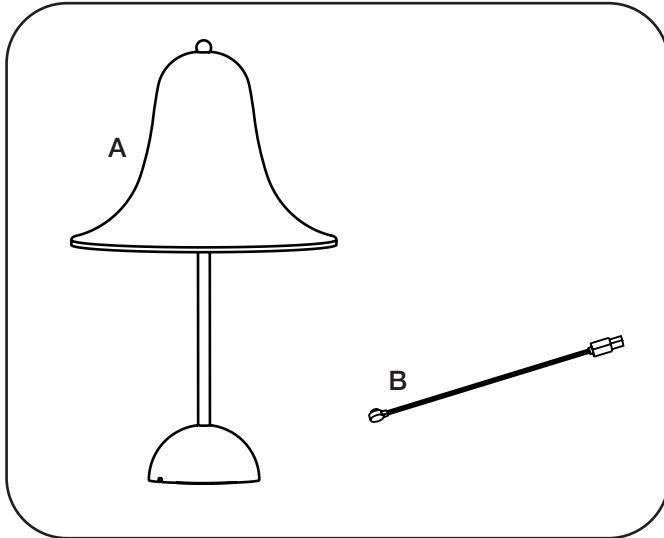

CONTENT:

A PANTON TABLE LAMP. THE LAMP IS DELIVERED FULLY ASSEMBLED.

B USB CHARGING CABLE

2

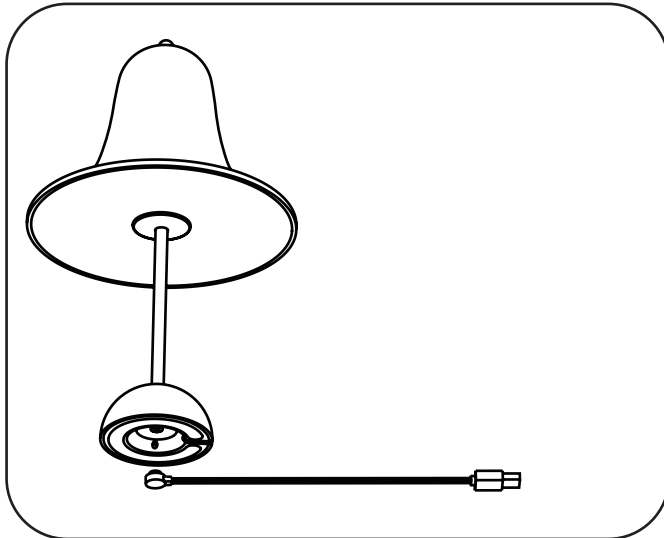

BEFORE USE, THE BATTERY IN THE LAMP MUST BE FULLY CHARGED.

PLACE THE MAGNETIC CHARGING CABLE AT THE BOTTOM OF THE LAMP. CONNECT THE USB CABLE TO A POWER SUPPLY.

3

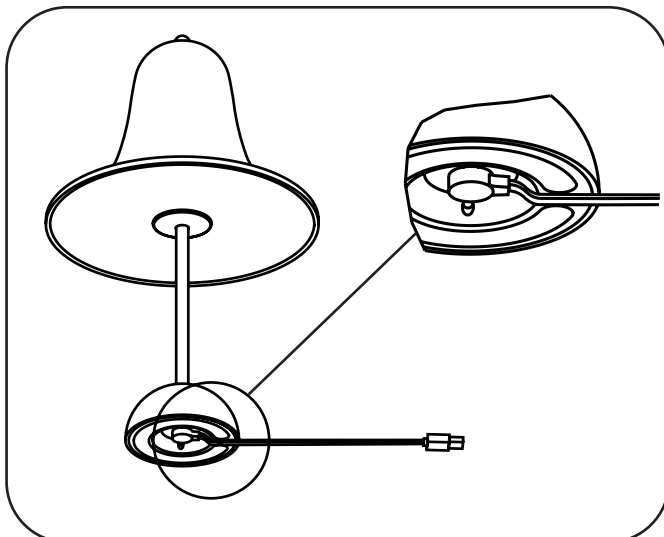

CHARGING: RED LIGHT

FULLY CHARGED: GREEN LIGHT

4

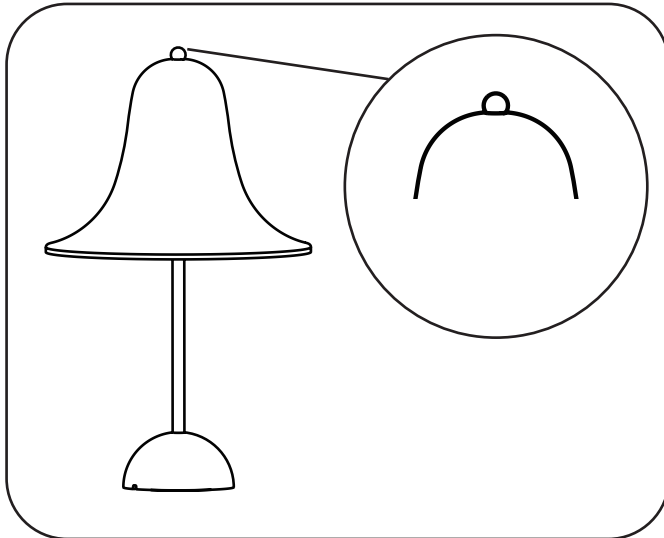

THE LIGHT INTENSITY OF THE LAMP CAN BE ADJUSTED BY TOUCHING THE DIMMER KNOB ON THE TOP OF THE LAMP.

THE LAMP HAS 3 LIGHT INTENSITY LEVELS: 100%, 70% AND 30%.

IMPORTANT:

- THIS LAMP IS FOR INDOORS USE ONLY. IT CAN BE TAKEN OUTDOORS, BUT MUST BE KEPT AND STORED INDOORS.
- BATTERIES MUST BE DISPOSED OF ACCORDING TO LOCAL ENVIRONMENTAL LAWS FOR WASTE DISPOSAL.
- WIPE THE SURFACE WITH A SOFT, DAMP CLOTH, AND WIPE IMMEDIATELY WITH A DRY CLOTH. DO NOT USE ANY ABRASIVE CLEANING TOOLS.
- THE BATTERY MUST BE REMOVED FROM THE LAMP BEFORE IT IS SCRAPPED; THE APPLIANCE MUST BE DISCONNECTED FROM THE SUPPLY MAINS WHEN REMOVING THE BATTERY; THE BATTERY MUST BE DISPOSED SAFELY.
- IF THE EXTERNAL FLEXIBLE CABLE OR CORD OF THIS LUMINAIRE IS DAMAGED, IT SHALL BE REPLACED BY A SPECIAL CORD OR CORD EXCLUSIVELY AVAILABLE FROM THE MANUFACTURER OR HIS SERVICE AGENT.
- THE PRODUCT SHALL BE SUPPLIED BY AN EXTERNAL SELV CONTROLGEAR WITH 5V MIN. 1A OUTPUT.

- INPUT MICRO USB CABLE 5.0 = 1A
- 1.5W LED BOARD
- CHARGING TIME: 5 HOURS
- OPERATION TIME IN HIGHEST SETTING: 7 HOURS

DESIGNED
IN THE PAST
MADE FOR
TOMORROW

VERPAN
Egeskovvej 29
8700 Horsens
Denmark

www.verpan.com

info@verpan.com