

# Occhio

## Più alto doppio Più alto 3d doppio

Montageanleitung  
Mounting instructions

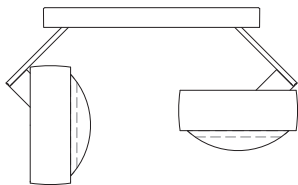
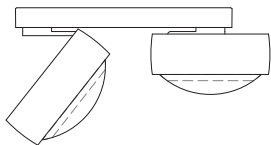

Più alto doppio + Occhio air  
Più alto 3d doppio + Occhio air





# Inhalt / Contents

Sicherheitshinweise	04	Safety precautions	05
Produktbeschreibung	06	Product description	07
<b>Montage head</b>	<b>09</b>	<b>Assembling the head</b>	<b>09</b>
<b>Montage Più doppio</b>	<b>19</b>	<b>Mounting Più doppio</b>	<b>19</b>
<b>Montage Più doppio + »air« module (optional)</b>	<b>22</b>	<b>Mounting Più doppio + »air« module (optional)</b>	<b>22</b>
<b>Demontage Più doppio</b>	<b>35</b>	<b>Removing Più doppio</b>	<b>35</b>
<b>Steuerung mit der »air« App (optional)</b>	<b>39</b>	<b>Control with the »air« app (optional)</b>	<b>39</b>
<b>Steuerung mit dem »air« controller (optional)</b>	<b>43</b>	<b>Control with the »air« controller (optional)</b>	<b>43</b>
<b>Dimmen mit dem Lichtschalter (optional)</b>	<b>47</b>	<b>Dimming with the light switch (optional)</b>	<b>47</b>
Anhang	51	Appendix	51
Pflegehinweise	52	Care instructions	52
Info & Kontakt	53	Information & contact	53
Technische Daten	54	Technical data	56

# Sicherheitshinweise

Lesen Sie die Montage-/Gebrauchsanweisung sorgfältig durch, bevor Sie die Leuchte installieren. Beachten Sie die Sicherheitshinweise in dieser Anleitung genau und bewahren Sie die Anleitung auf.



Dieses Zeichen macht Sie auf eine gefährliche Situation aufmerksam, die eine schwere Verletzung oder den Tod nach sich ziehen kann, wenn sie nicht beachtet wird. Es macht Sie zudem auf mögliche Sachschäden und andere wichtige Informationen in Verbindung mit diesem Produkt aufmerksam.



Die Montage von Elektrokomponenten darf nur von qualifiziertem Fachpersonal durchgeführt werden. Reparaturarbeiten dürfen nur von autorisiertem Fachpersonal oder dem Hersteller durchgeführt werden. Vor allen Arbeiten am Strahler (Installation, Leuchtmittelwechsel, Reinigung etc.) diesen unbedingt vom Stromnetz trennen.



Dieses Zeichen macht Sie auf Situationen aufmerksam, bei denen Sie direkt in das Licht der LED blicken könnten. Dies kann zu Nachbildern und bei längerer Dauer zu Schädigungen der Augen führen.



Sicherheitsabstand zu brennbaren Objekten einhalten: 20 cm!



Dieses Zeichen macht Sie auf heiße Oberflächen aufmerksam, deren Berührung Verbrennungen zur Folge haben können.

Achtung: Die Oberfläche des Strahlers kann nach längerer Betriebsdauer heiß sein! Vor allen Arbeiten am Strahler (Montage des Strahlers, Wechsel des Leuchtmittels, Wechsel der Inserts, usw.), Strahler immer ausschalten und mindestens 30 Minuten abkühlen lassen. Nur zur Installation außerhalb des Handbereichs vorgesehen.

## Safety precautions

Read through the mounting/ use instructions carefully before installing the luminaire. Follow the safety precautions in these instructions closely and keep the instructions in a safe place.



This symbol warns you of a dangerous situation which could lead to serious injury or even death if the instructions are not observed. It also draws your attention to possible material damage and provides other important information in connection with this product.



The assembly and installation of electrical components must be carried out only by qualified personnel. Repairs must be carried out only by authorised, qualified personnel or the manufacturer. Before performing any work on the spotlight (installation, changing the light source, cleaning, etc.), it must be disconnected from the mains supply.



This symbol draws your attention to situations in which you could look directly into the light of the LED. This may cause an after-image effect and may result in damage to the eyes if you look at the light directly for prolonged periods.



Maintain the minimum safety distance from flammable materials: 20 cm.



This symbol warns you of hot surfaces, which could cause burns if touched.

Caution: When used for prolonged periods, the surface of the spotlight can become hot. Before performing any work on the spotlight (fitting the spotlight, changing the light source or insert, etc.), always switch the spotlight off and let it cool for at least 30 minutes. Only for installing in a position which is out of arm's reach.

# Produktbeschreibung

LED Deckenstrahler mit zwei Köpfen und einseitigem Lichtaustritt. Wahlweise mit Linsenoptik (Più) oder flachem cone Glas mit innenliegender Linse (Più R).

Version für Aufputzmontage, Anschluss an 230V AC / 50Hz Netzspannung, dimmbar via Phasenabschrittdimmer\*.

## **Più alto doppio**

Die Leuchtenköpfe sind frei drehbar (mit Anschlag) und über ein integriertes Gelenk 52° schwenkbar, für den Einsatz als Downlight in vertikaler Position fixierbar.

Lichtwirkung durch optionale inserts jederzeit über einen einfachen Mechanismus veränderbar, dichroitische Farbfilter zusätzlich einsetzbar, VOLT light engine wechselbar.

## **Più alto 3d doppio**

Die Leuchtenköpfe sind frei beweglich durch die Occhio 3d-Kinematik mit zwei im Winkel von 45° zueinander stehenden Drehachsen.

Lichtwirkung durch optionale inserts jederzeit über einen einfachen Mechanismus veränderbar, dichroitische Farbfilter zusätzlich einsetzbar, VOLT light engine wechselbar.

\* Liste kompatibler Dimmer:  
[www.occhio.de/dim](http://www.occhio.de/dim)

## Product description

LED ceiling spotlight with two heads and single-sided light output. Optionally available with lens optics (Più) or flat cone glass with internal lens (Più R).

Version for mounting on plaster surfaces; connection to 230V AC / 50 Hz mains voltage; dimmable via trailing-edge phase-cut dimmer\*.

### **Più alto doppio**

The luminaire heads are freely rotatable (with stop) and pivotable by 52° thanks to its integrated joint; can be fixed in a vertical position for use as a downlight.

Lighting effect through optional inserts can be changed at any time using a simple mechanism, dichroic colour filter can be additionally inserted; the VOLT light engine is replaceable.

### **Più alto 3d doppio**

The luminaire heads are movable in any direction thanks to the Occhio 3D kinematics with two pivots set at an angle of 45° to each other.

Lighting effect through optional inserts can be changed at any time using a simple mechanism, dichroic colour filter can be additionally inserted; the VOLT light engine is replaceable.

\* For a list of compatible dimmers, see [www.occhio.de/dim\\_en](http://www.occhio.de/dim_en)





Montage  
head

Assembling  
the head

# Aufbau Più alto head

## Configuration Più alto head

Più

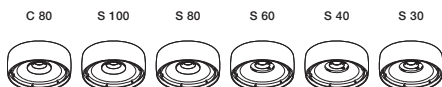

kleine Linse flach  
small lens low



kleine Linse medium  
small lens medium

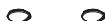

satiniertes Glas  
satinised glass



soft edge Glas  
soft edge glass



Fresnel Linse  
fresnel lens



Farbfilter (optional)  
color filter (optional)



Linse  
lens



80°,  
contour

100°, soft

80°, soft

60°, soft

40°, soft

30°, soft



## Più R

	B	C 100	C 80	S 100	S 80	S 60	S 40	S 30
kleine Linse flach small lens low								
kleine Linse medium small lens medium								
kleine Linse hoch small lens high								
satiniertes Glas satinised glass								
soft edge Glas soft edge glass								
Fresnel Linse fresnel lens								
Farbfilter (optional) color filter (optional)								
cone Glas								
diffus	100°, contour	80°, contour	100°, soft	80°, soft	60°, soft	40°, soft	30°, soft	

## cone Ring entfernen Removing the cone ring

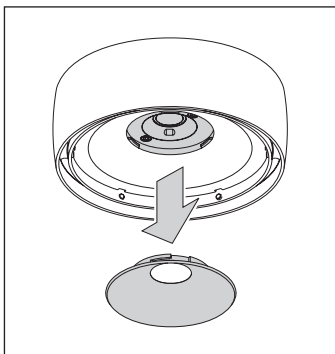
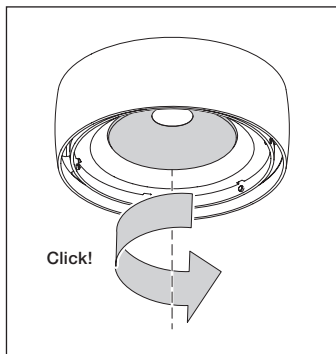

## cone Ring einsetzen Inserting the cone ring

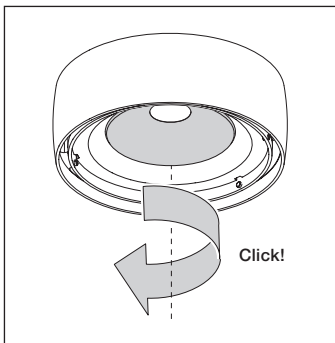
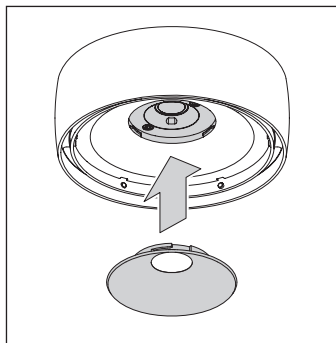

## Montage kleine Linse Assembling small lens

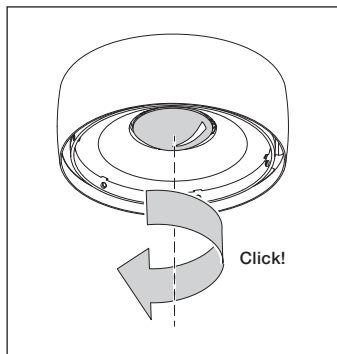
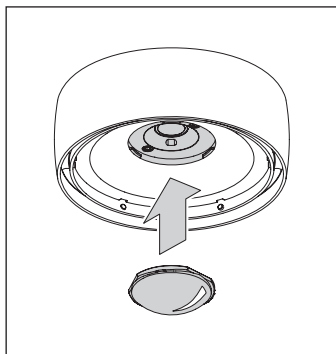

## kleine Linse entnehmen Removing small lens

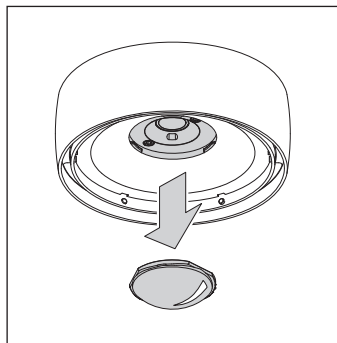
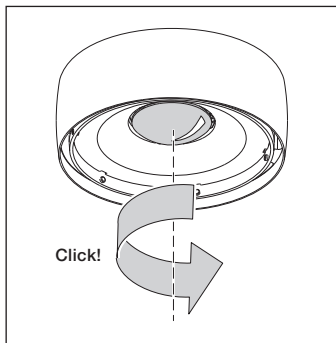

# Kombinationen der Inserts

## Insert combinations

**Fresnel Linse**  
fresnel lens

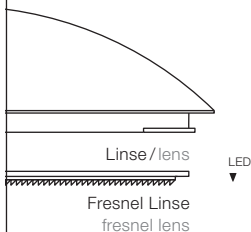

**Farbfilter in Kombination**  
Color filter in combination

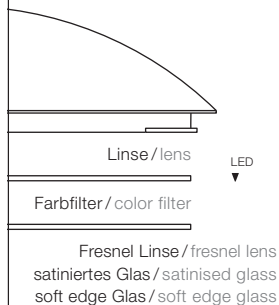

**Fresnel Linse**  
fresnel lens

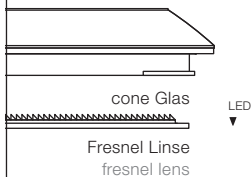

**Farbfilter in Kombination**  
Color filter in combination

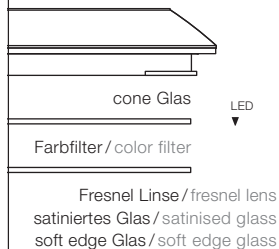

## Montage Inserts (alle Versionen) Fitting the inserts (all versions)

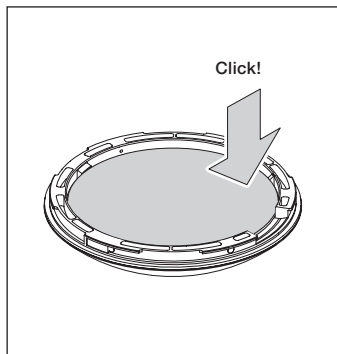
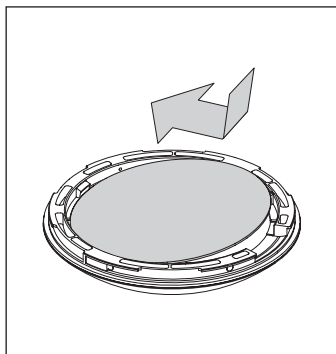

## Inserts entnehmen Removing the inserts

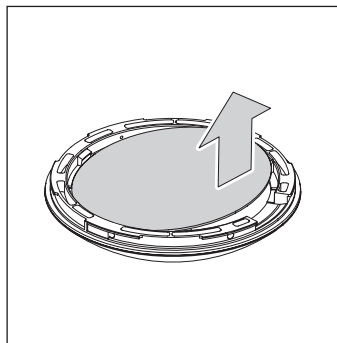
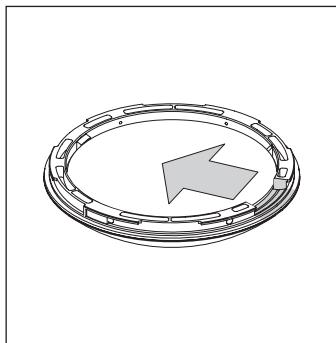

## Montage Linse / cone Glas (alle Versionen) Fitting the lens / cone glass (all versions)

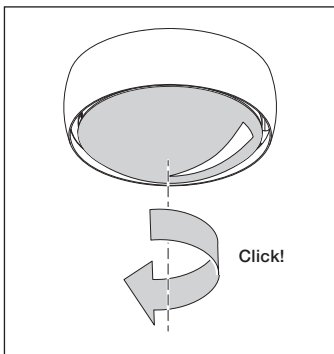
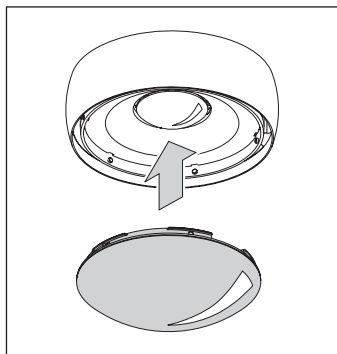

## Linse / cone Glas entnehmen Removing the lens / cone glass

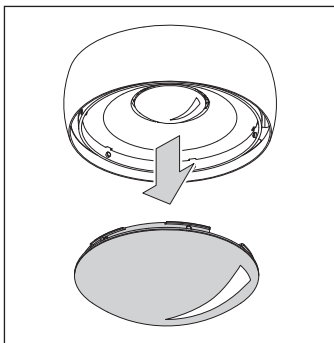
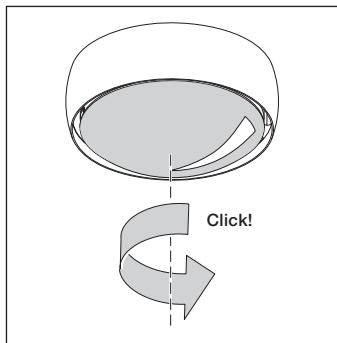



# Leistungseinstellung head

## Power setting head

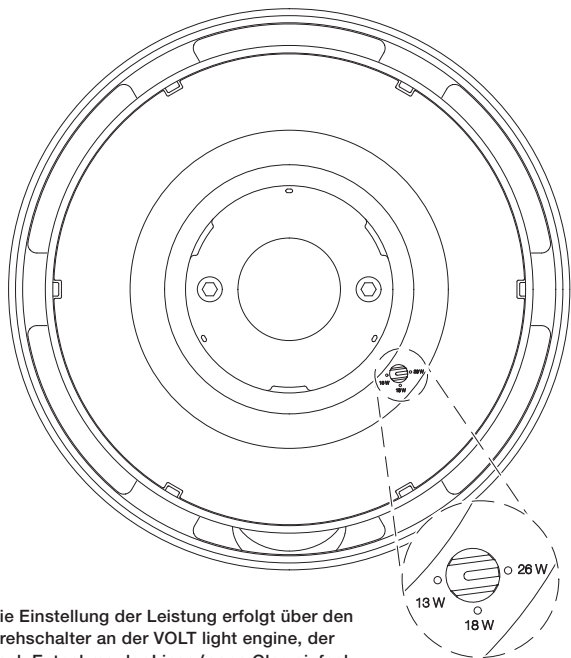

Die Einstellung der Leistung erfolgt über den Drehschalter an der VOLT light engine, der nach Entnahme der Linse / cone Glas einfach zu erreichen ist.

The power can be setup by the rotary switch on the VOLT light engine. After removing the lens / cone glass the rotary switch is easy reachable.



Montage  
Più doppio

Mounting  
Più doppio

# Montage Più doppio

## Mounting Più doppio

Deckenauslass/Ceiling outlet  
230V AC

Dübel/Screw anchor

Più doppio base

» air « module + Kabel (optional)

» air « module + cable (optional)

Schrauben/Screws

Più alto doppio

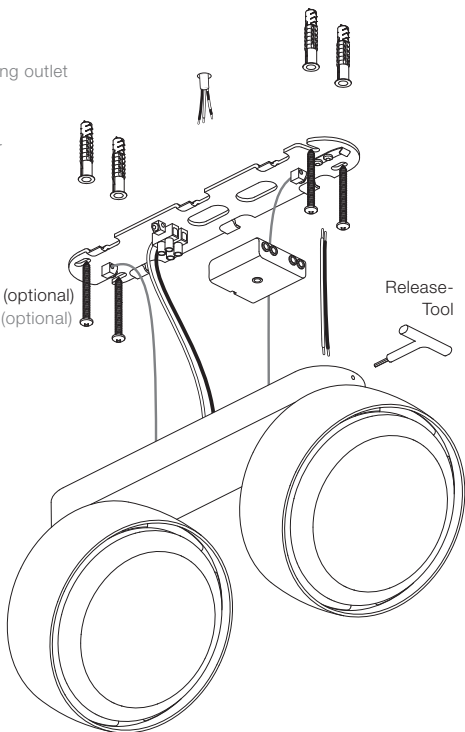



Deckenauslass / Ceiling outlet  
230 V AC

Dübel / Screw anchor

Più doppio base

»air« module + Kabel (optional)  
»air« module + cable (optional)

Schrauben / Screws

Più alto 3d doppio

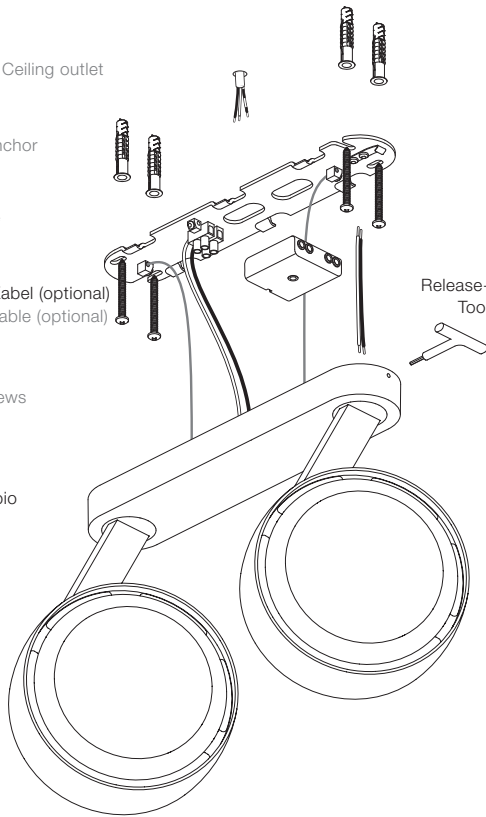

Montage Più doppio + »air« module (optional)  
Mounting Più doppio + »air« module (optional)

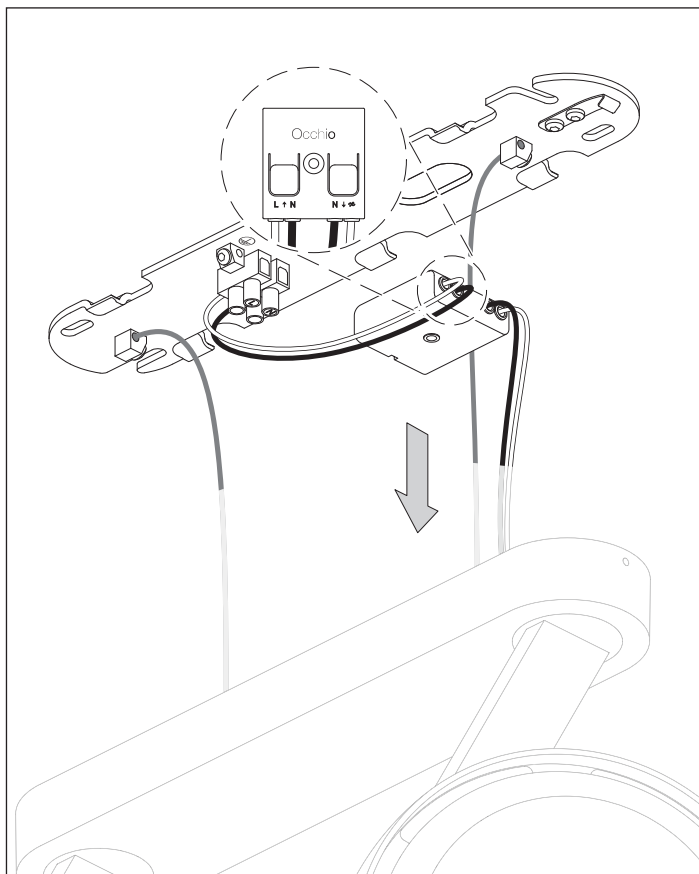

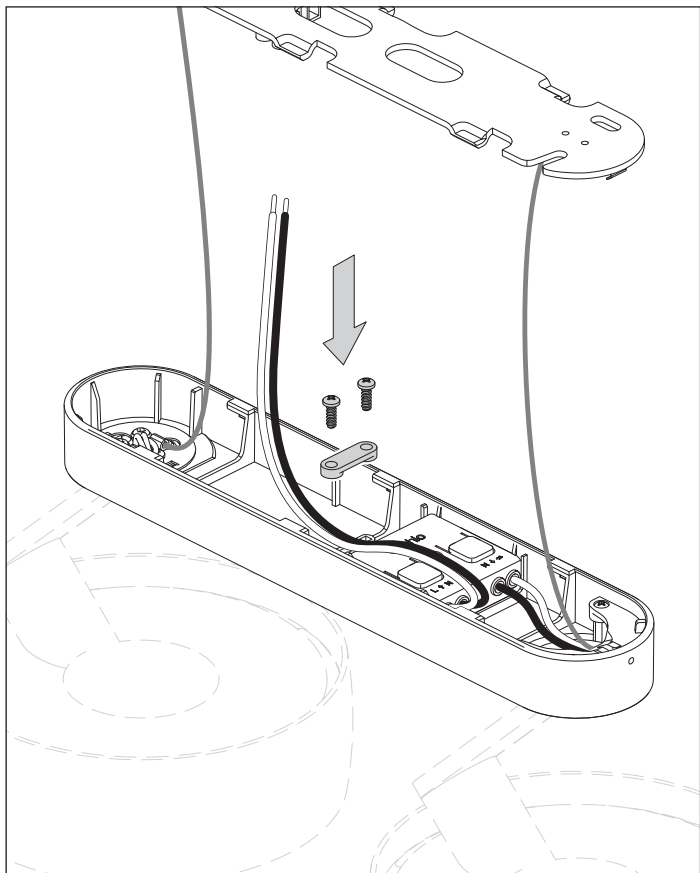
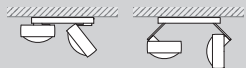

# Montage Più doppio

## Mounting Più doppio

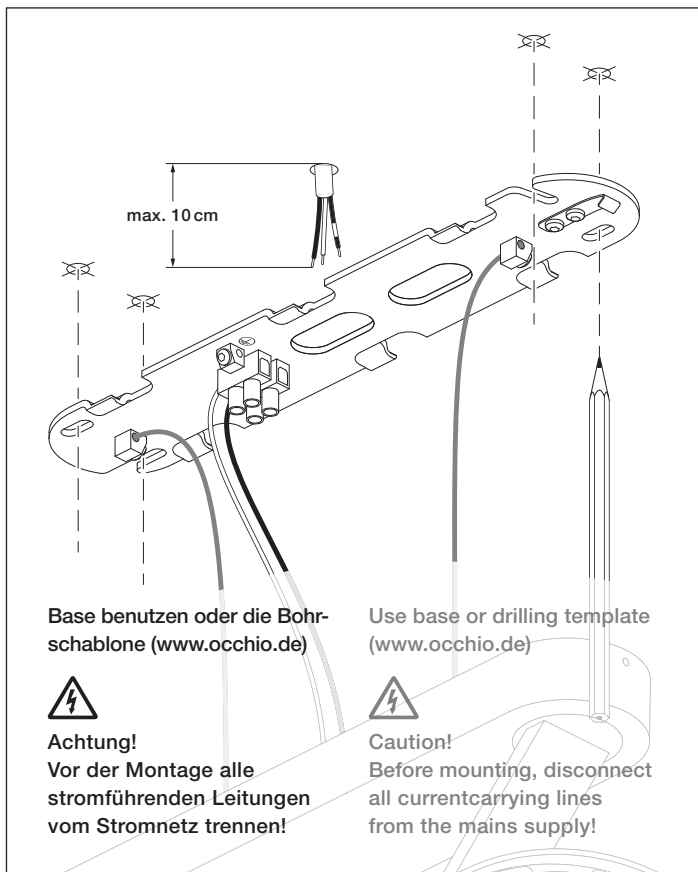





ø 6 mm



**Achtung!**  
Auf den Verlauf von  
Stromleitungen achten!



**Caution!**  
Check the routing of the  
power cables.

# Montage Più doppio

## Mounting Più doppio

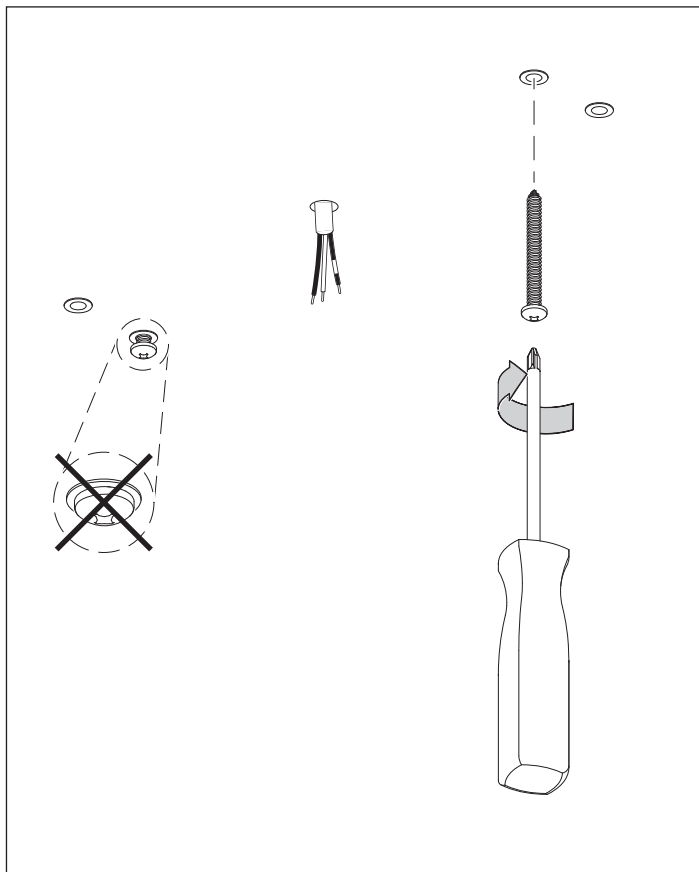

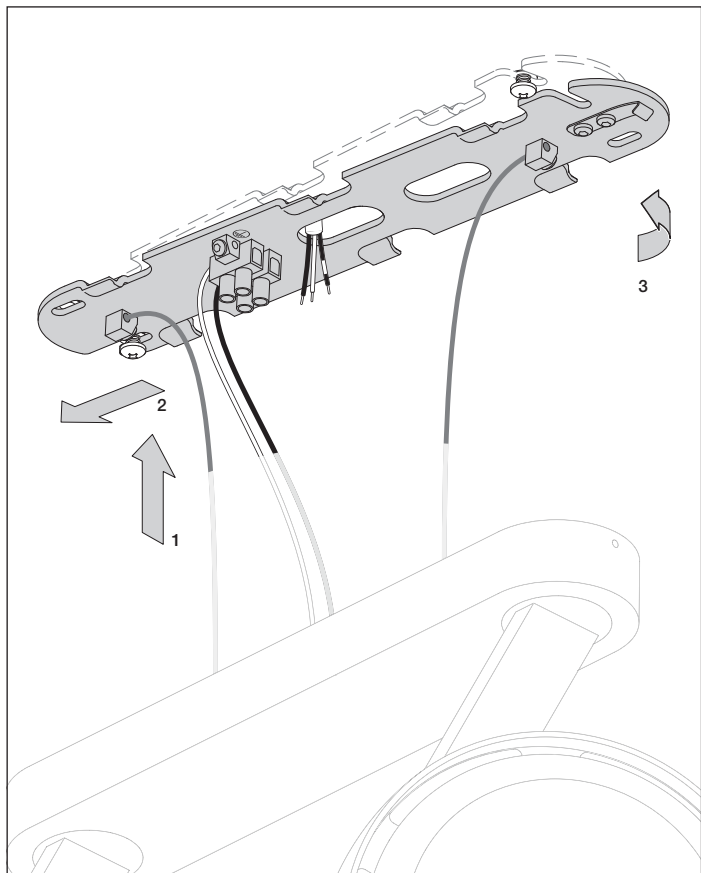
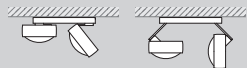

# Montage Più doppio

## Mounting Più doppio

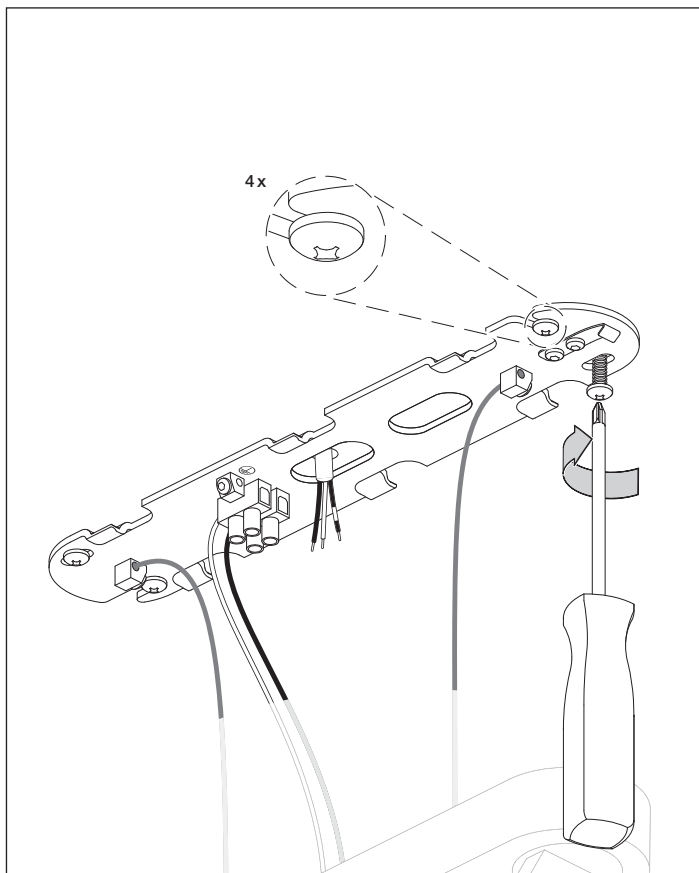

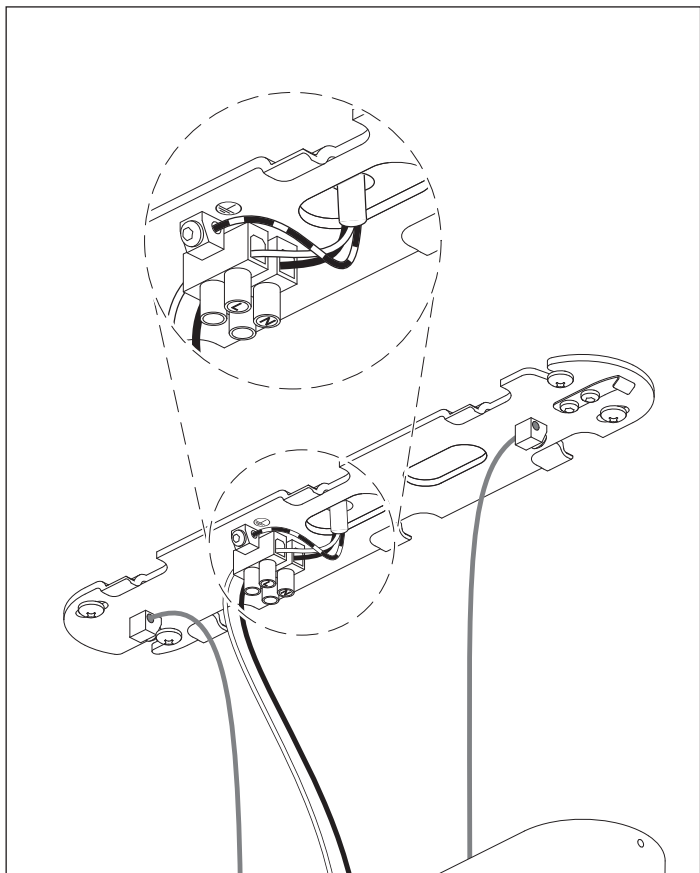
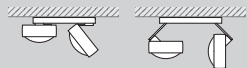

## Montage Più doppio Mounting Più doppio

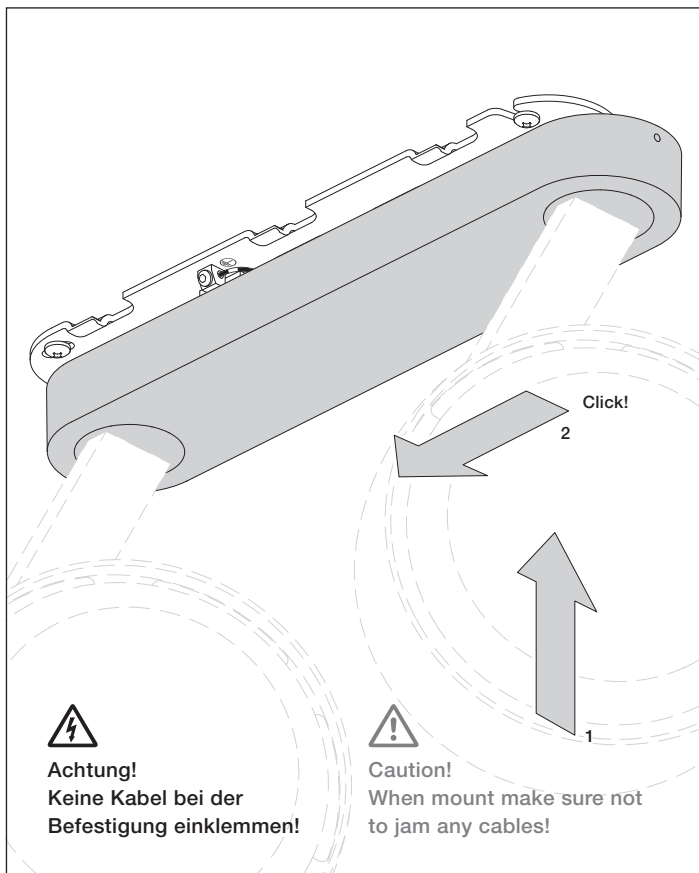

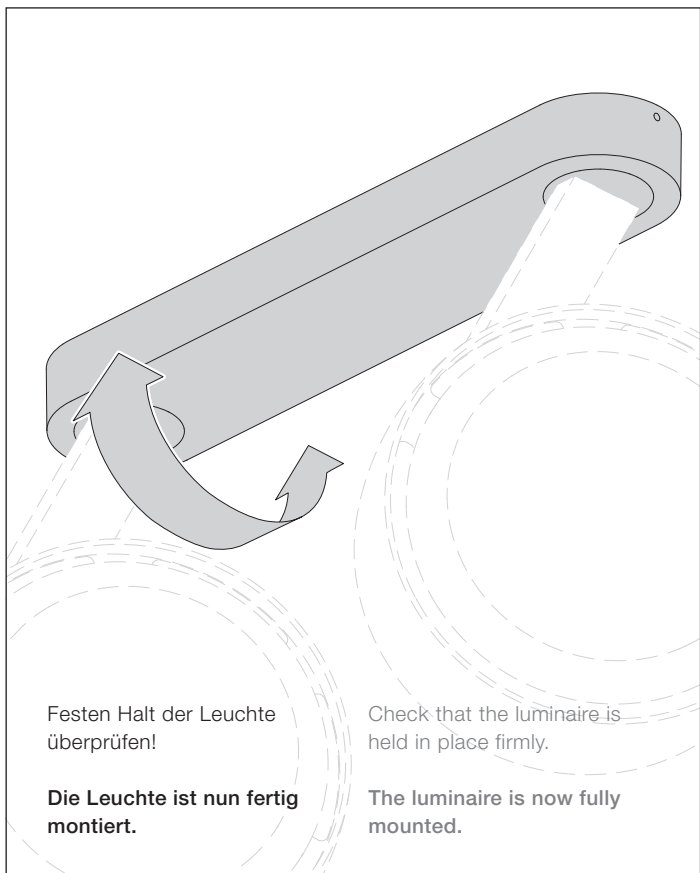

Festen Halt der Leuchte  
überprüfen!

**Die Leuchte ist nun fertig  
montiert.**

Check that the luminaire is  
held in place firmly.

**The luminaire is now fully  
mounted.**

## Montage Più doppio Mounting Più doppio

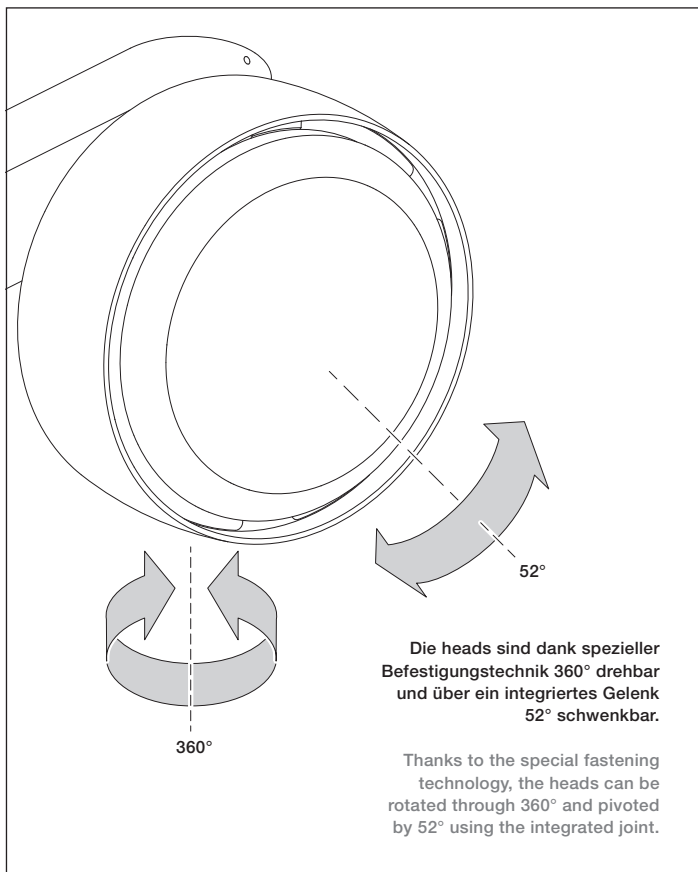





Die heads sind frei beweglich durch die Occhio 3d-Kinematik mit zwei im Winkel von 45° zueinander stehenden Drehachsen.

The heads are movable in any direction thanks to Occhio 3D kinematics with two pivots set at an angle of 45° to each other.

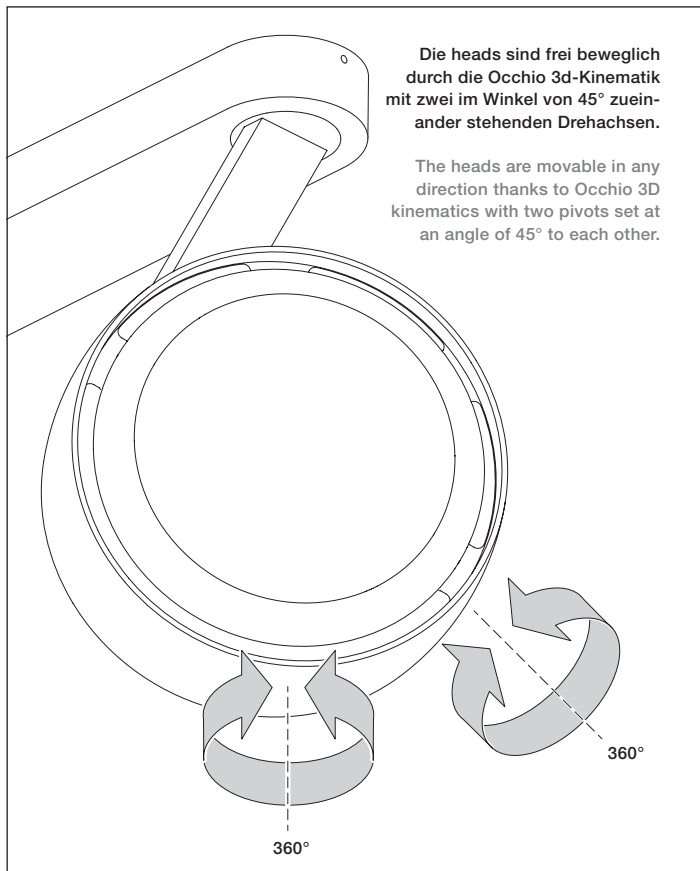



Demontage  
Più doppio

Removing  
Più doppio

## Demontage Più doppio Removing Più doppio

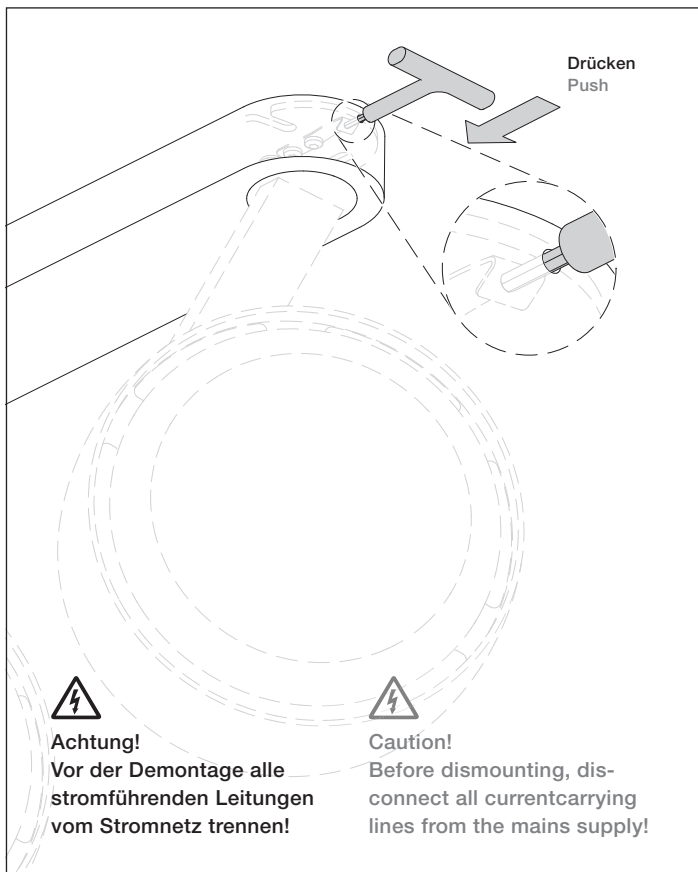

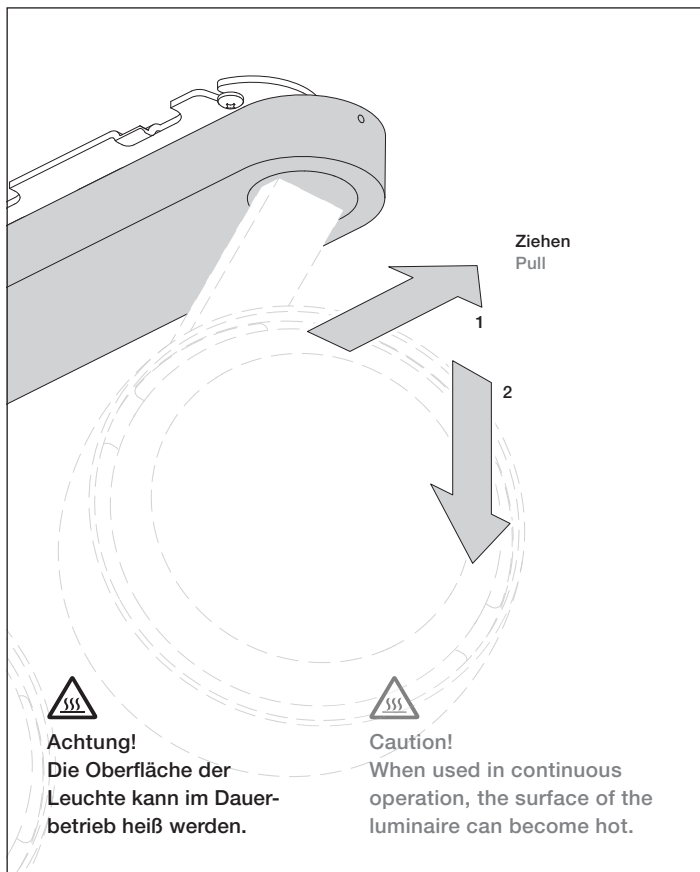



Steuerung mit  
der »air« App  
(optional)

Control with  
the »air« app  
(optional)

## Steuerung mit der »air« App (optional) Control with the »air« app (optional)



Die Occhio air Produkte lassen sich mit der »air« App einrichten und steuern, sie ist verfügbar für iOS- und Android-Geräte die im jeweiligen Store heruntergeladen werden kann.

Nach dem Öffnen der App, werden die Leuchten und Module, die sich im Empfangsbereich der App befinden, unter **Leuchten in meiner Nähe** angezeigt und können nun eingerichtet und gesteuert werden.

Eine Video-Kurzanleitung kann unter: [www.occhio.de/daten/tutorials/air/de](http://www.occhio.de/daten/tutorials/air/de) aufgerufen werden.







Occhio air products can be set up and controlled with the »air« app; it is available for iOS and Android devices and can be downloaded at the particular store.

After the app is opened, the luminaires and modules that are within the reception range of the app are displayed under **Luminaires near me** and can now be set up and controlled.

A video quick start guide can be called up at [www.occhio.de/daten/tutorials/air/en](http://www.occhio.de/daten/tutorials/air/en).



Steuerung  
mit dem  
»air« controller  
(optional)

Control  
with the  
»air« controller  
(optional)

# Steuerung mit dem »air« controller (optional)

## Control with the »air« controller (optional)

### Occhio air controller

Intuitiv bedienbare Fernbedienung mit vier programmierbaren Tasten (Einrichtung via Occhio air App). Unabhängig von der App können einzelne Leuchten, Gruppen und Szenen gesteuert werden. Optional mit Wandhalterung erhältlich.

Maximaler Bedienkomfort und umfassende Steuerung via Bluetooth 4.0 (Bluetooth Low Energy). Schalten, dimmen, »fading« von einzelnen Leuchten, Gruppen und Szenen.

### Occhio air controller

Intuitive remote control with four programmable buttons (setup via Occhio air app). Individual luminaires, groups and scenes can be controlled regardless of the app. Available with optional wall mount.



Maximum ease of use and total control via Bluetooth 4.0 (Bluetooth low energy). Switching, dimming, »fading« of individual luminaires, groups and scenes.







Zum Einrichten des Occhio air controllers wird die Occhio air App benötigt. Eine Video-Kurzanleitung kann unter: [www.occhio.de/daten/tutorials/air/de](http://www.occhio.de/daten/tutorials/air/de) aufgerufen werden.



To set up the Occhio air controller, the Occhio air app is required. A video quick start guide can be called up at [www.occhio.de/daten/tutorials/air/en](http://www.occhio.de/daten/tutorials/air/en).





Tasten  bis   
Szenen, Gruppen, einzelne  
Leuchten oder alle Leuchten  
steuern.

Buttons  to   
control scenes, groups,  
individual luminaires or all  
luminaires.

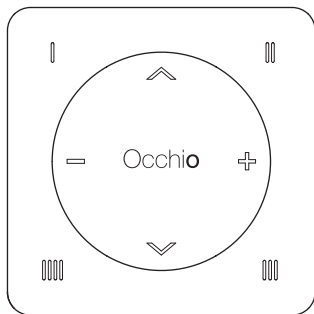

   
Szenen, Gruppen, einzelne  
Leuchten oder alle Leuchten  
dimmen.

   
Dims scenes, groups, individual  
luminaires or all luminaires.



   
Szenen, Gruppen,  
einzelne Leuchten oder  
alle Leuchten faden\*.

\* Leuchten mit beidseitigem Lichtaustritt.

   
Fades scenes, groups,  
individual luminaires or all  
luminaires\*.

\* Luminaires with light outlets on both sides.



Dimmen  
mit dem  
Lichtschalter  
(optional)

Dimming with  
the light switch  
(optional)

# Dimmen mit dem Lichtschalter (optional)

## Dimming with the light switch (optional)

### Dimmen mit dem Lichtschalter

Dimming with the light switch

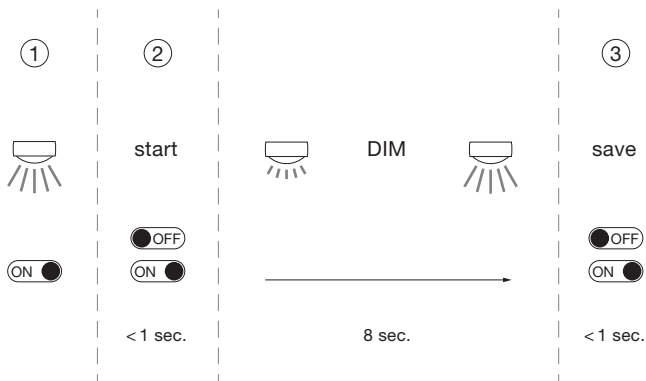





1. Leuchte mit Lichtschalter einschalten.
  2. Licht schnell aus- und einschalten. **Das Licht wird stufenlos heller.**
  3. Erneut das Licht schnell aus- und einschalten wenn die gewünschte Helligkeit erreicht ist. Die gewählte Helligkeit wird automatisch gespeichert.
1. Switch on the luminaire with the light switch.
  2. Quickly switch the light off and on. **The light becomes progressively brighter.**
  3. Once again, quickly switch the light off and on if the desired brightness has been reached. The selected brightness is automatically saved.

Wird der Lichtschalter nicht innerhalb von 8 Sekunden aus- und eingeschaltet, erreicht die Lichtintensität ihr Maximum.

If the light switch is not switched off and on within 8 seconds, then the light intensity reaches its maximum.

### Info

Der Lichtschalter kann über die App im Menüpunkt Smarter-Schalter unter Leuchteneinstellungen mit weiteren Funktionen belegt werden.

### Information

The light switch can be assigned additional functions via the app in the „Smarter switch“ menu item under luminaire settings.



#### Achtung!

**Die Steuerung des Lichtschalters ist nur mit dem »air« module möglich**



#### Caution!

**The control of the light switch is only possible with the »air« module**



Anhang

Appendix

## Pflegehinweise

### Care instructions

Leuchte nur in abgekühltem Zustand reinigen!

Zur Reinigung der Leuchte ein trockenes Mikrofasertuch oder Reinigungsmittel ohne Alkoholzusätze verwenden. Detaillierte Pflegehinweise sind unter [www.occhio.de/de/company/faq](http://www.occhio.de/de/company/faq) zu finden.

Always allow the luminaire to cool down before cleaning!

To clean the luminaire, use a dry microfibre cloth or an alcohol-free cleaning agent. Detailed care instructions are available at [www.occhio.de/en/company/faq](http://www.occhio.de/en/company/faq).

## Info & Kontakt

### Information & contact





Weitere Fragen beantwortet gerne  
Ihr Occhio Fachhändler

Your Occhio specialist retailer will  
gladly answer any other questions

**[www.occhio.de](http://www.occhio.de)**  
**[info@occhio.de](mailto:info@occhio.de)**

# Technische Daten

## Technische Daten Leuchte

Artikelbezeichnung	Più alto doppio Più alto 3d doppio
head	ø 123 mm, H 42 mm
Più alto doppio	base L 225 mm × B 45 mm × H 21,5 mm Gesamthöhe max. 144 mm
Più alto 3d doppio	base L 225 mm × B 45 mm × H 21,5 mm Gesamthöhe max. 185 mm
Schutzklasse	1
Anschluss	230 VAC, 50 Hz
Dimmung	via Phasenabschnittdimmer (Liste kompatibler Dimmer: <a href="http://www.occhio.de/dim">www.occhio.de/dim</a> )
Material Leuchte	Aluminium, Messing, Stahl verchromt oder lackiert
Material Inserts	Glas, optischer Kunststoff
LED-Leistung	2 × 26 W
Zulässige Betriebsbedingung	max. 30°C nur im Innenbereich betreiben
Prüfzeichen	<b>IP 20</b> <b>CE</b>      

## Technische Daten Leuchtmittel

Leuchtmittel	VOLT light engine
Ausführung	LED-Modul (wechselbar)
Lebensdauer	> 40.000 Std.

### Technische Daten Occhio air module (optional)

Artikelbezeichnung	Occhio air module
Modul	L 40xB 36xH 14 mm
Schutzklasse	2
Betriebsspannung	230 VAC, 50–60 Hz
Übertragungstechnologie	Bluetooth 4.0 (Bluetooth Low Energy)
Reichweite (umgebungsabhängig)	bis 20 m
Dimmung	phasenabschnittdimmbar
Zulässige Betriebsbedingung	max. 30°C, nur im Innenbereich betreiben
Prüfzeichen	IP 20 CE   

### Entsorgung

Bei örtlicher Entsorgungsstelle entsorgen. Più alto doppio,  
Più alto 3d doppio und das air module sind recyclebar;  
RoHS-konform. **Nicht in den Hausmüll geben!**

# Technical data

## Technical data luminaire

Product designation	Più alto doppio Più alto 3d doppio
head	ø 123 mm, H 42 mm
Più alto doppio	base L 225 mm × B 45 mm × H 21,5 mm Gesamthöhe max. 144 mm
Più alto 3d doppio	base L 225 mm × B 45 mm × H 21,5 mm Gesamthöhe max. 185 mm
Safety class	1
Connection	230 V AC 50 Hz
Dimming	via trailing-edge phase-cut dimmer (For a list of compatible dimmers, see <a href="http://www.occhio.de/dim_en">www.occhio.de/dim_en</a> )
Luminaire material	aluminium – chrome-plated, painted or anodised, plastic
Inserts material	optical plastic, glass
LED power	2 × 26 W
Permitted operating conditions	max. 30°C for indoor use only
Test symbols	<b>IP 20</b> <b>CE</b> <b>F</b>   

## Technical data light source

Light source	VOLT light engine
Version	LED module (replaceable)
Lifetime	> 40.000 h



### Technical data Occhio air module (optional)

Product designation	Occhio air module
Module	L 40xW 36xH 14 mm
Safety class	2
Connection	230 VAC, 50–60 Hz
Transmission technology	Bluetooth 4.0 (Bluetooth Low Energy)
Range (environment-dependent)	up to 20 m
Dimming	trailing-edge phase cut dimmable
Permitted operating conditions	max. 30°C for indoor use only
Test symbols	IP 20 CE   

### Disposal

Dispose of at a local disposal site. Più alto doppio, Più alto 3d doppio and the air module are recyclable and RoHS compliant. **Do not dispose of with the household waste!**





# Occhio

[www.occhio.com](http://www.occhio.com)



010405944597372710