

Occhio

io giro doppio

Montageanleitung
Mounting instructions

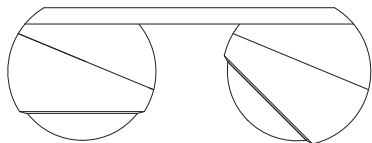

io giro doppio
io giro doppio + Occhio air



Inhalt / Contents

Sicherheitshinweise	04	Safety precautions	05
Produktbeschreibung	06	Product description	07
Montage Linse und inserts	09	Mounting lens and inserts	09
Montage io giro doppio	15	Mounting io giro doppio	15
Montage »air« adapter (optional)	20	Mounting »air« adapter (optional)	20
Demontage io giro doppio	35	Removing io giro doppio	35
Steuerung mit der »air« App	41	Control with the »air« app	41
Steuerung mit dem »air« controller (optional)	45	Control with the »air« controller (optional)	45
Dimmen mit dem Lichtschalter (optional)	49	Dimming with the light switch (optional)	49
Anhang	53	Appendix	53
Pflegehinweise	54	Care instructions	54
Info & Kontakt	55	Information & contact	55
Technische Daten	56	Technical data	58

Sicherheitshinweise

Lesen Sie die Montage-/Gebrauchsanweisung sorgfältig durch, bevor Sie die Leuchte installieren. Beachten Sie die Sicherheitshinweise in dieser Anleitung genau und bewahren Sie die Anleitung auf.



Dieses Zeichen macht Sie auf eine gefährliche Situation aufmerksam, die eine schwere Verletzung oder den Tod nach sich ziehen kann, wenn sie nicht beachtet wird. Es macht Sie zudem auf mögliche Sachschäden und andere wichtige Informationen in Verbindung mit diesem Produkt aufmerksam.



Die Montage von Elektrokomponenten darf nur von qualifiziertem Fachpersonal durchgeführt werden. Reparaturarbeiten dürfen nur von autorisiertem Fachpersonal oder dem Hersteller durchgeführt werden. Vor allen Arbeiten an der Leuchte (Montage, Leuchtmittelwechsel, Reinigung etc.) diesen unbedingt vom Stromnetz trennen.



Dieses Zeichen macht Sie auf Situationen aufmerksam, bei denen Sie direkt in das Licht der LED blicken könnten. Dies kann zu Nachbildern und bei längerer Dauer zu Schädigungen der Augen führen.



Sicherheitsabstand zu brennbaren Objekten einhalten: 20 cm!



Dieses Zeichen macht Sie auf heiße Oberflächen aufmerksam, deren Berührung Verbrennungen zur Folge haben können.

Achtung: Die Oberfläche der Leuchte kann nach längerer Betriebsdauer heiß sein! Vor allen Arbeiten an der Leuchte (Montage der Leuchte, Wechsel des Leuchtmittels, Wechsel der Inserts, usw.), Leuchte immer ausschalten und mindestens 30 Minuten abkühlen lassen. Nur zur Installation außerhalb des Handbereichs vorgesehen.

Safety precautions

Read through the mounting/ use instructions carefully before installing the luminaire. Follow the safety precautions in these instructions closely and keep the instructions in a safe place.



This symbol warns you of a dangerous situation which could lead to serious injury or even death if the instructions are not observed. It also draws your attention to possible material damage and provides other important information in connection with this product.



The assembly and installation of electrical components must be carried out only by qualified personnel. Repairs must be carried out only by authorised, qualified personnel or the manufacturer. Before performing any work on the spotlight (installation, changing the light source, cleaning, etc.), it must be disconnected from the mains supply.



This symbol draws your attention to situations in which you could look directly into the light of the LED. This may cause an after-image effect and may result in damage to the eyes if you look at the light directly for prolonged periods.



Maintain the minimum safety distance from flammable materials: 20 cm.



This symbol warns you of hot surfaces, which could cause burns if touched.

Caution: When used for prolonged periods, the surface of the spotlight can become hot. Before performing any work on the spotlight (fitting the spotlight, changing the light source or insert, etc.), always switch the spotlight off and let it cool for at least 30 minutes. Only for installing in a position which is out of arm's reach.

Produktbeschreibung

io giro doppio

LED Deckenstrahler mit zwei kugelförmigen Köpfen und Linsenoptik. Version für Aufputzmontage, Anschluss an 230 V AC 50 Hz Netzspannung, dimmbar via Phasenabschnittdimmer*.

Die heads sind dank der fast unsichtbaren Trennung der beiden Kugelhälften frei drehbar (mit Anschlag) und aus der Senkrechten um bis zu 45° schwenkbar. Lichtwirkung durch optionale inserts jederzeit über einen einfachen Mechanismus veränderbar, VOLT light engine wechselbar.

Weitere Versionen: io giro, io alto v (Aufbaustrahler), io piano, io piano v (Einbaustrahler).

Occhio air adapter

Adapter inkl. »air« module, Montage unter base, Seiteneinspeisung möglich.

Occhio air module

Bluetooth Dimmermodul, Montage in »air« adapter.

Maximaler Bedienkomfort und umfassende Steuerung via Bluetooth 4.0 (Bluetooth Low Energy). Schalten und dimmen von einzelnen Leuchten, Gruppen und Szenen.

* Liste kompatibler Dimmer:
www.occhio.de/dim

Product description

io giro doppio

LED ceiling spotlight with two spherical heads and lens optics. Version for mounting on plaster surfaces; connection to 230 V AC 50 Hz mains voltage; dimmable via trailing-edge phase-cut dimmer*.

Thanks to the almost invisible division of the two halves of the sphere, the heads are freely rotatable (with stop) and pivotable by up to 45° on the vertical axis. Lighting effect through optional inserts can be changed at any time using a simple mechanism; the VOLT light engine is replaceable.

Other versions: io giro, io alto v (surface-mounted spotlight), io piano, io piano v (recessed spotlight).

Occhio air adapter

Adapter including »air« module installation under base, side feed possible.

Occhio air module

Bluetooth dimmer module, mounting in »air« adapter.

Maximum ease of use and total control via Bluetooth 4.0 (Bluetooth low energy). Switching and dimming of individual luminaires, groups and scenes.

* For a list of compatible dimmers, see www.occhio.de/dim_en

Montage Linse
und inserts

Mounting lens
and inserts

Linse und inserts einsetzen

Inserting lens and inserts

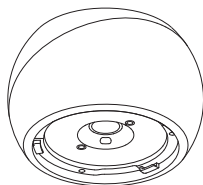
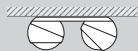

head



Blende* / aperture*



soft edge Glas*
soft edge glass*



satiniertes Glas
satinised glass



fresnel Linse
fresnel lens



Linse
lens

* Im Lieferumfang enthalten
* Included in the scope of delivery

Linse entnehmen Removing lens

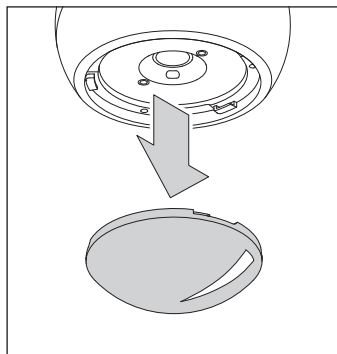
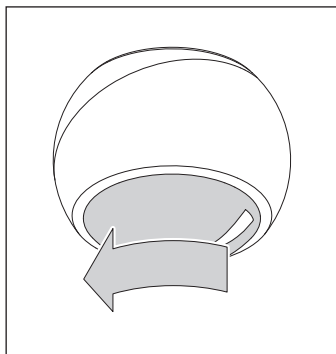
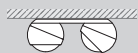

Linse einsetzen Inserting lens

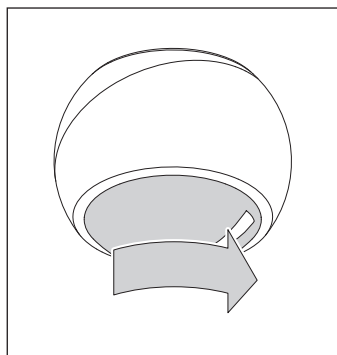
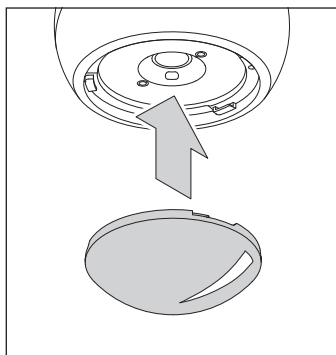
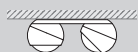

Inserts einsetzen (optional)
Inserting inserts (optional)

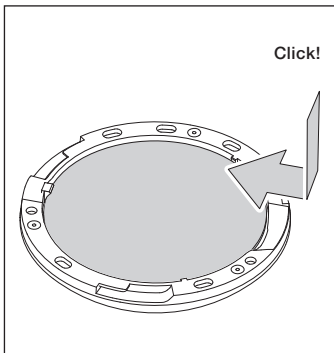
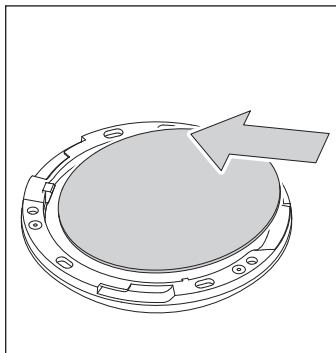
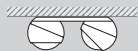

Inserts entnehmen (optional)
Removing inserts (optional)

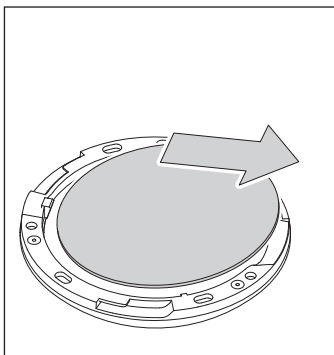
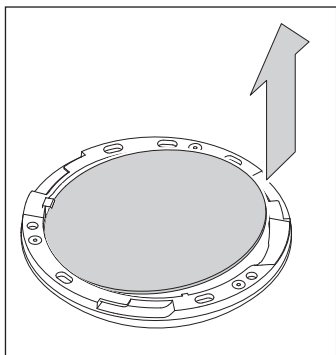
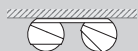

Blende einsetzen (optional) Inserting aperture (optional)

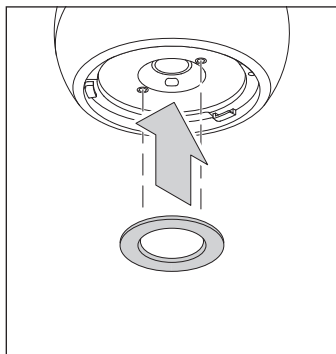
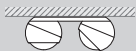

Blende entnehmen (optional) Removing aperture (optional)

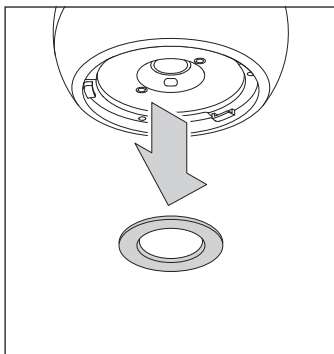
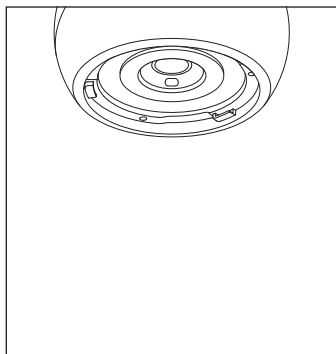
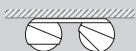

Montage
io giro doppio

Mounting
io giro doppio

Montage io giro doppio
Mounting io giro doppio

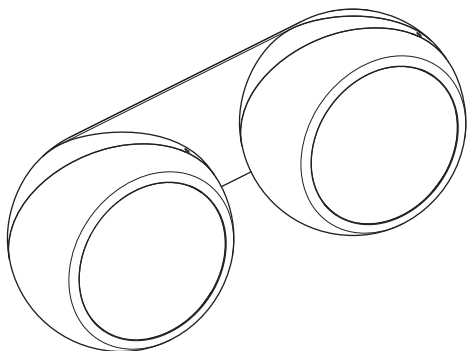

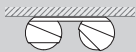

Deckenauslass / Ceiling outlet
230 V AC

Dübel / Screw anchor
Schrauben / Screws

»air« adapter (optional)
»air« module (optional)

Schrauben / Screws

io giro doppio
base

cover

head incl.
Linse / inserts
head incl.
lens / inserts

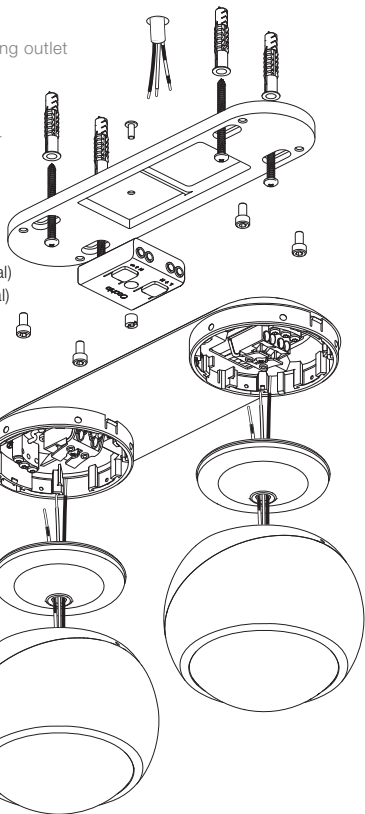

Release-
Tool



Montage io giro doppio

Mounting io giro doppio

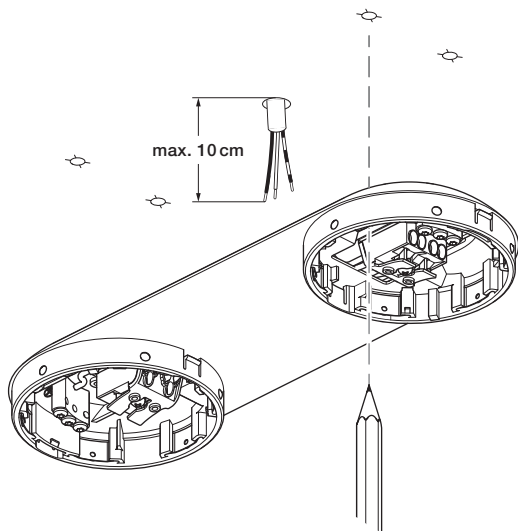

Base benutzen oder die Bohr-
schablone (www.occhio.de)



Achtung!
Vor der Montage alle
stromführenden Leitungen
vom Stromnetz trennen!

Use base or drilling template
(www.occhio.de)



Caution!
Before mounting, disconnect
all currentcarrying lines
from the mains supply!

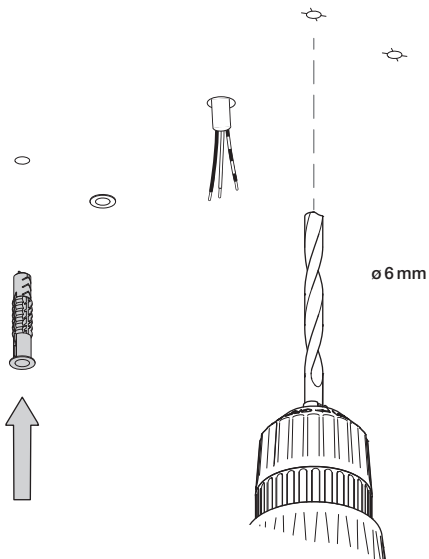
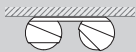

Achtung!
Auf den Verlauf von
Stromleitungen achten!



Caution!
Check the routing of the
power cables.

Montage »air« adapter (optional) Mounting »air« adapter (optional)

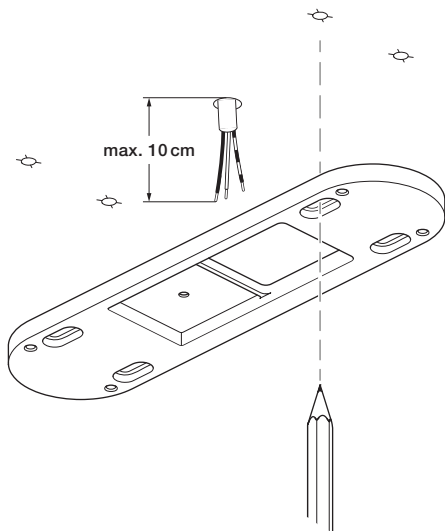

Base benutzen oder die Bohr-
schablone (www.occhio.de)



Achtung!
Vor der Montage alle
stromführenden Leitungen
vom Stromnetz trennen!

Use base or drilling template
(www.occhio.de)



Caution!
Before mounting, disconnect
all currentcarrying lines
from the mains supply!

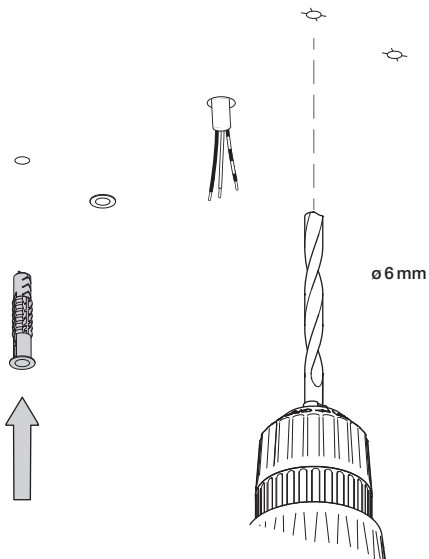
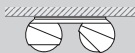

Achtung!
Auf den Verlauf von
Stromleitungen achten!



Caution!
Check the routing of the
power cables.

Montage »air« adapter (optional)

Mounting »air« adapter (optional)

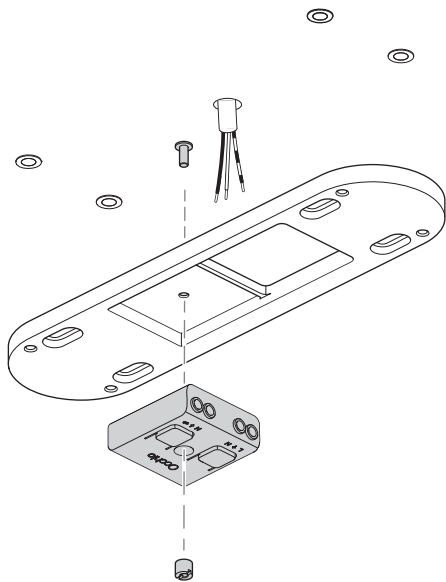

Occhio air module an den Adapter schrauben.

Screw the Occhio air module to the adapter.

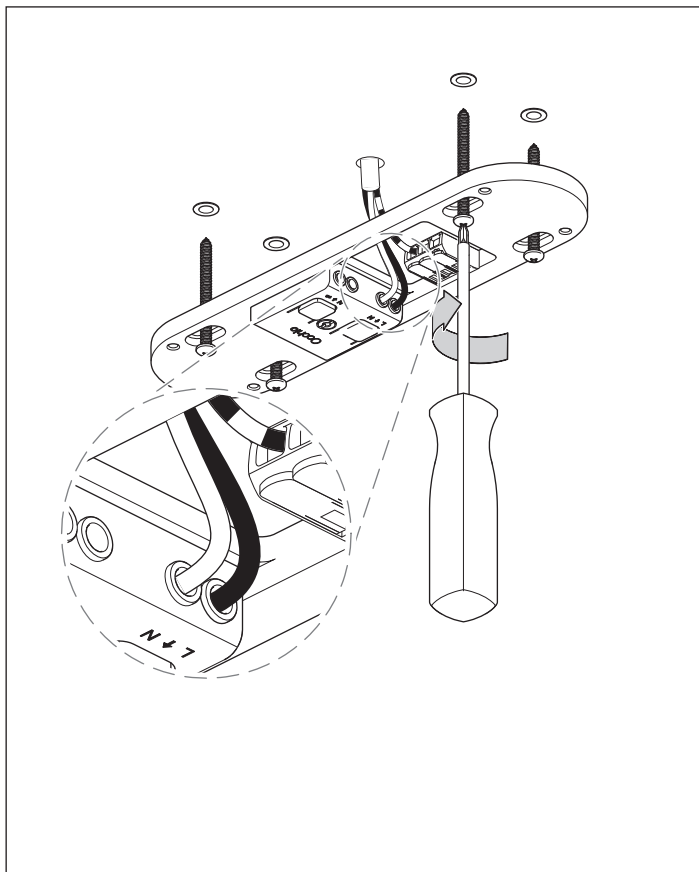
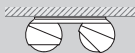

Montage »air« adapter (optional)
Mounting »air« adapter (optional)

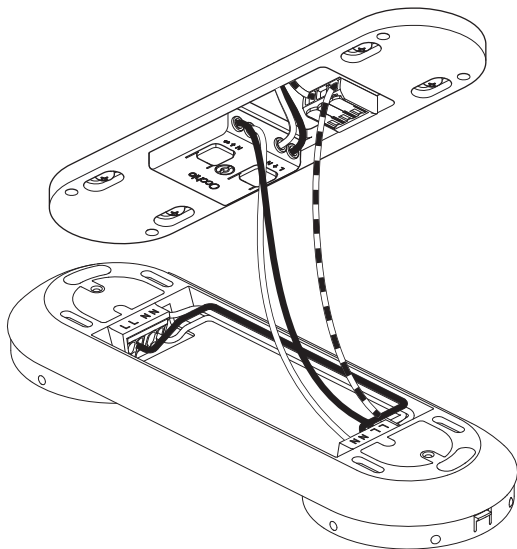

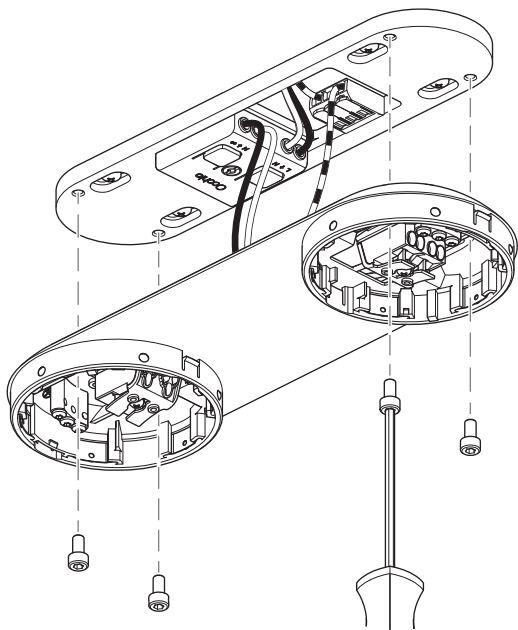
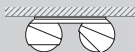

Achtung!
Keine Kabel bei der
Befestigung einklemmen!



Caution!
When mount make sure not
to jam any cables!

Montage io giro doppio Mounting io giro doppio

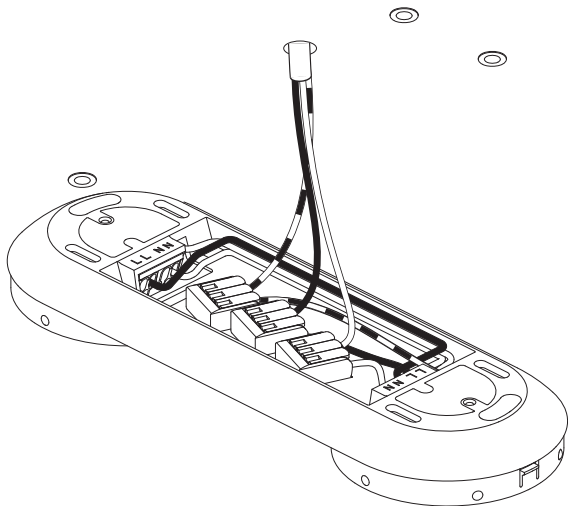

Achtung!
Keine Kabel bei der
Befestigung einklemmen!



Caution!
When mount make sure not
to jam any cables!

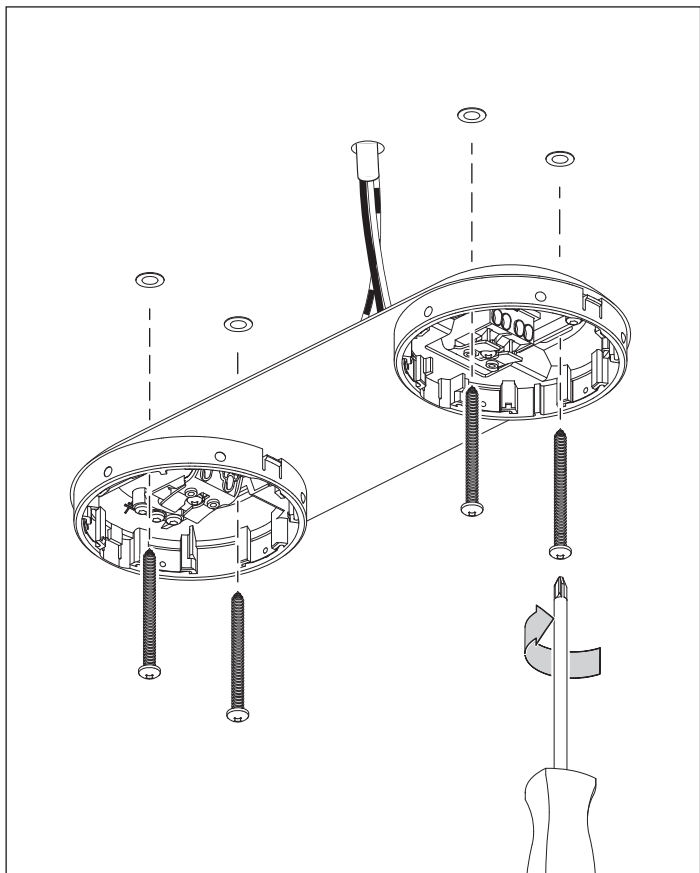
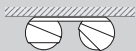

Montage io giro doppio
Mounting io giro doppio

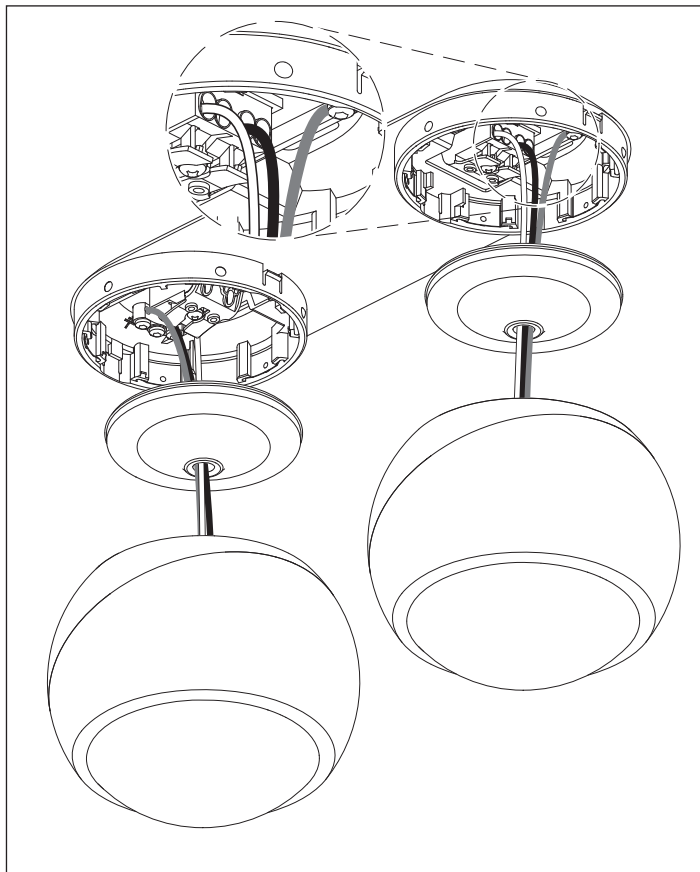

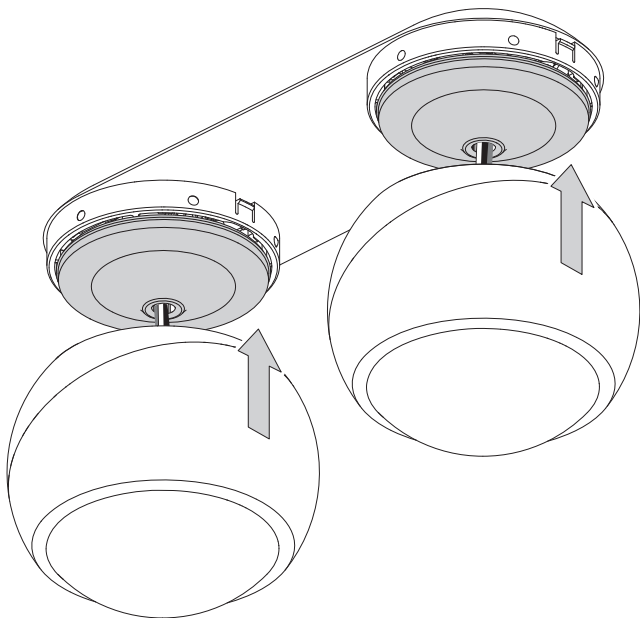
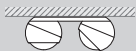

Achtung!
Keine Kabel bei der
Befestigung einklemmen!



Caution!
When mount make sure not
to jam any cables!

Montage io giro doppio
Mounting io giro doppio

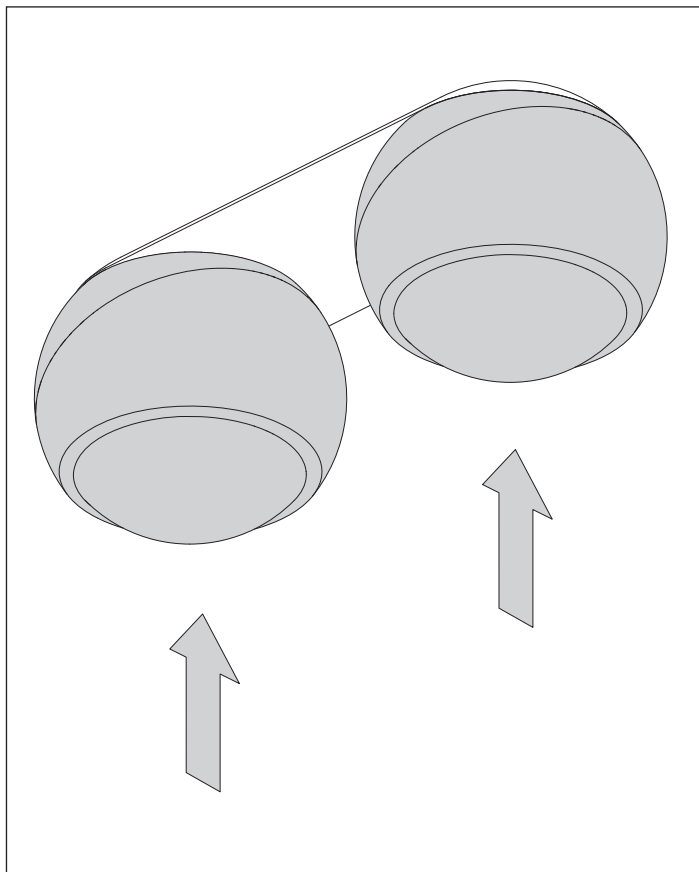

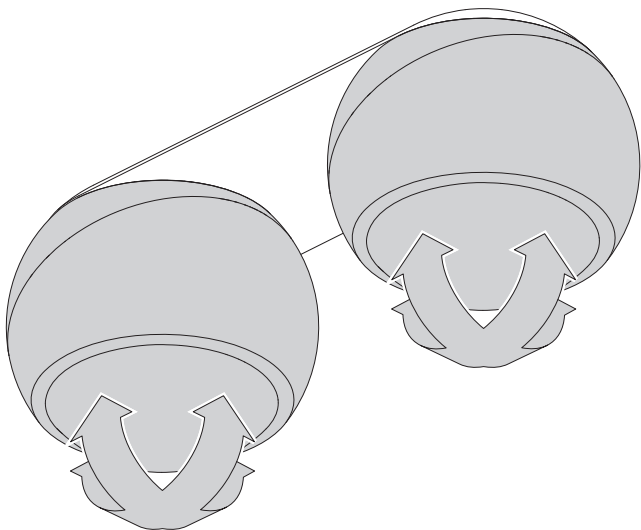
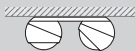

Festen Halt der Leuchte
überprüfen!

**Die Leuchte ist nun fertig
montiert.**

Check that the luminaire is
held in place firmly.

**The luminaire is now fully
mounted.**

Montage io giro doppio

Mounting io giro doppio

**Die heads sind rundum 360°
drehbar (mit Anschlag) und im
Winkel bis 45° ausrichtbar.**

The luminaire can be rotated
through 360° (with stop) and
adjusted to an angle of up to 45°.

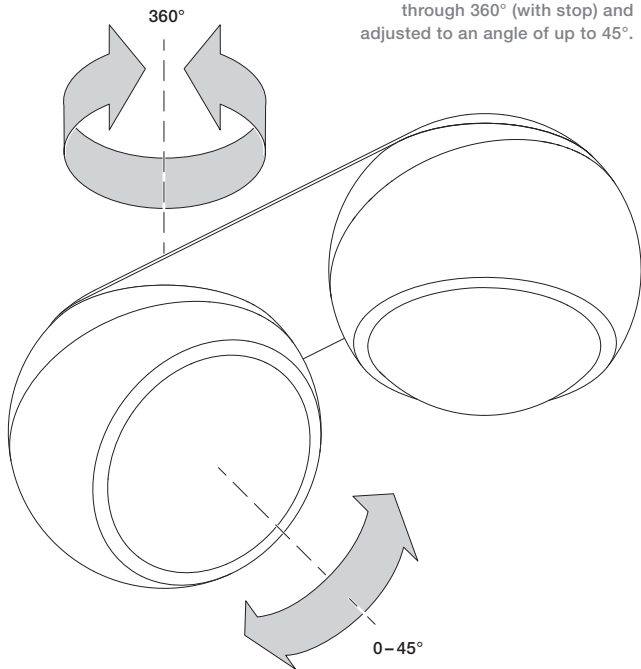

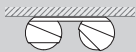

Demontage
io giro doppio

Removing
io giro doppio

Demontage io giro doppio Removing io giro doppio

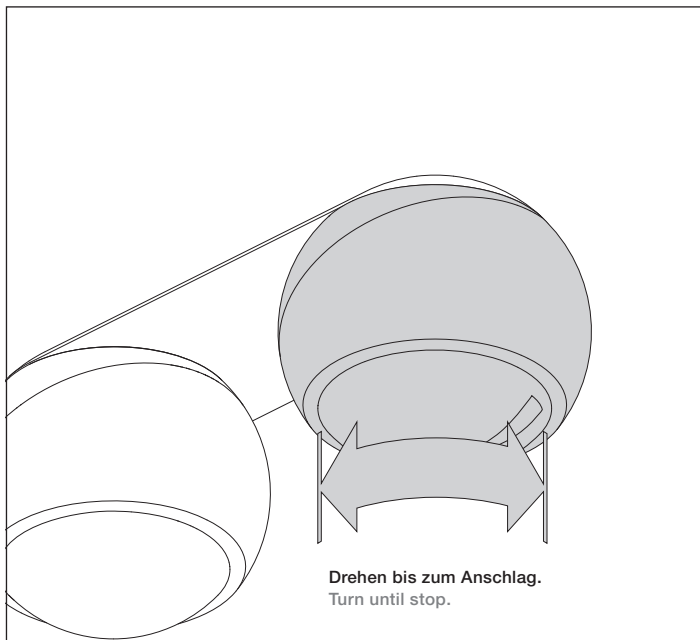

Drehen bis zum Anschlag.
Turn until stop.



Achtung!
Vor der Demontage alle
stromführenden Leitungen
vom Stromnetz trennen!



Caution!
Before dismounting, dis-
connect all currentcarrying
lines from the mains supply!

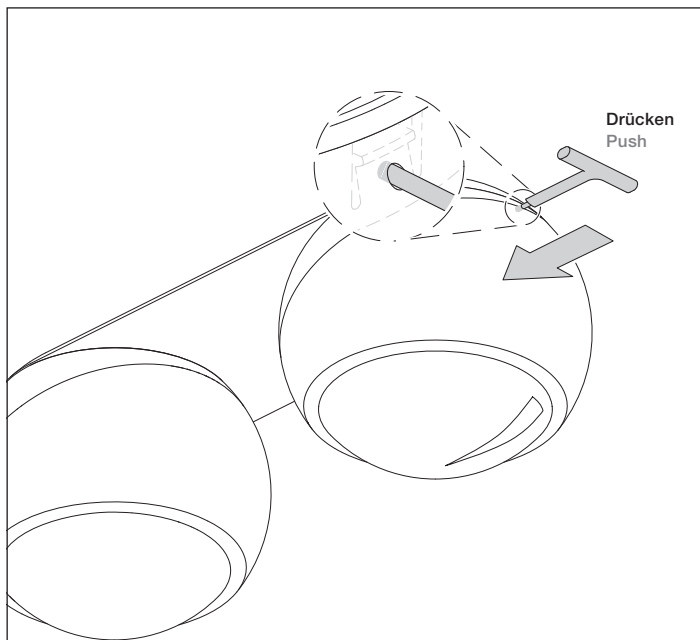
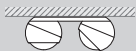

Achtung!
Die Oberfläche der
Leuchte kann im Dauer-
betrieb heiß werden.



Caution!
When used in continuous
operation, the surface of the
luminaire can become hot.

Demontage io giro doppio

Removing io giro doppio



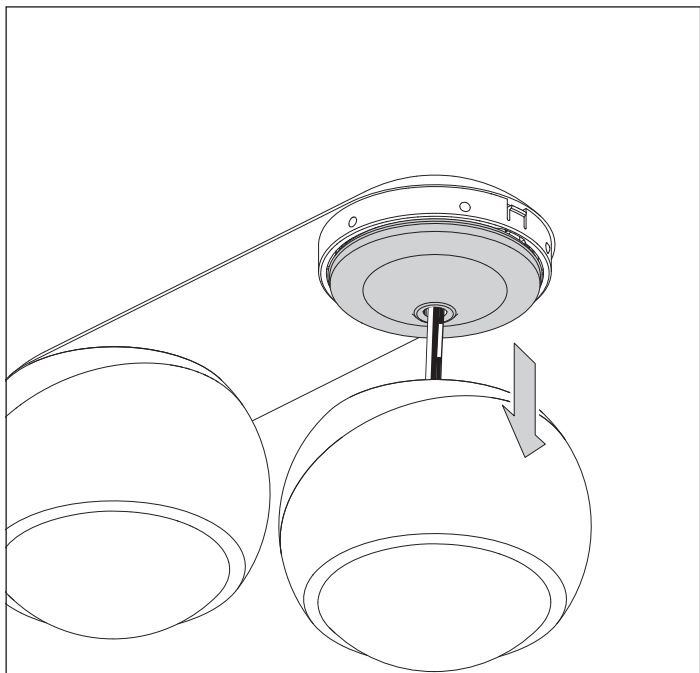
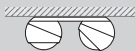

Achtung!
Bei der Entnahme keine
Kabel abreißen.



Caution!
Do not tear off any cables
when removing.

Steuerung mit
der »air« App

Control with
the »air« app

Steuerung mit der »air« App Control with the »air« app



Die Occhio air Produkte lassen sich mit der »air« App einrichten und steuern, sie ist verfügbar für iOS- und Android-Geräte die im jeweiligen Store heruntergeladen werden kann.

Nach dem Öffnen der App, werden die Leuchten und Module, die sich im Empfangsbereich der App befinden, unter **Leuchten in meiner Nähe** angezeigt und können nun eingerichtet und gesteuert werden.

Eine Video-Kurzanleitung kann unter: www.occhio.de/daten/tutorials/air/de aufgerufen werden.





Occhio air products can be set up and controlled with the »air« app; it is available for iOS and Android devices and can be downloaded at the particular store.

After the app is opened, the luminaires and modules that are within the reception range of the app are displayed under **Luminaires near me** and can now be set up and controlled.

A video quick start guide can be called up at www.occhio.de/daten/tutorials/air/en.

Steuerung
mit dem
»air« controller
(optional)

Control
with the
»air« controller
(optional)

Steuerung mit dem »air« controller (optional)

Control with the »air« controller (optional)

Occhio air controller

Intuitiv bedienbare Fernbedienung mit vier programmierbaren Tasten (Einrichtung via Occhio air App). Unabhängig von der App können einzelne Leuchten, Gruppen und Szenen gesteuert werden. Optional mit Wandhalterung erhältlich.

Maximaler Bedienkomfort und umfassende Steuerung via Bluetooth 4.0 (Bluetooth Low Energy). Schalten, dimmen, »fading« von einzelnen Leuchten, Gruppen und Szenen.

Occhio air controller

Intuitive remote control with four programmable buttons (setup via Occhio air app). Individual luminaires, groups and scenes can be controlled regardless of the app. Available with optional wall mount.



Maximum ease of use and total control via Bluetooth 4.0 (Bluetooth low energy). Switching, dimming, »fading« of individual luminaires, groups and scenes.







Zum Einrichten des Occhio air controllers wird die Occhio air App benötigt. Eine Video-Kurzanleitung kann unter: www.occhio.de/daten/tutorials/air/de aufgerufen werden.



To set up the Occhio air controller, the Occhio air app is required. A video quick start guide can be called up at www.occhio.de/daten/tutorials/air/en.





Tasten  bis 
Szenen, Gruppen, einzelne
Leuchten oder alle Leuchten
steuern.

Buttons  to 
control scenes, groups,
individual luminaires or all
luminaires.

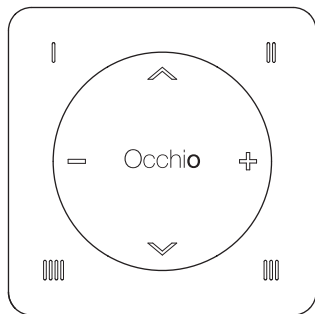

 
Szenen, Gruppen, einzelne
Leuchten oder alle Leuchten
dimmen.

 
Dims scenes, groups, individual
luminaires or all luminaires.



 
Szenen, Gruppen,
einzelne Leuchten oder
alle Leuchten faden*.

* Leuchten mit beidseitigem Lichtaustritt.

 
Fades scenes, groups,
individual luminaires or all
luminaires*.

* Luminaires with light outlets on both sides.

Dimmen
mit dem
Lichtschalter
(optional)

Dimming with
the light switch
(optional)

Dimmen mit dem Lichtschalter (optional)

Dimming with the light switch (optional)

Dimmen mit dem Lichtschalter

Dimming with the light switch

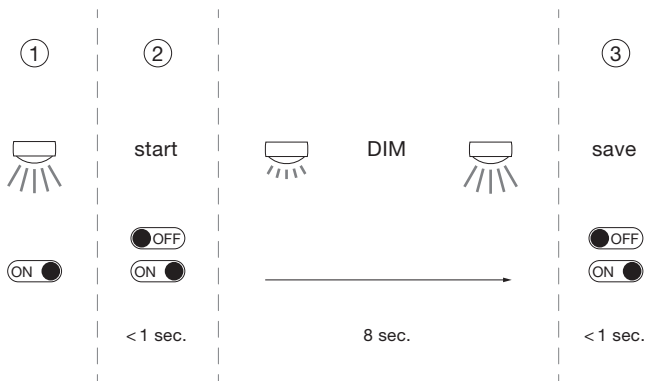



1. Leuchte mit Lichtschalter einschalten.
 2. Licht schnell aus- und einschalten. **Das Licht wird stufenlos heller.**
 3. Erneut das Licht schnell aus- und einschalten wenn die gewünschte Helligkeit erreicht ist. Die gewählte Helligkeit wird automatisch gespeichert.
1. Switch on the luminaire with the light switch.
 2. Quickly switch the light off and on. **The light becomes progressively brighter.**
 3. Once again, quickly switch the light off and on if the desired brightness has been reached. The selected brightness is automatically saved.

Wird der Lichtschalter nicht innerhalb von 8 Sekunden aus- und eingeschaltet, erreicht die Lichtintensität ihr Maximum.

If the light switch is not switched off and on within 8 seconds, then the light intensity reaches its maximum.

Info

Der Lichtschalter kann über die App im Menüpunkt Smarter-Schalter unter Leuchteneinstellungen mit weiteren Funktionen belegt werden.

Information

The light switch can be assigned additional functions via the app in the „Smarter switch“ menu item under luminaire settings.



Achtung!

Die Steuerung des Lichtschalters ist nur mit dem »air« module möglich



Caution!

The control of the light switch is only possible with the »air« module

Anhang

Appendix

Pflegehinweise

Care instructions

Leuchte nur in abgekühltem Zustand reinigen!

Zur Reinigung der Leuchte ein trockenes Mikrofasertuch oder Reinigungsmittel ohne Alkoholzusätze verwenden. Detaillierte Pflegehinweise sind unter www.occhio.de/de/company/faq zu finden.

Always allow the luminaire to cool down before cleaning!

To clean the luminaire, use a dry microfibre cloth or an alcohol-free cleaning agent. Detailed care instructions are available at www.occhio.de/en/company/faq.

Info & Kontakt

Information & contact

Weitere Fragen beantwortet gerne
Ihr Occhio Fachhändler

Your Occhio specialist retailer will
gladly answer any other questions

www.occhio.de
info@occhio.de

Technische Daten

Technische Daten Leuchte

Artikelbezeichnung	Occhio io giro doppio
Abmessungen	B 245 mm, H 90 mm, ø head 100 mm
Schutzklasse	1
Anschluss	230 V AC 50 Hz
Dimmung	via Phasenabschrittdimmer (Liste kompatibler Dimmer: www.occhio.de/dim)
Material Leuchte	Aluminium verchromt, lackiert oder eloxiert, Kunststoff
Material Inserts	Glas, optischer Kunststoff
LED-Leistung	2 x 13 W
Zulässige Betriebsbedingung	max. 30°C nur im Innenbereich betreiben
Prüfzeichen	IP 20 CE      





Technische Daten Leuchtmittel

Leuchtmittel	VOLT light engine
Ausführung	LED-Modul (wechselbar)
Lebensdauer	> 40.000 Std.

Technische Daten Occhio air adapter

Artikelbezeichnung	Occhio air adapter io giro doppio
Abmessungen	L 196 x B 51 x H 5,5 mm
Zulässige Betriebsbedingung	max. 30°C nur im Innenbereich betreiben
Prüfzeichen	IP 20 CE  

Technische Daten Occhio air module

Artikelbezeichnung	Occhio air module
Modul	L 40xB 36xH 14 mm
Schutzklasse	2
Betriebsspannung	230 VAC, 50–60 Hz
Übertragungstechnologie	Bluetooth 4.0 (Bluetooth Low Energy)
Reichweite (umgebungsabhängig)	bis 20 m
Dimmung	phasenabschnittdimmbar
max. Leistung	LED max. 4 x 32 W mit Occhio Konverter, (andere Konverter max. 52 W), HV Halogen oder HV LED max. 150 W, NV Halogen max. 60 W
Zulässige Betriebsbedingung	max. 30°C, nur im Innenbereich betreiben
Prüfzeichen	IP 20     

Entsorgung

Bei örtlicher Entsorgungsstelle entsorgen. Die io giro doppio, das air module und der air adapter sind recyclebar; RoHS-konform.

Nicht in den Hausmüll geben!

Technical data

Technical data luminaire

Product designation	Occhio io giro doppio
Dimensions	W 245 mm, H 90 mm, ø head 100 mm
Safety class	1
Connection	230 V AC 50 Hz
Dimming	via trailing-edge phase-cut dimmer (For a list of compatible dimmers, see www.occhio.de/dim_en)
Luminaire material	aluminium – chrome-plated, painted or anodised, plastic
Inserts material	optical plastic, glass
LED power	2 × 13 W
Permitted operating conditions	max. 30°C for indoor use only
Test symbols	IP 20      

Technical data light source

Light source	VOLT light engine
Version	LED module (replaceable)
Lifetime	> 40.000 h

Technical data Occhio air adapter

Product designation	Occhio air adapter io giro doppio
Dimensions	L 196 x B 51 x H 5,5 mm
Permitted operating conditions	max. 30°C for indoor use only
Test symbols	IP 20   

Technical data Occhio air module

Product designation	Occhio air module
Module	L 40xW 36xH 14 mm
Safety class	2
Connection	230 VAC, 50–60 Hz
Transmission technology	Bluetooth 4.0 (Bluetooth Low Energy)
Range (environment-dependent)	up to 20 m
Dimming	trailing-edge phase cut dimmable
Max. power	LED max. 4 x 32 W with Occhio converter, (other converters max. 52 W), HV halogen or HV LED max. 150 W, LV halogen max. 60 W
Permitted operating conditions	max. 30°C for indoor use only
Test symbols	IP 20 CE V I Q

Disposal

Dispose of at a local disposal site. The io giro doppio, the air module and the air adapter are recyclable and RoHS compliant.

Do not dispose of with the household waste!

Occhio

www.occhio.com



010404295697369010