

TAIO wall

INSTALLATION INSTRUCTIONS | MAY 2023

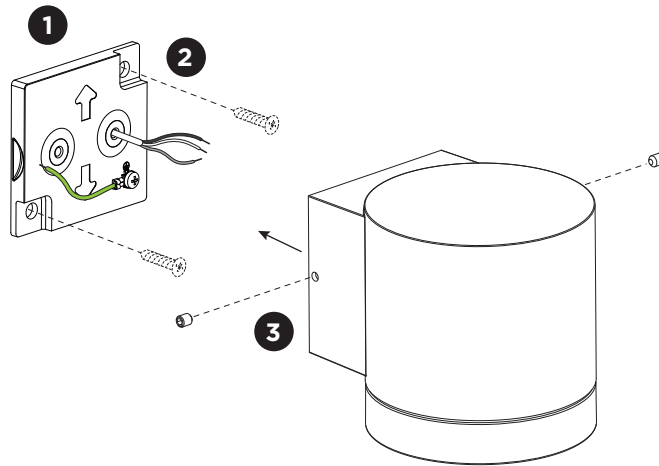

Mounting base:

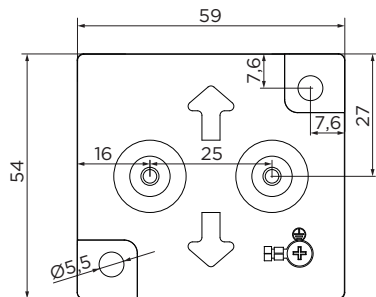

Always use a matching grommet in the overview table.

	A	B	C
CABLE			
TYPE	ROUND H05RN-F H07RN8-F H07RN-F	ROUND H05RN-F	ROUND
OUTSIDE Ø	min 6.8mm max 8.9mm	min 5mm max 6.8mm	min 1.5mm max 2.6mm
CONDUCTION SECTION	2or3x 0.75mm ² 2or3x 1.0mm ² 2or3x 1.5mm ²	2or3x 0.75mm ² 2x 1.0mm ²	0.75mm ² 1.5mm ²

DIMENSIONS

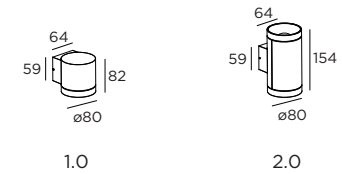

MOUNTING INSTRUCTION

- 1 Remove the mounting base from the luminaire by loosening the socket screws and mount it on the wall with screws (screws are not included).

- 2 **POWER CONNECTION**
Connect to 220-240V.

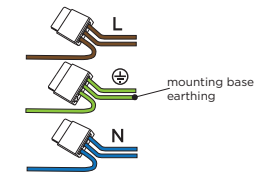

Connect the earth cable.



- 3 Fix the luminaire on the base with the socket screws.

TAIO wall

INSTALLATION INSTRUCTIONS | MAY 2023

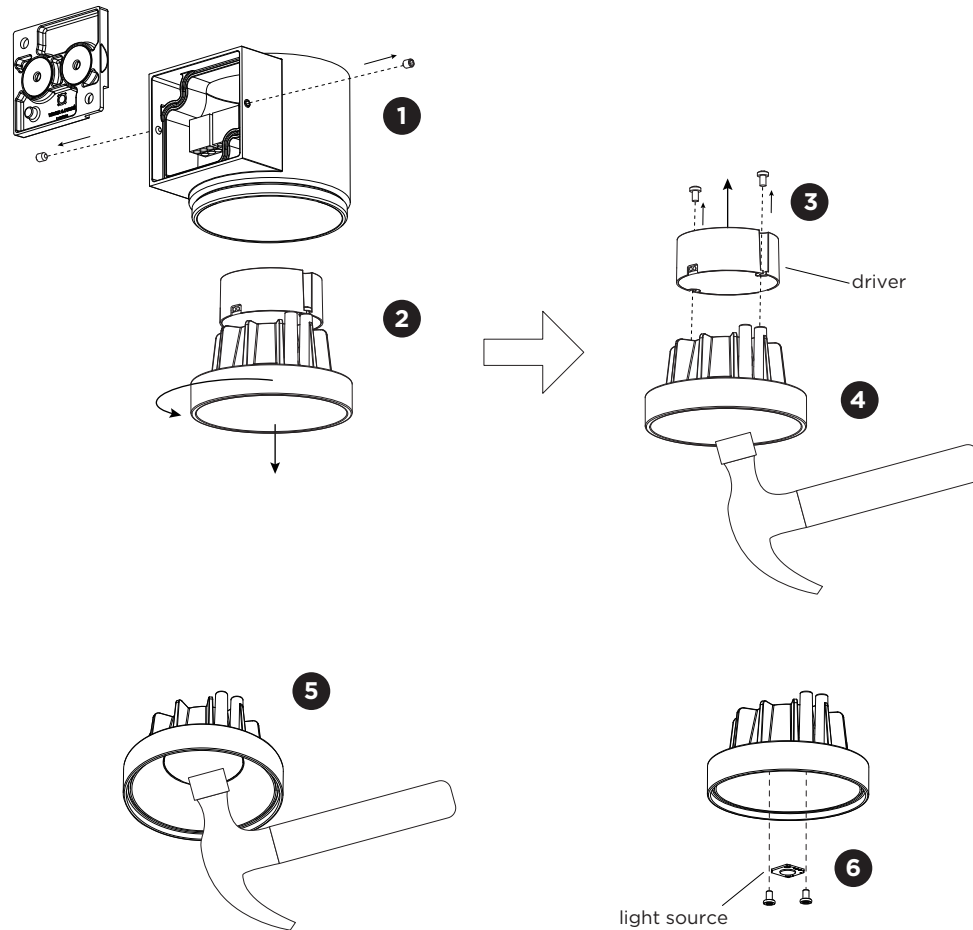

DISMANTLING AND RECYCLING INSTRUCTIONS

Light source & driver

- 1 Loosen the side screws and disconnect the cables to remove the lamp housing from the mounting base.
- 2 Turn and pull out the light body together with the driver.
- 3 Loosen the screws and cut the wires to remove the driver.
- 4 Break the glass.
- 5 Break the lens.
- 6 Unscrew the light source to remove it.

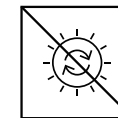

The light source is not replaceable.



The driver can be replaced by the end user.



This luminaire contains a light source with the energy class D.



WEVER & DUCRÉ
LIGHTING

WEVER & DUCRÉ BV
Spinnerijstraat 99/21, 8500 Kortrijk, Belgium
weverducre.com