

Led 120

TUNTO LIGHTING
Tekijänkatu 8,
FI-04440 Järvenpää, Finland
Tel. +358 10 421 3000
mail@tunto.com



ENGLISH - CAUTION!

Always shut off power to the circuit before starting installation work. Install in accordance with national electrical codes. All installation works must be performed by an authorized electrical contractor. Contact your local electricity authority for advice.

- For indoor use only, excluding bathrooms and humid spaces.
- Always choose the most suitable fasteners and fixing tools for the ceiling or wall material.
- Cleaning with slightly damp cloth.
- In case of malfunction or damage, please contact the retailer.

DUTCH - VOORZICHTIGHEID!

Schakel altijd eerst de stroom uit voordat met de installatie begonnen wordt. Installeer in overeenstemming met de nationale elektrische voorschriften. Alle elektrische installaties moeten worden uitgevoerd door een bevoegd elektricien. Neem daarom contact op met de plaatselijke overheid voor advies.

- Alleen voor gebruik binnenshuis, met uitzondering van badkamers en vochtige ruimtes.
- Kies altijd de meest geschikte bevestigingsmiddelen en gereedschap voor het plafond- of wandmateriaal.
- Reinigen met een licht vochtige doek.
- In geval van storing of schade, neem dan contact op met de winkelier.

FRANÇAIS - ATTENTION!

Toujours couper l'alimentation au panneau principal avant de procéder à l'installation. Installer conformément aux réglementations électriques nationales. L'installation doit être effectuée par un électricien qualifié. Pour en savoir plus, contactez les autorités locales compétentes en la matière.

- Pour une installation en intérieur à l'exception des salles de bains et pièces humides.
- Pour installer le luminaire utilisez des éléments de fixation adaptés au support.
- Pour nettoyer le luminaire utilisez un chiffon en coton légèrement humide.
- En cas d'incident ou de défaillance du luminaire contactez directement le revendeur.

SUOMI - TÄRKEÄÄ!

Kytke virta pois pääkatkaisimesta aina ennen asennuksen aloittamista. Asennettava paikallisten sähkömääräysten mukaisesti. Asennuksen saa suorittaa vain ammattitaitoinen sähköasentaja. Ota selvää paikallisista määräyksistä.

- Tuote soveltuu vain kuiviin sisätiloihin.
- Valitse aina sopivin mahdollinen kiinnitystapa katon tai seinän materiaalille.
- Puhdistus kostealla pehmeällä liinalla.
- Ongelmatilanteissa ole yhteydessä tuotteen myyjään.

DEUTSCH - VORSICHT!

Vor der Installation den Strom abschalten. Installieren Sie das Gerät gemäß den örtlichen elektrischen Vorschriften. Elektroinstallationen dürfen nur von autorisierten Elektrofachleuten ausgeführt werden. Im Zweifelsfall die örtlichen Behörden kontaktieren.

- Der Gebrauch dieser Leuchte ist ausschließlich in trockenen Innenbereichen vorgesehen und nicht in Bädern oder anderen feuchten Räumen.
- Wählen Sie für die Montage die geeigneten Befestigungsmittel.
- Zur Reinigung der Leuchte ein leicht angefeuchtetes Tuch verwenden.
- Im Falle einer Fehlfunktion der Leuchte bitte den Fachhändler kontaktieren.

ESPAÑOL - PRECAUCIÓN!

Desconectar siempre el interruptor general de la electricidad antes de iniciar cualquier trabajo de instalación. Instalar de acuerdo con las regulaciones eléctricas nacionales. La instalación eléctrica sólo puede realizarla un electricista profesional. Contactar con las autoridades locales para asesoramiento.

- Esta luminaria es apta únicamente para uso interior, excepto baños o cualquier tipo de superficie húmeda.
- Para el montaje de la luminaria a la pared elegir los elementos de fijación mas adecuados en función del soporte de instalación.
- Para limpiar la luminaria, usar un paño ligeramente húmedo.
- En caso de incidente, contactar directamente con el establecimiento dónde se adquirió.

ITALIANO - ATTENZIONE!

Prima di iniziare l'installazione staccare sempre la corrente al circuito. Installare secondo il codice elettrico nazionale. L'installazione elettrica può essere effettuata solo da un elettricista autorizzato. Per avere ulteriori informazioni, contatta l'autorità elettrica locale.

- Questo apparecchio è adatto solo per uso interno ad eccezione di bagni o altri luoghi umidi.
- Per il montaggio usare gli strumenti di fissaggio più adeguati in base al tipo di materiale della parete.
- Per la pulizia usare un panno di cotone leggermente umido.
- In caso di malfunzionamento o difetto rivolgersi direttamente al rivenditore.

SVENSKA - VIKTIGT!

Stäng alltid av strömmen innan installation påbörjas. Installera i enlighet med lokala elektriska koder. Elektrisk installation får endast utföras av auktoriserad elektriker. Kontakta din lokala myndighet för råd.

- Använd endast i torra interiörer.
- Välj alltid den lämpligaste fästmetoden för det vägg- eller takmaterialet.
- Rengöring med en fuktig handduk.
- Kontakta säljaren vid problem.

1

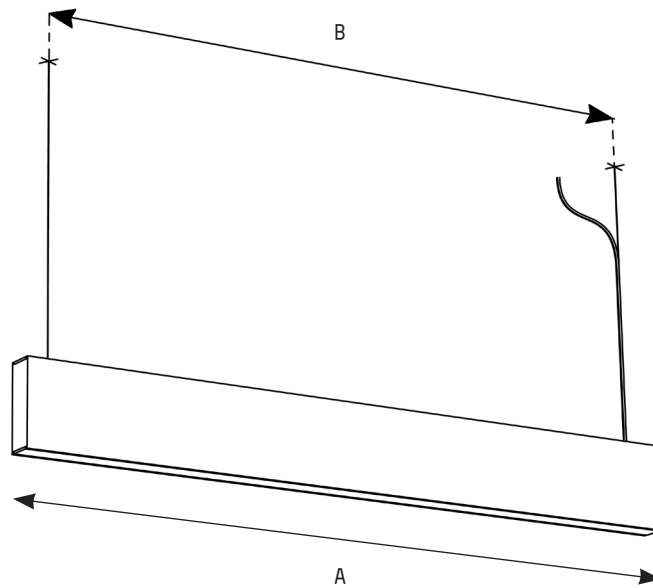

A	B
700 mm	620 mm
1000 mm	920 mm
1300 mm	1220 mm
1600 mm	1520 mm

2

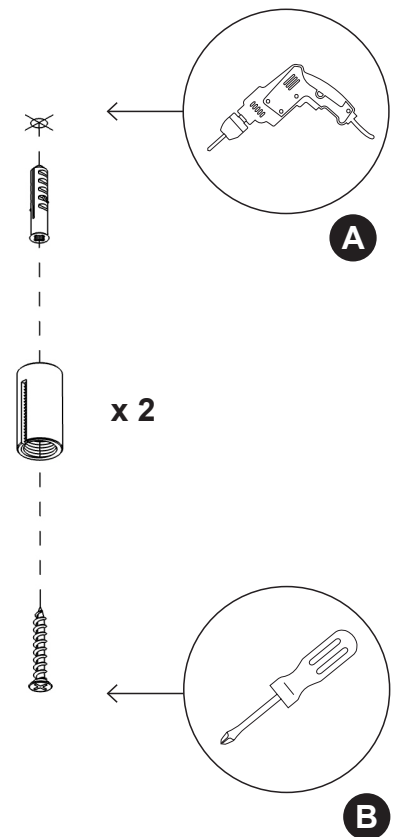
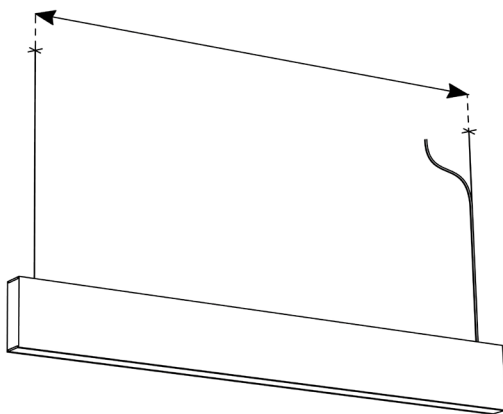
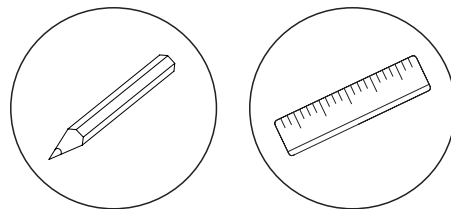

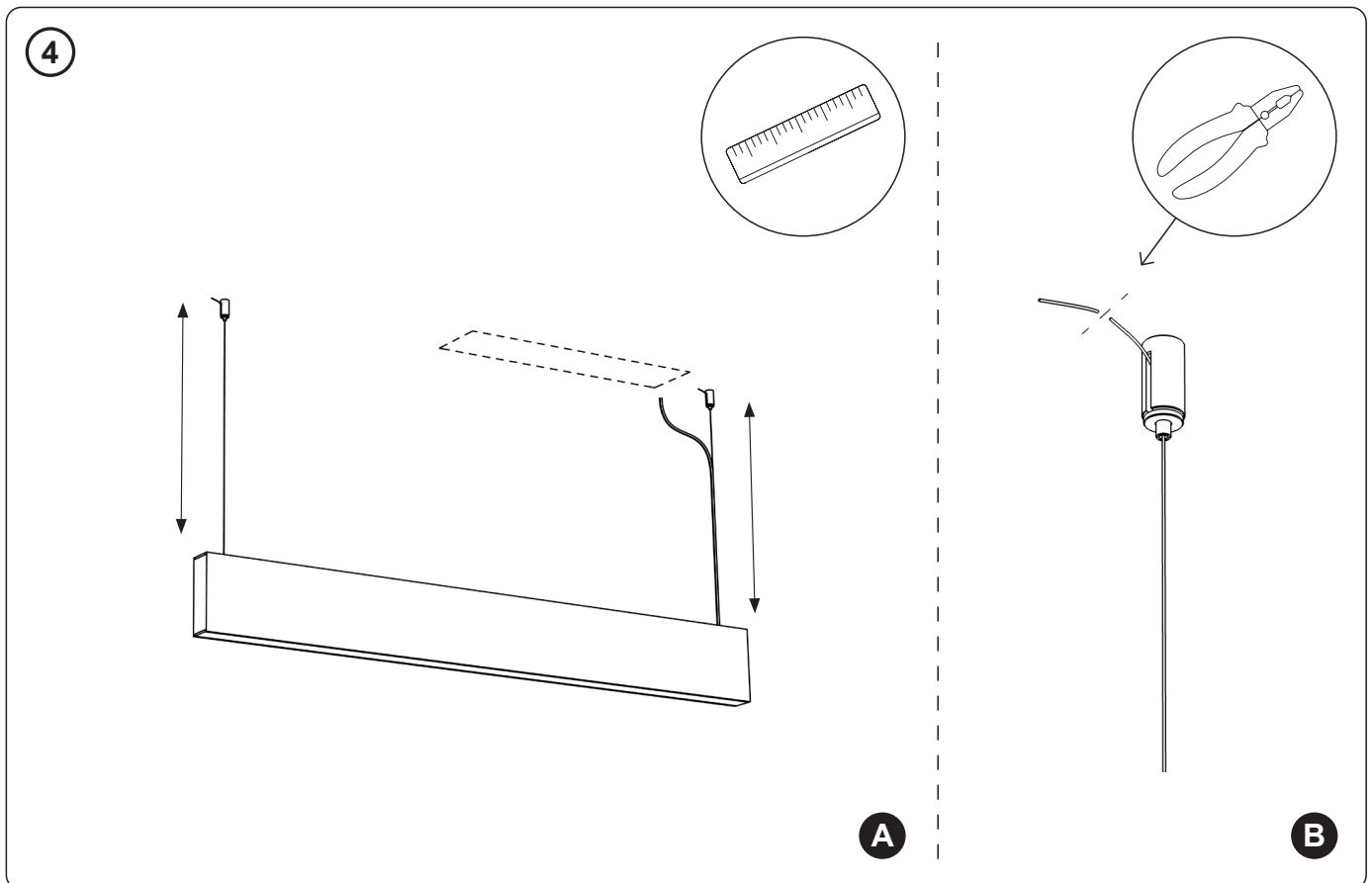
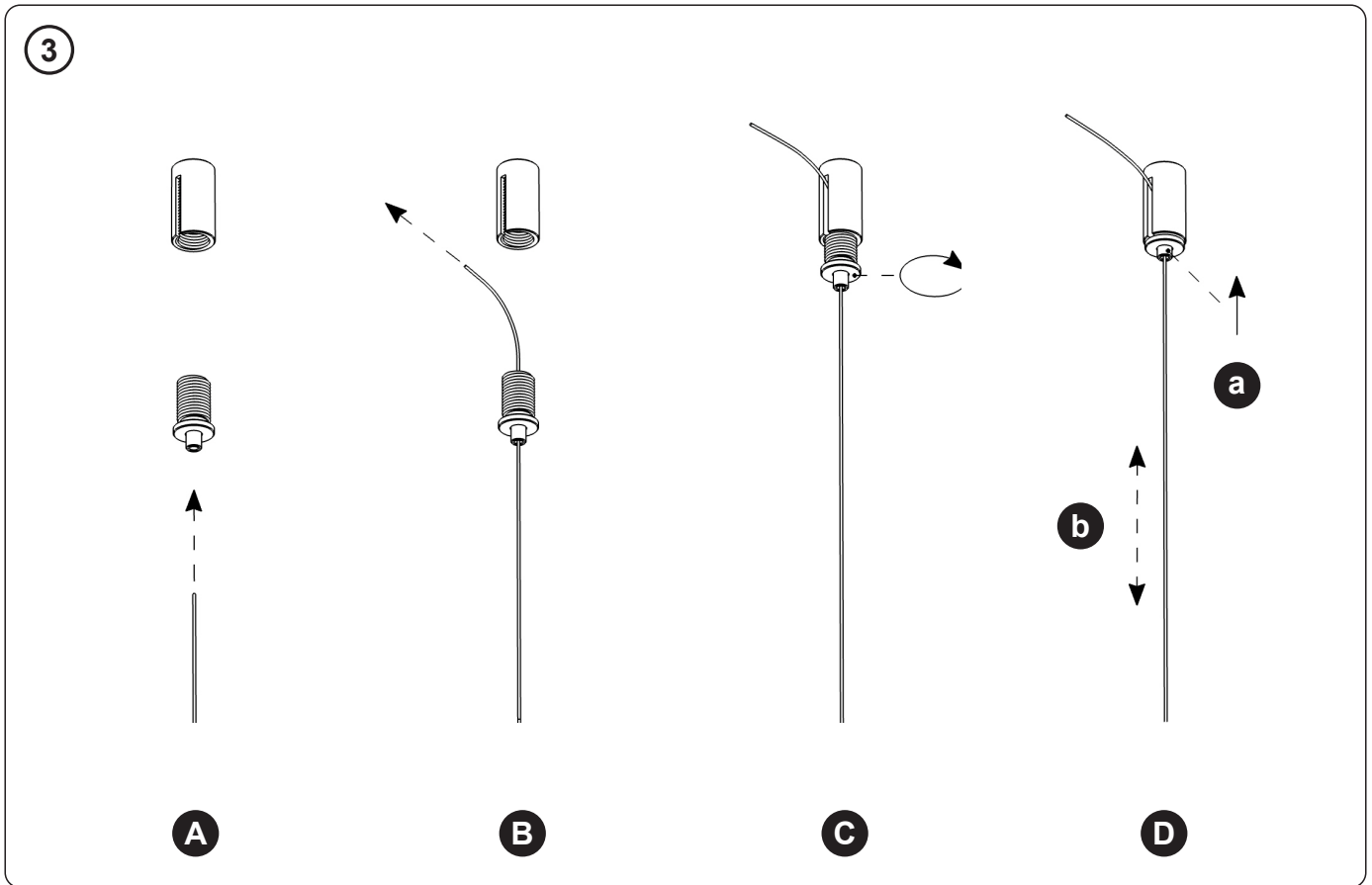

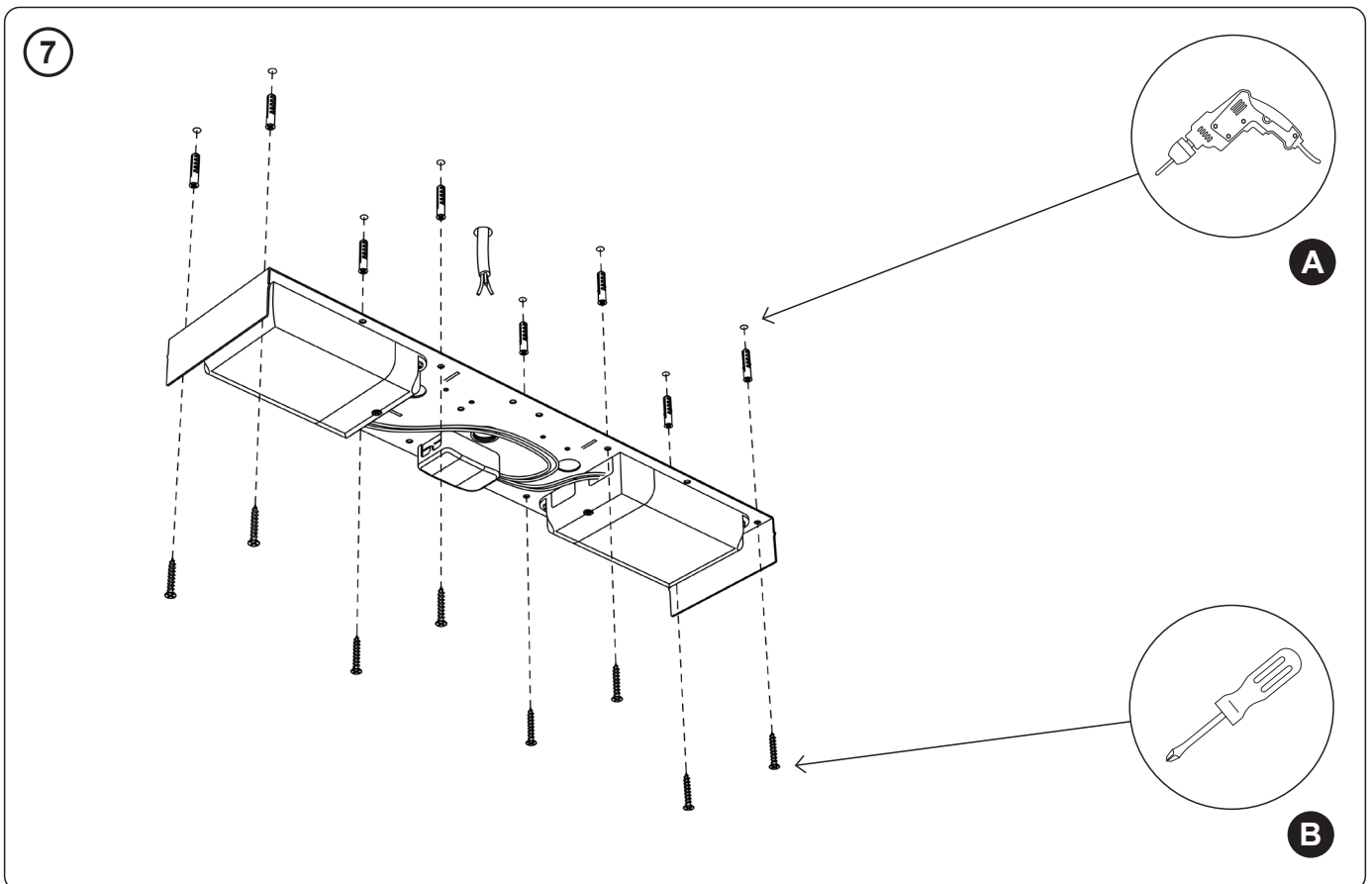
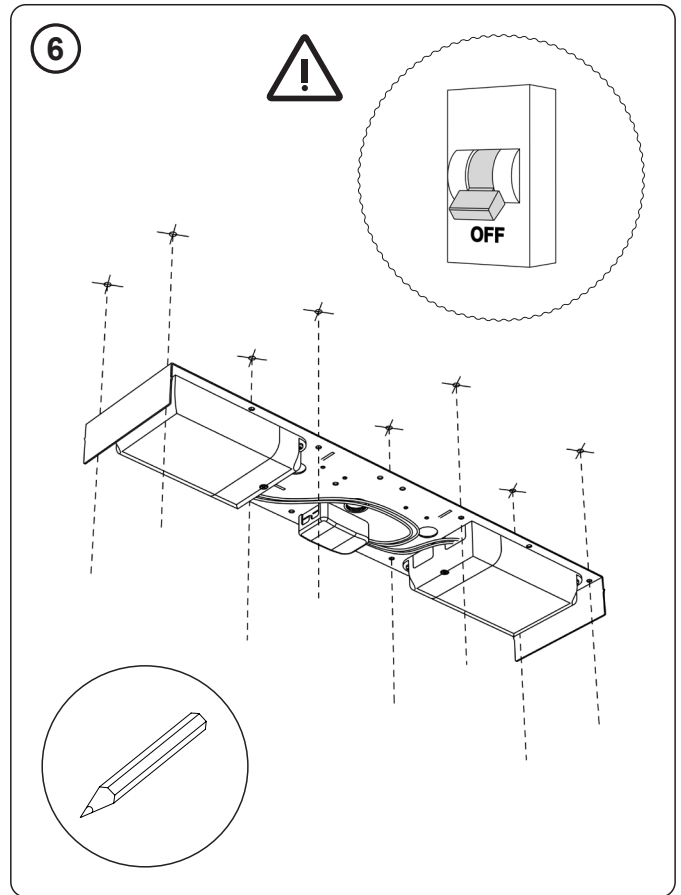
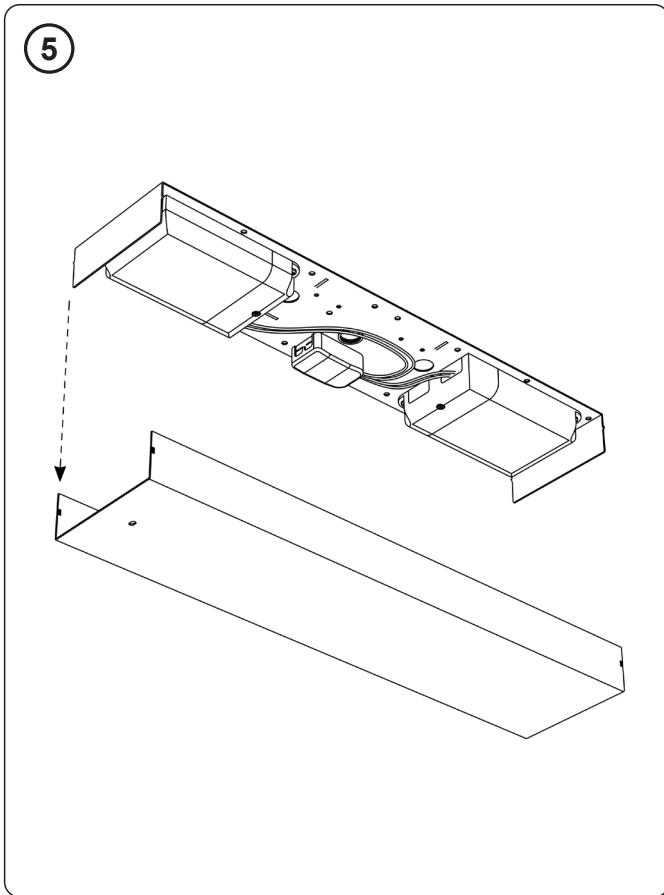

8

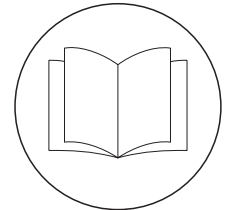
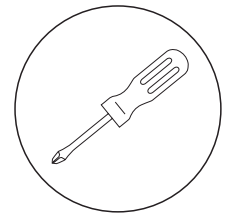
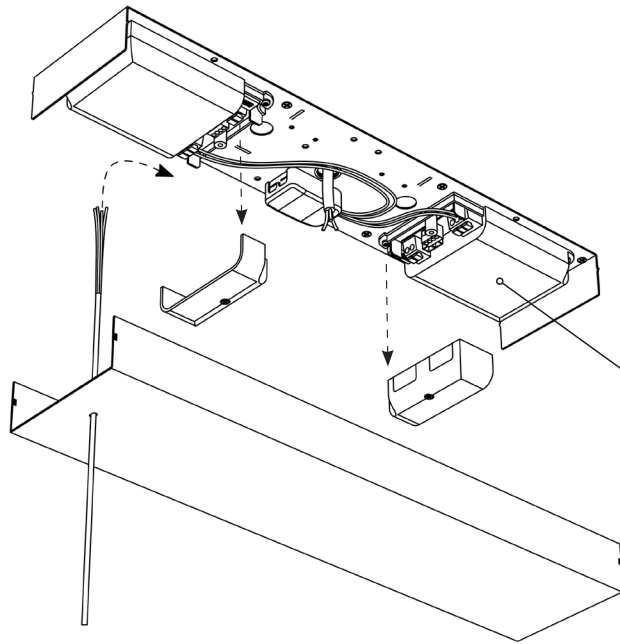

no.	LED POWER
A	DALI, PUSH DIM
B	0-10V / PWM
C	CASAMBI DIM
D	TRIAC
E	ANALOG DIM
F	NORTH AMERICA

9

