

# VIBIA

Assembly instructions / Instrucciones de montaje / Montageanleitung  
Istruzioni di montaggio / Instructions de montage

## Dots

Design by Martin Azúa



## Caution

Before assembling and installing this product, carefully read the following:

- Switch of the mains before installing the lamp.
- To install on the ground, always choose the most adequate fixing tools for the ground material.
- Before installing the lamp into the ground make sure the destination surface will not be permanently damaged. If this happens, it will be the installer's responsibility.
- We recommend reading the manual before installing the lamp. Keep this instructions for future reference.
- Do not disassemble, modify or try to repair this fitting. In order to get technical assistance contact VIBIA. Any change or modification to the light fitting can null the manufacturer's guarantee.
- All electronic products and batteries must be taken to separate waste collection points at the end of their working lives, they must not be disposed of in normal household waste. It is the responsibility of the user to dispose of the equipment using a designated collection point or service for separate recycling of waste electrical and electronic equipment (WEEE) and batteries according to local laws.



## Precaución

Antes de proceder al montaje e instalación de esta luminaria, leer detenidamente las siguientes consideraciones:

- Desconectar el suministro eléctrico antes de proceder a la instalación de la luminaria.
- Para el montaje de la luminaria al suelo elegir los elementos de fijación más adecuados en función del soporte de instalación.
- Asegurarse antes de realizar la operación de fijar la luminaria al suelo, que en el soporte de instalación no se produzcan daños irreparables. En caso contrario la responsabilidad será del instalador.
- Recomendamos leer el manual antes de iniciar la instalación de la luminaria. Guardar estas instrucciones para futuras consultas.
- No desmonte, modifique, ni intente reparar la luminaria. Para recibir asistencia técnica, pongase en contacto con VIBIA. Cualquier cambio o modificación en la luminaria puede anular la garantía del fabricante.
- Todos los productos electrónicos y las baterías deben llevarse a puntos de recolección de residuos separados cuando finalicen sus ciclos de vida, no se deben desechar en la cadena normal de residuos con la basura doméstica. Es responsabilidad del usuario desechar los dispositivos en un punto o servicio de recolección designado para el reciclaje separado de residuos de aparatos eléctricos y electrónicos (WEEE), así como las baterías, de conformidad con las leyes locales.

## Vorsicht

Bevor Sie mit der Montage dieser Leuchte beginnen, sollten Sie die folgenden Hinweise in aller Ruhe lesen und berücksichtigen:

- Schalten Sie vor dem elektrischen Anschluss den Strom ab.
- Wählen Sie passend zu der Vorrichtung für die Befestigung am Boden der Leuchte das dafür geeignetste Befestigungsmaterial.
- Vergewissern Sie sich vor der Installation der Leuchte, dass es sich um eine geeignete Stelle handelt und nicht dauerhaft beschädigt wird. Falls doch, trägt hierfür der Installateur die Verantwortung
- Wir empfehlen vor Montagebeginn die Anleitung zu lesen. Bewahren Sie die Anleitung für etwaige zukünftige Fragen auf.
- Die Leuchte nicht auseinanderbauen, baulich ändern oder reparieren. Für technische Hilfe VIBIA kontaktieren. Eigenmächtig vorgenommene Änderungen an der Leuchte führen zu einem Verlust der Garantie.
- Alle elektronischen Produkte und Batterien am Ende Ihrer Lebensdauer getrennt entsorgt werden müssen, sie dürfen nicht über den normalen Fluss des Haushaltsmülls entsorgt werden. Es unterliegt der Verantwortlichkeit des Benutzers, die Ausrüstung unter Verwendung einer ausgewiesenen Sammelstelle oder eines Dienstes für getrenntes Recycling von elektrischen oder elektronischen Geräten und Batterien entsprechend der Gesetzgebung vor Ort zu entsorgen (WEEE = Waste of Electrical and Electronic Equipment = Elektro - und Elektronikgeräte - Abfall).

## Attention

Prima di procedere al montaggio e all'installazione di questo apparecchio, leggere attentamente le seguenti considerazioni:

- Scollegare l'alimentazione prima di procedere all'installazione dell'apparecchio.
- Per il montaggio della lampada a terra, usare gli strumenti di fissaggio più adeguati in base alla superficie di installazione.
- Prima di eseguire l'operazione di fissaggio della lampada a terra, assicurarsi che la superficie di installazione sia adatta allo scopo e non venga danneggiata irreparabilmente. In caso contrario, la responsabilità sarà del montatore.
- Si consiglia di leggere il manuale prima di iniziare l'installazione dell'apparecchio. Salva queste istruzioni per future consultazioni.
- Non smontare, modificare né cercare di riparare la lampada. Per richiedere assistenza tecnica, mettersi in contatto con VIBIA. Qualsiasi cambiamento o modifica alla lampada può annullare la garanzia del fabbricante.
- Tutti i prodotti elettronici e le batterie devono essere separate in punti di raccolta dei rifiuti una volta terminato l'utilizzo, non devono essere smaltiti nel normale flusso dei rifiuti insieme ai rifiuti domestici. È responsabilità dell'utente smaltire l'apparecchiatura utilizzando un punto di raccolta o un servizio per il riciclo di apparecchiature elettriche ed elettroniche (RAEE) e batterie secondo le leggi vigenti.

## Attenzione

Avant de procéder à l'assemblage et à l'installation de ce luminaire, lisez attentivement les considérations suivantes:

- Débranchez l'alimentation avant de procéder à l'installation du luminaire.
- Pour fixer le luminaire au sol, utilisez les éléments de fixation les mieux adaptés au support.
- Avant de procéder à la fixation du luminaire au sol, assurez-vous que le support d'installation ne subira aucun dommage irréversible. Dans le cas contraire, la responsabilité des dommages incombera à l'installateur.
- Nous vous recommandons de lire le manuel avant de commencer l'installation du luminaire. Sauvegardez ces instructions pour futures consultations.
- Ne démontez pas le luminaire, ne le modifiez pas et n'essayez pas de le réparer. Pour bénéficier d'une assistance technique, contactez VIBIA. Toute altération ou modification du luminaire peut annuler la garantie du fabricant.
- Tous les produits électroniques et toutes les batteries doivent être apportés à des points de collecte distincts de ceux des ordures ménagères normales lorsqu'ils arrivent en fin de vie. Il incombe à l'utilisateur de se débarrasser de l'équipement dans un point de collecte ou auprès d'un service spécifiquement désigné pour le recyclage des déchets électriques et des équipements électroniques (DEEE) ainsi que des batteries, dans le respect de la législation locale.



**Step 1**  
Product Spec Sheet



**Step 2**  
Supplied Materials



**Step 3**  
Installation Preparation



**Step 4**  
Electrical Connection



**Step 5**  
Product Assembly







Step 1/5



# Product Spec Sheet

Technical specifications / Especificaciones técnicas / Technische Daten  
Specifiche tecniche / Caractéristiques techniques

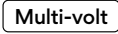



## 4695

Net Weight / Peso Neto / Netto-Gewicht 2,70 kg.  1 x LED STRIP 7,8W 350mA     ~ 50/60 Hz  
Peso netto / Poids net

## 4697

Net Weight / Peso Neto / Netto-Gewicht 1,50 kg.  1 x LED STRIP 4,6W 350mA     ~ 50/60 Hz  
Peso netto / Poids net

## 4700

Net Weight / Peso Neto / Netto-Gewicht 3,10 kg.  1 x LED STRIP 14,8W 350mA     ~ 50/60 Hz  
Peso netto / Poids net

## 4702

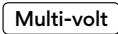
Net Weight / Peso Neto / Netto-Gewicht 1,50 kg.  1 x LED STRIP 12,8 W 300mA     ~ 50/60 Hz  
Peso netto / Poids net



**Class I.** Product with an additional protection cable (grounds).

**Clase I.** Aparato con un cable protector adicional (toma de tierra).

**Klasse I.** Apparat mit zusätzlichen Schutzleiter (Erdkabel).

**Classe I.** Apparecchio con un cavo di protezione aggiuntivo (presa di terra).

**Classe I.** Appareil avec câble d'isolation additionnel (borne de terre).

**IP65**

Dust-tight product. Protected against water trickles.

Producto totalmente estanco al polvo. Protegido contra los chorros de agua.

Staubdicht. Schutz gegen das Eindringen von Strahlwasser.

Prodotto antipolvere. Protetto contro i rivoli d'acqua.

Totalement protégé contre les poussières. Protégé contre les jets d'eau de toutes directions à la lance.

**Bi-volt**

Rango de voltaje:

Voltage range:

Spannungsbereich:

Campo di tensione:

Gamme de tension:

100-240V

**Multi-volt**

Rango de voltaje:

Voltage range:

Spannungsbereich:

Campo di tensione:

Gamme de tension:

100-277V



Step 2/5

## Supplied Materials

Supplied material / Material suministrado / Geliefertes Material  
Materiale incluso / Matériel fourni

	4695	4697	4700	4702
1. Allen key / Llave allen / Inbusschlüssel / Chiave a brugola / Clé Allen	1 un.	1 un.	1 un.	1 un.
2. Lighting fixture / Estructura luminaria / Leuchtenstruktur / Struttura lampada / Structure du luminaire	1 un.	1 un.	1 un.	1 un.
3. Waterproof Case / Caja estanca / Wasserdichtes Gehäuse Scatola impermeabile / Boîtier étanche	1 un.	1 un.	1 un.	1 un.

1



2

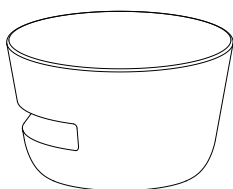

4695

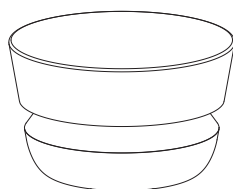

4700



4697



4702

3

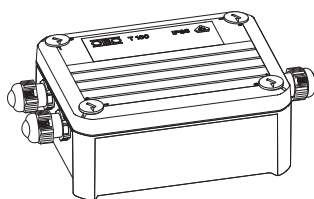

Only for DALI &  
Casambi models

### OPTION A: SINGLE CONNECTION

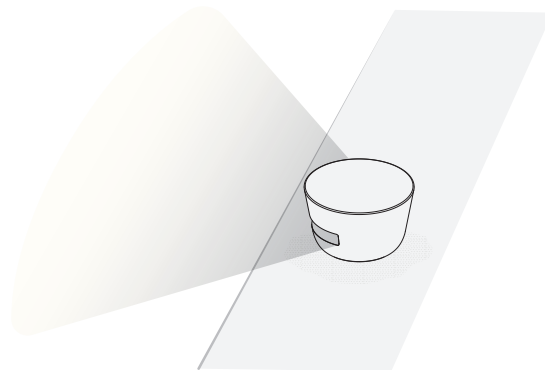

---

### OPTION B: PARALLEL CONNECTION

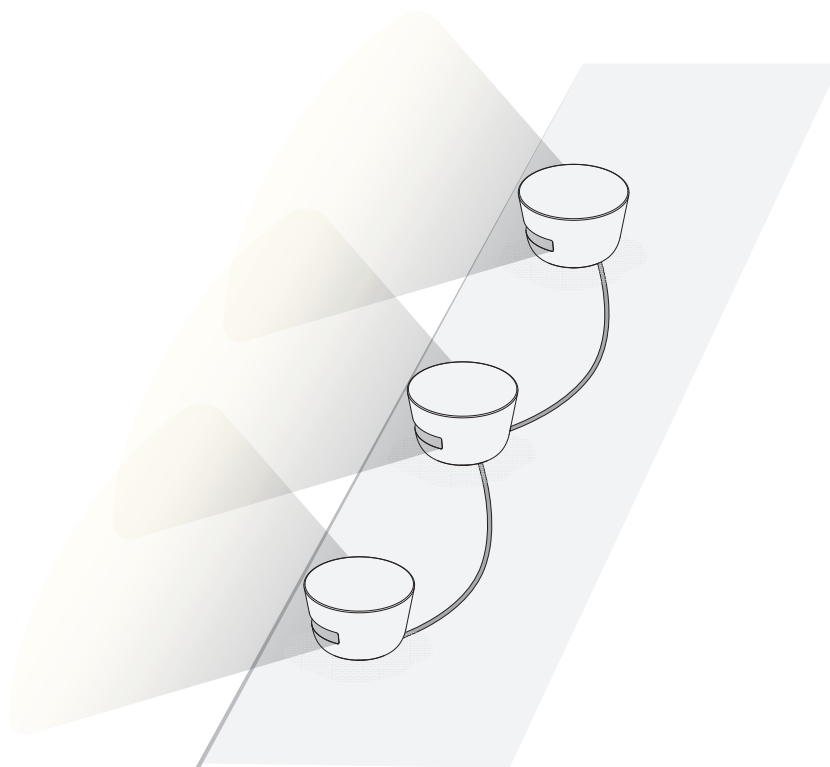



Step 3/5  
Installation Preparation

3.1

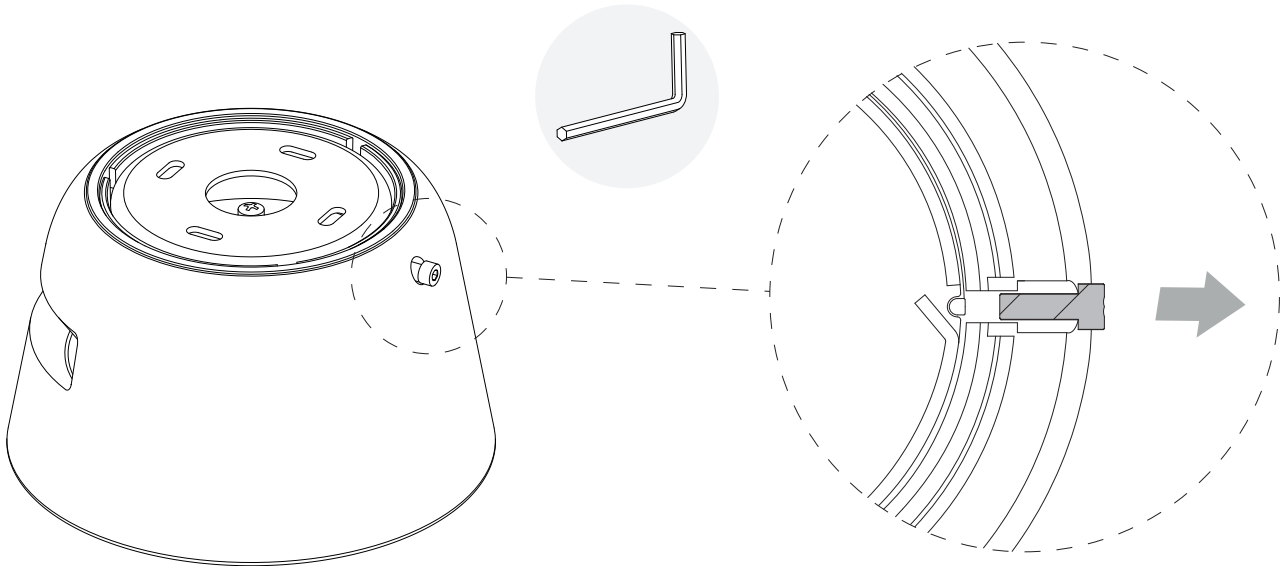

3.2

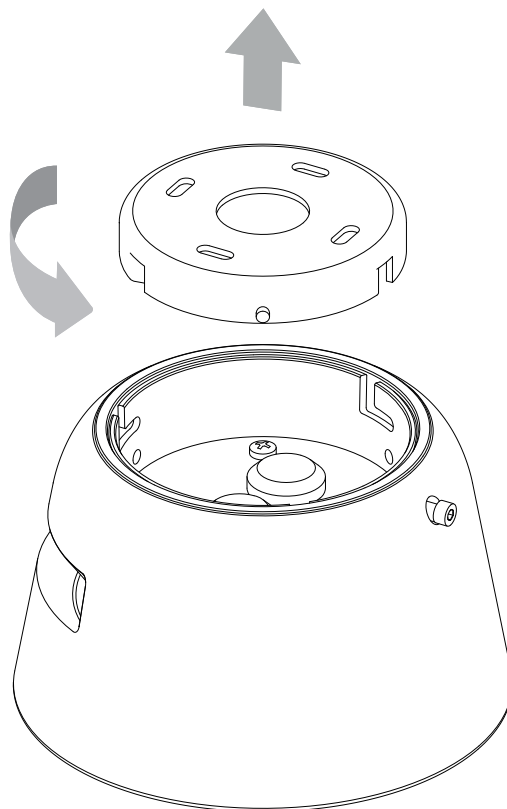



## Step 3/5 Installation Preparation

3.3

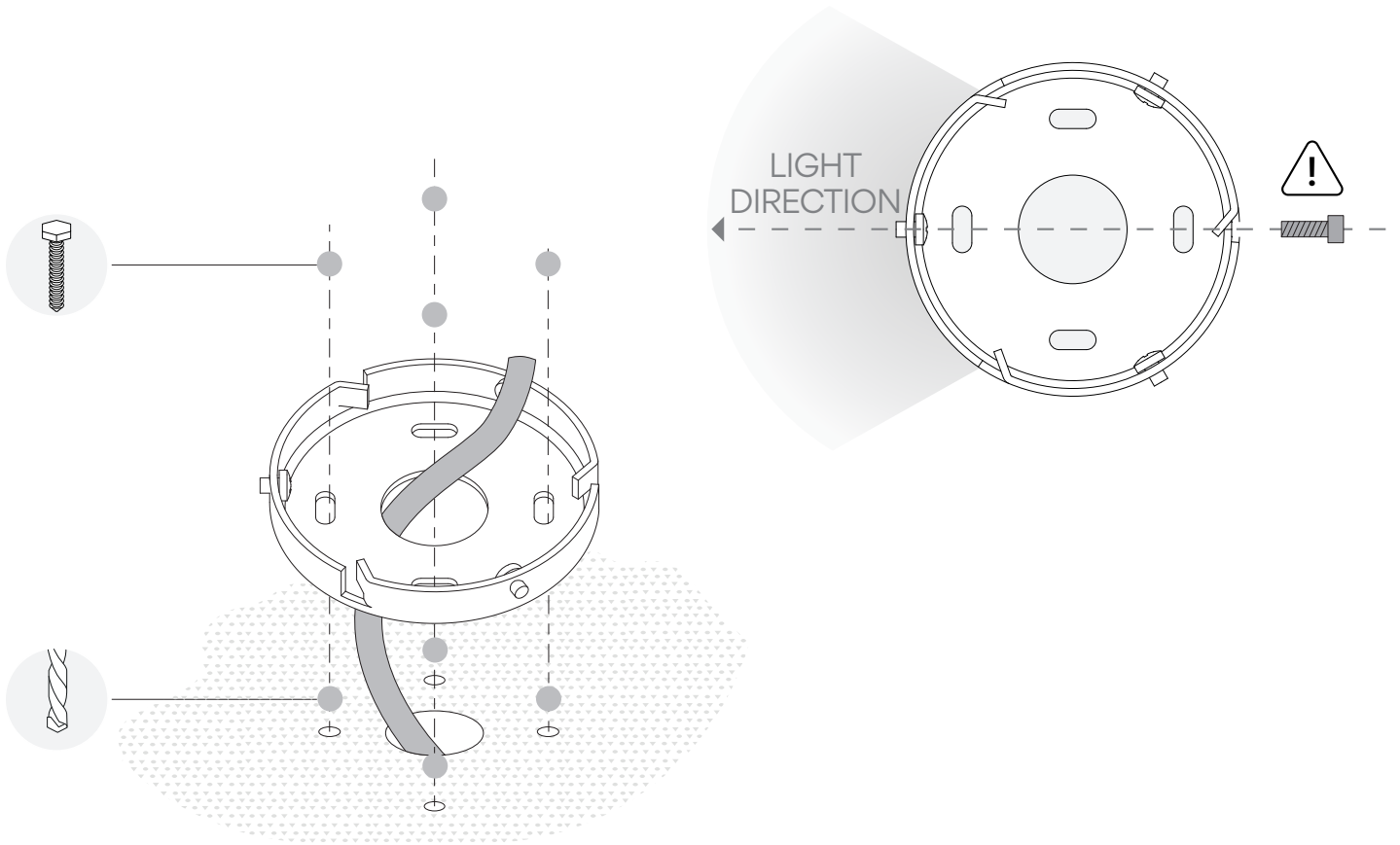

3.4

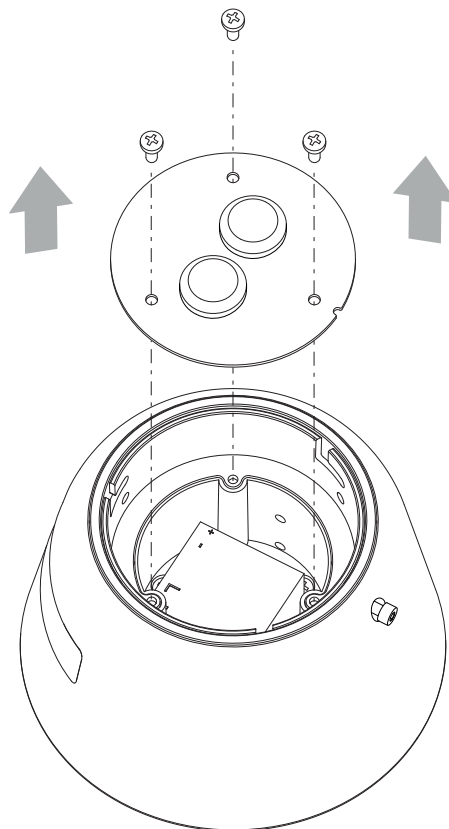





# Step 4/5 Electrical Connection

4.1A

## ON/OFF CONNECTION

Ref. 4697 / Ref. 4702

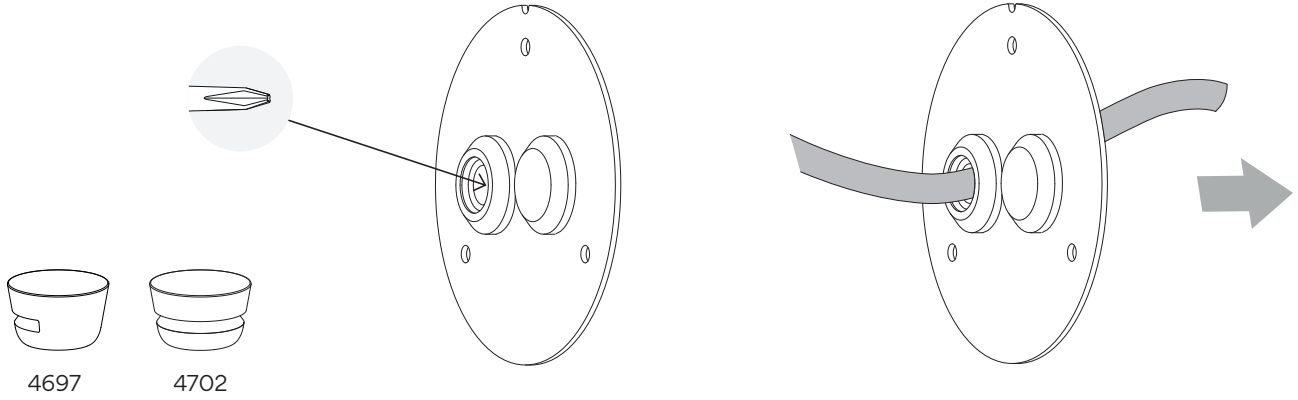

Ref. 4695 / Ref. 4700

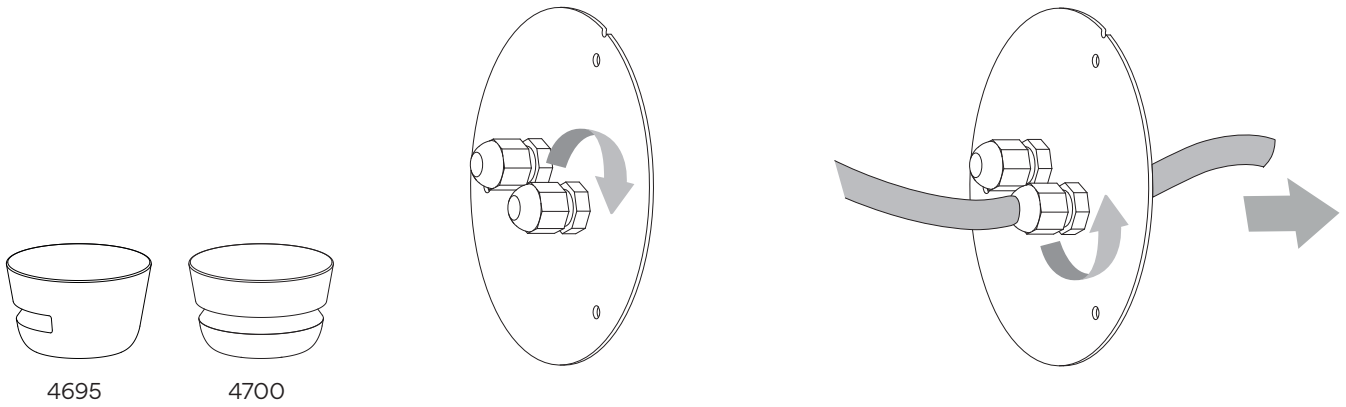

4.2

### OPTION A: SINGLE CONNECTION

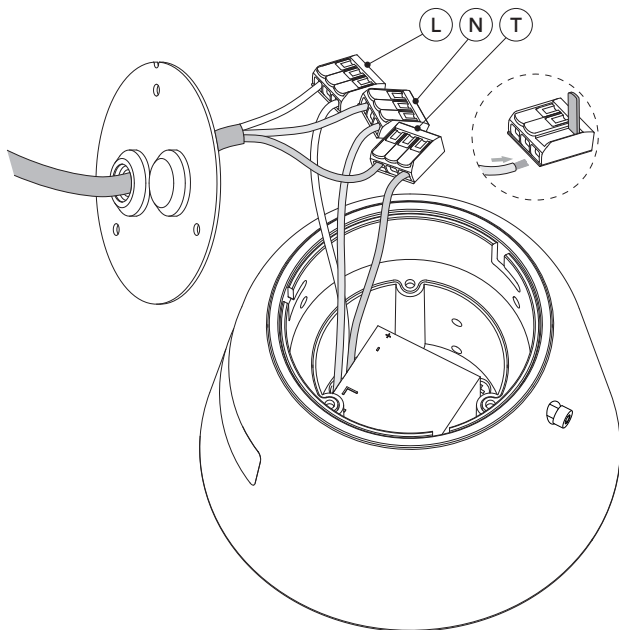

### OPTION B: PARALLEL CONNECTION

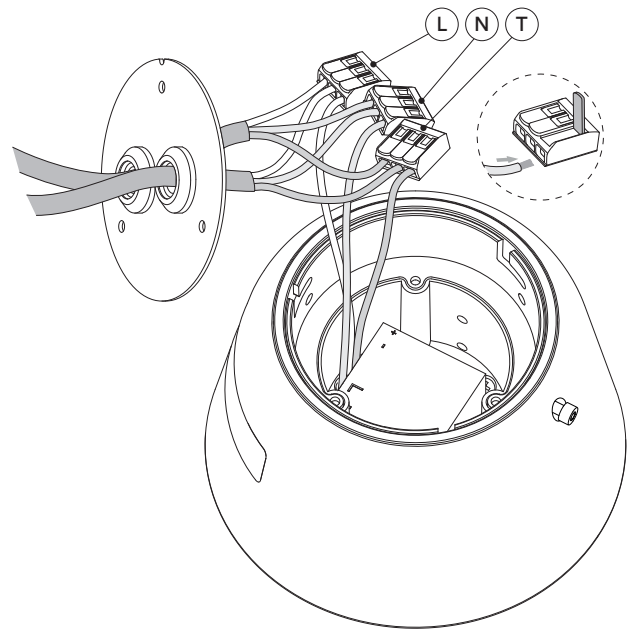



## Step 4/5 Electrical Connection

### 4.1B DALI & CASAMBI CONNECTION WITH REMOTE WATERTIGHT BOX

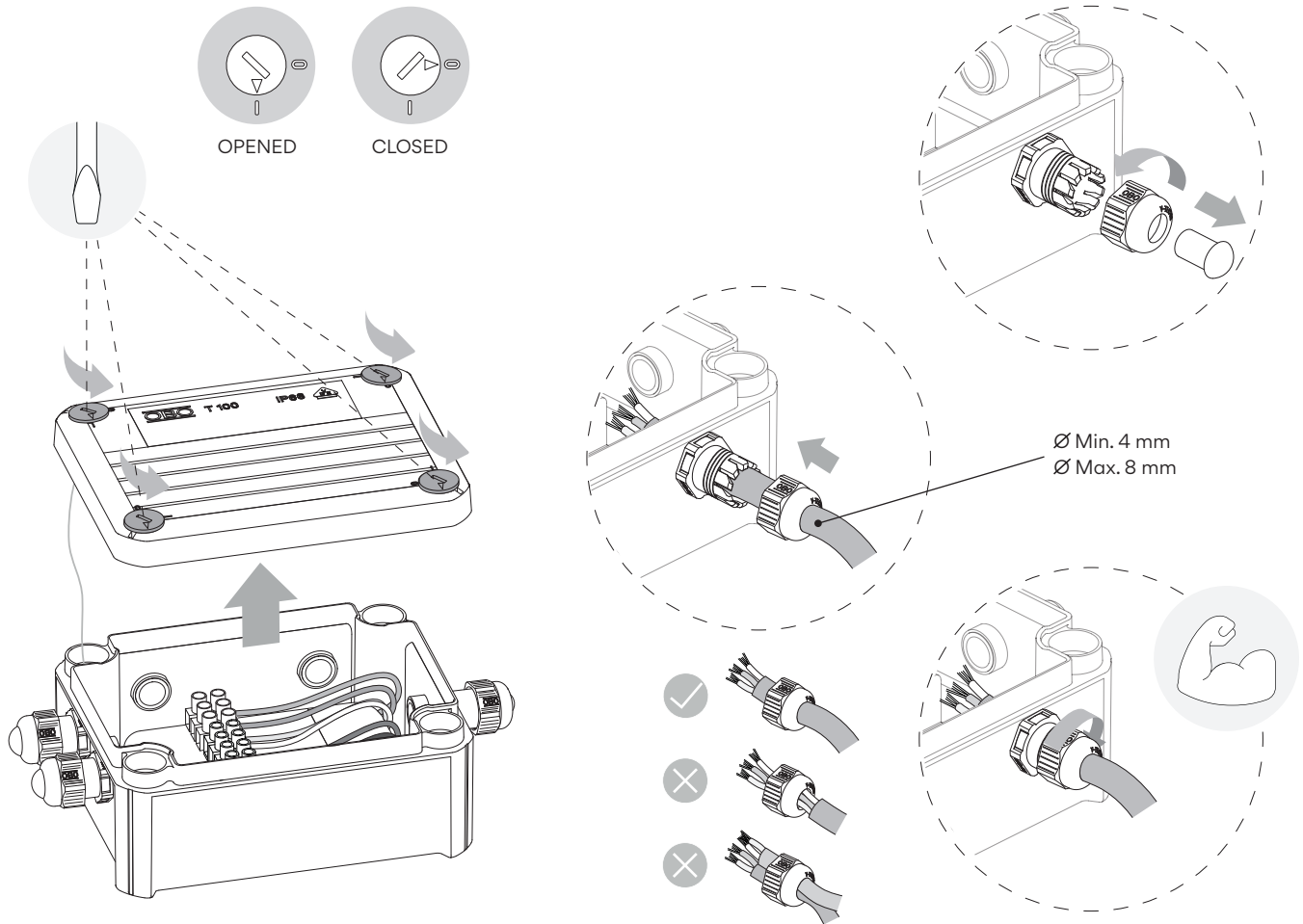

#### DALI SYSTEM DIMMING

Refs.:  
4695XX/11  
4697XX/11  
4700XX/11  
4702XX/11

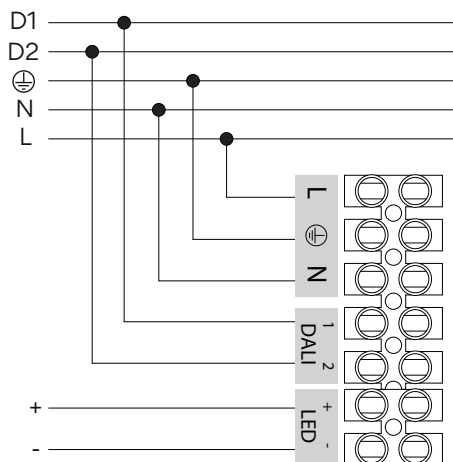

- Only for product references ending in 1
- Solo para los productos terminados en 1
- Nur für Produkte, die auf 1 enden
- Solo per i prodotti che terminano con 1
- Uniquement pour les produits terminés en 1

#### CASAMBI SYSTEM DIMMING

Refs.:  
4695XX/1Z  
4697XX/1Z  
4700XX/1Z  
4702XX/1Z

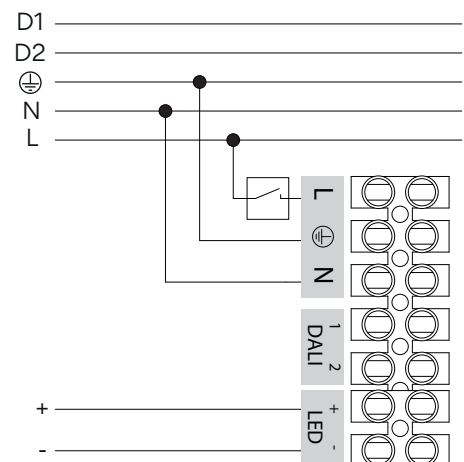

- Only for product references ending in Z
- Solo para los productos terminados en Z
- Nur für Produkte, die auf Z enden
- Solo per i prodotti che terminano con Z
- Uniquement pour les produits terminés en Z



## Step 4/5 Electrical Connection

### 4.2B

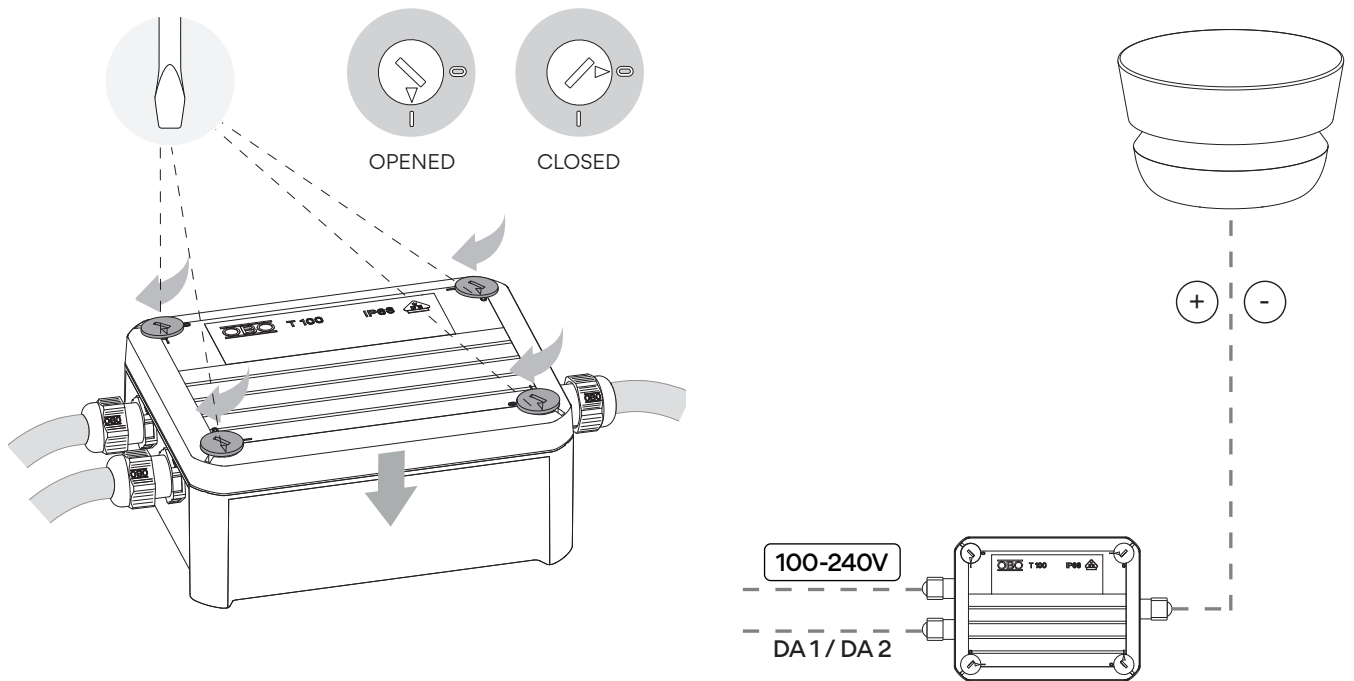

### 4.3B

Ref. 4697 / Ref. 4702

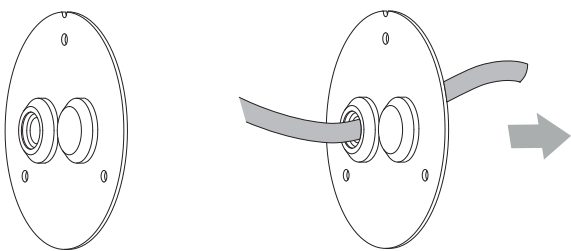

Ref. 4695 / Ref. 4700

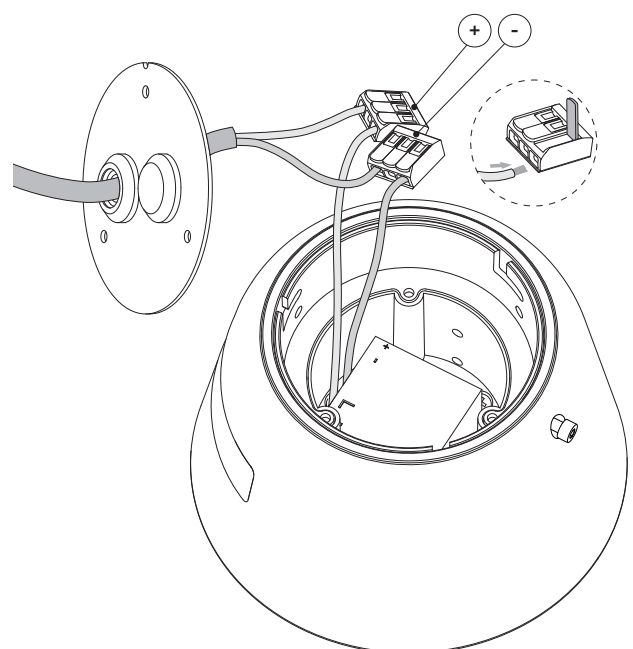
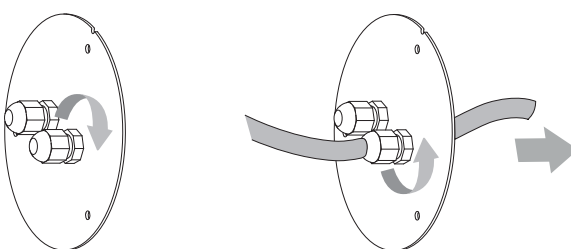



# Step 5/5 Product Assembly

5.1

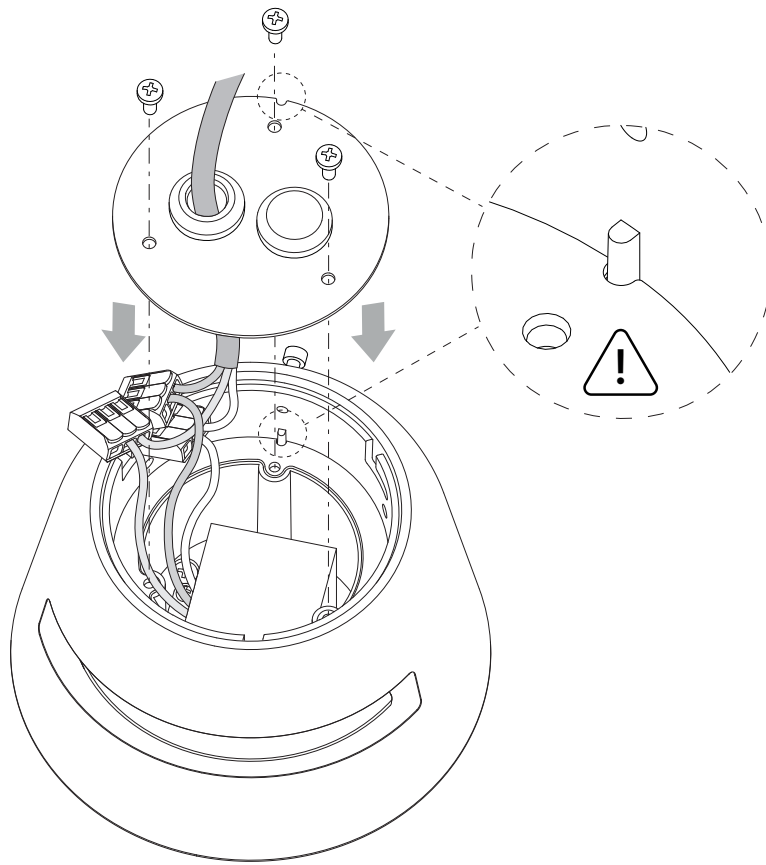

5.2

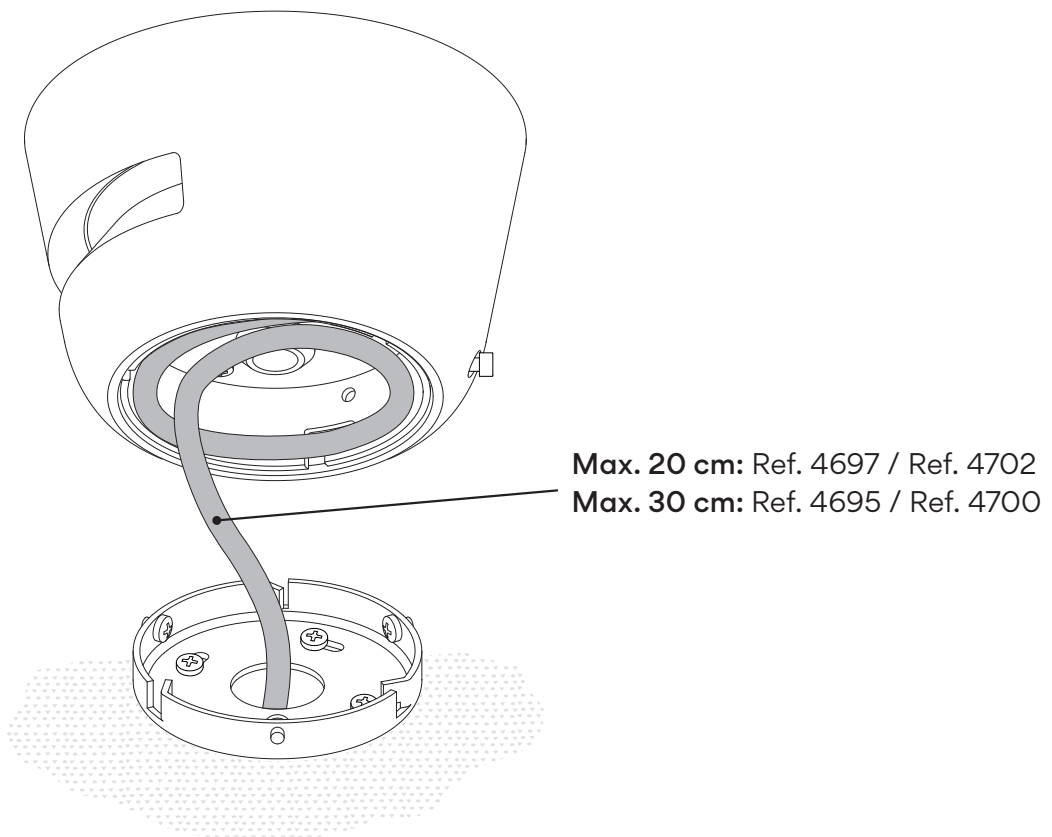



Step 5/5  
Product Assembly

5.3

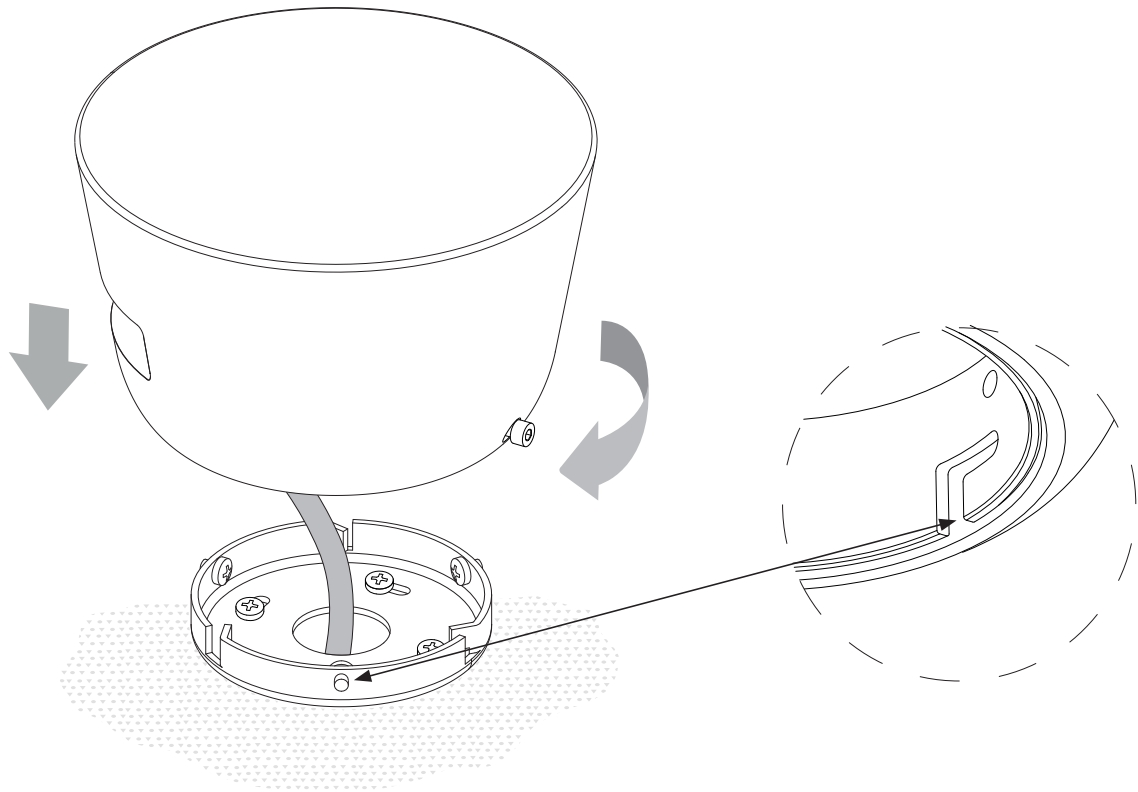

5.4

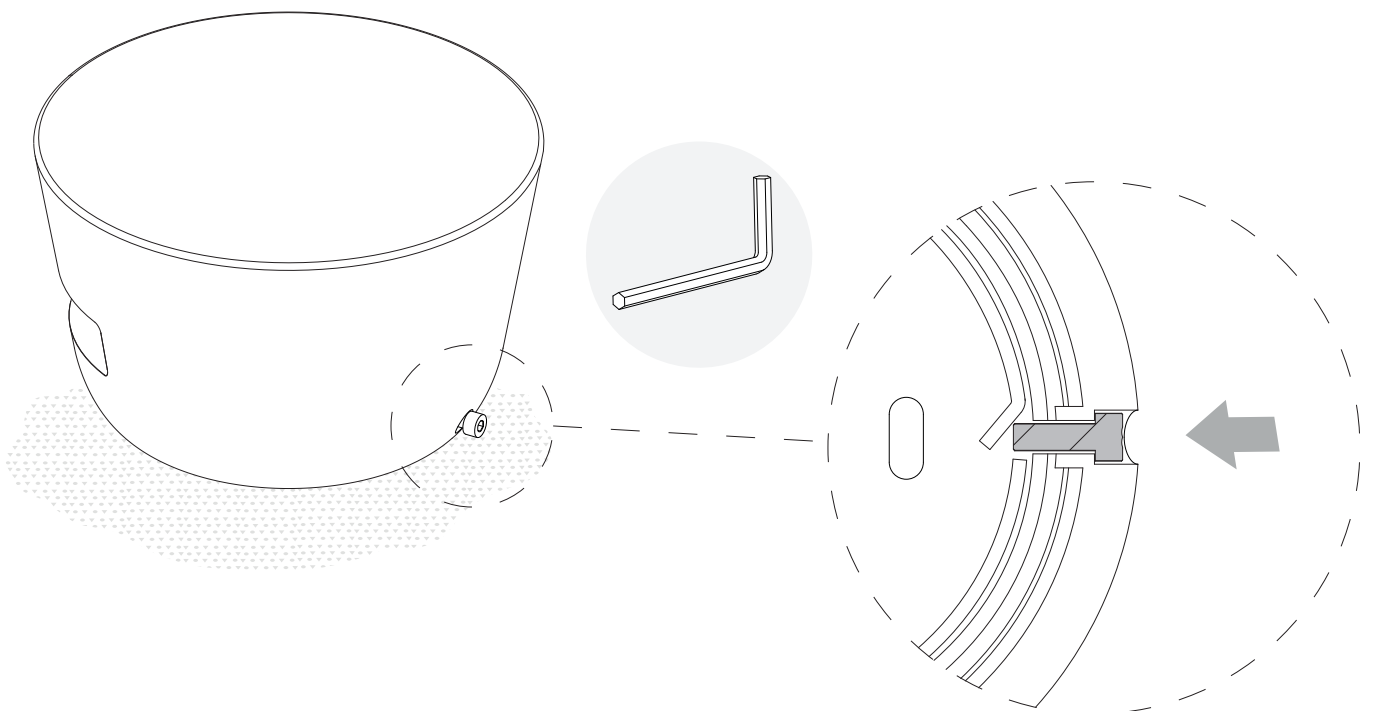

---

## Maintenance

Use a slightly-wet cotton cloth for cleaning.

In case of malfunction or damage, please contact the retailer who sold the lamp.

---

## Mantenimiento

Para limpiar la luminaria, usar un paño de algodón ligeramente humedecido en agua.

En caso de avería o incidente con la luminaria, contactar directamente con el establecimiento en que se adquirió.

---

## Instandhaltung

Zur Reinigung der Leuchte nutzen Sie einen leicht angefeuchteten Baumwoll-Lappen.

Im Falle des Ausfalls oder einer Fehlfunktion der Leuchte setzen Sie sich direkt mit dem Unternehmen in Verbindung bei dem Sie die Leuchte bezogen haben.

---

## Manutenzione

Per la pulizia della lampada, usare un panno di cotone leggermente inumidito con acqua.

In caso di guasto o incidente con la lampada, rivolgersi direttamente al rivenditore da cui è stata acquistata.

---

## Entretien

Pour nettoyer le luminaire, utilisez un chiffon en coton légèrement humidifié d'eau.

En cas d'incident ou de défaillance du luminaire, contactez directement l'établissement où vous l'avez acheté.

Vibia Lighting, S.L.U.

Spain & Portugal T. +34 934 796 970

International T. +34 934 796 971

customer.service@vibia.com

www.vibia.com

VIBIA